

SPEEFLO LIMITED WARRANTY

Speeflo Manufacturing Corporation warrants all equipment manufactured by it and bearing its brand names to be free from defects in material and workmanship at the time of sale by an authorized Speeflo distributor. Speeflo will for a period of twelve months (twenty-four months on selected air powered models) from the date of sale, repair or replace any part of the equipment proven defective. Repair or replacement under this warranty shall be purchaser's sole remedy for breach of this warranty. Products furnished by but not manufactured by Speeflo (such as hose, motors, engines, hydraulic pumps, etc.) will carry only the warranty of the manufacturer, if any. Speeflo does not warranty and disclaims all implied warranties of merchantability and fitness for a particular purpose for accessories, materials, equipment, components and products not made by Speeflo.

This warranty shall not apply if the product has been subject to misuse, negligence, accident or tampering or has not been operated or installed in accordance with Speeflo's recommendations. This warranty does not cover and Speeflo shall not be liable for any damage, wear or malfunction caused by improper or inadequate maintenance, abrasion, corrosion or substitution of components, parts or hydraulic fluid not supplied by Speeflo. Speeflo shall not be liable for the improper design, manufacture, installation, operation or maintenance of accessories, components or materials not supplied by Speeflo. Speeflo shall not be liable for damage or wear caused by incompatibility with Speeflo equipment of materials, equipment or accessories not supplied by Speeflo.

This warranty applies only to the original purchaser and only when the equipment is installed, operated and maintained in accordance with Speeflo's written recommendations or instructions. Purchaser must, with transportation prepaid, return the equipment claimed to be defective to Speeflo or to an authorized Warranty Service Center for verification of the claimed defect. If the alleged defect is verified, Speeflo will, at Speeflo's option, repair or replace any defective parts. The equipment will be returned including prepayment of transportation charges to the original purchaser. If no defects in material and workmanship are found, repairs will be made by Speeflo at a reasonable charge. Charges may include the cost of parts, labor and freight.

No statement or recommendation made or assistance given by Speeflo or its representatives to purchaser, lessee or user or its representatives shall constitute a warranty by Speeflo or a waiver or modification of any of the provisions hereof to create any liability for Speeflo. No sample or model shall create an express warranty that the products shall conform to any sample or model exhibited by Speeflo.

SPEEFLO DISCLAIMS TO THE FULL EXTENT PERMITTED BY LAW ALL WARRANTIES, EXPRESSED OR IMPLIED, INCLUDING ANY WARRANTY OF MERCHANTABILITY OR WARRANTY OF FITNESS FOR A PARTICULAR PURPOSE AND ANY NON CONTRACTUAL LIABILITIES INCLUDING PRODUCT LIABILITY BASED ON NEGLIGENCE OR STRICT LIABILITIES. Every form of liability is expressly excluded and denied for direct, indirect, special or consequential damages or loss. This warranty shall be in lieu of any other warranty expressed or implied. The terms of this warranty constitute purchaser's sole and exclusive remedy. In no case shall Speeflo's liability exceed the amount of the purchase price. Any action for breach of warranty must be brought within two (2) years of the date of sale.

Speeflo Manufacturing Corporation
P. O. Box 111249 - Houston, TX 77293-0249

1995 Speeflo Manufacturing Corporation
All rights reserved

**OPERATOR'S MANUAL
FOR ALL HYDRA M™
& HYDRA PRO SUPER™
HONDA POWERED AIRLESS SPRAYERS**

MODEL NUMBERS
HYDRA M 2000™
433-860
433-861

MODEL NUMBERS
HYDRA M 4000™
433-800
433-801
433-802

**HYDRA PRO
SUPER™**
433-810

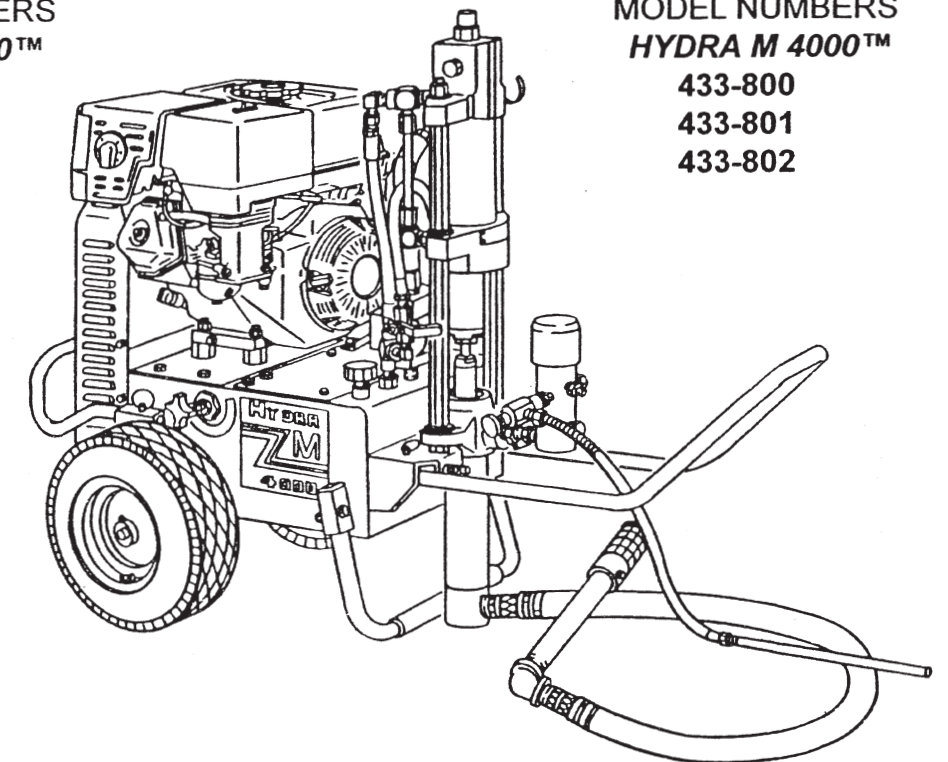

! WARNING !

**HIGH PRESSURE DEVICE
FOR PROFESSIONAL USE ONLY.
READ AND UNDERSTAND THIS MANUAL BEFORE USE.
KEEP THIS MANUAL FOR REFERENCE.**

SPEEFLO MANUFACTURING CORPORATION
P. O. BOX 111249 - HOUSTON, TX 77293
© 1995 Speeflo Manufacturing Corp. All Rights Reserved



When reliability counts

Congratulations on having selected the finest airless sprayer available in the world. *Speeflo* piston pumps are tireless workhorses - so tough they are virtually indestructible, even under the most severe service. *Speeflo* designs and builds equipment with superior quality and reliability. Equipment that will last for years with minimal maintenance and downtime. This equipment will make you money year after year. We thank you for your purchase and welcome you to our large and growing family of *Speeflo* users.

Hydraulic drive makes possible the longest stroke and slowest cycling pumps in the industry which translates into low maintenance and longer life.

The *HYDRA M 2000 and 4000*™ offer other cost saving features:

- . Variable Pressure Control
- . Very Large Tungsten Carbide Valve Seats with Hardened Stainless Steel Balls
- . Self-Adjusting Packings
- . Exclusive Hand-Tight Swivel Foot Valve
- . Large Capacity Inline Paint Filter
- . "Floating Ball" Pressure Bleed Valve
- . 5 Gallon Siphon Hose and Bleed Line Assemblies are standard.

You have made an excellent choice. We know you will be pleased with your new *HYDRA M*™ airless sprayer. We appreciate your business.



WARNING: The Engine Exhaust from this product contains chemicals known to the State of California to cause cancer, birth defects or other reproductive harm.

KEY ACCESSORIES AND SERVICE KITS

These items may be purchased separately from your local SPEEFLO distributor.

PART NO	DESCRIPTION
103-818	Siphon Hose Assembly with CamLock Assembly, 1 1/2" x 6'
103-807	Siphon Hose Assembly with Rock Catcher, 1" x 4'
103-812	Siphon Hose with Rock Catcher 1 1/4" x 4'
103-629	Rock Catcher
920-001	Paint Filter Element, 5 Mesh (for multicolors and heavy materials)
920-004	Paint Filter Element, 50 Mesh (for latex and normal architectural materials)
920-005	Paint Filter Elements, 100 Mesh (for stains, lacquers and fine finish materials)
711-002	Gun and Hose Kit - For Architectural Coatings -(includes 520-100 SGX-20 Gun with 641-517 SC-5™ Reversible Tip, .017 x 50° and 250-514 Airless Hose Assembly 1/4" x 50', 3300 psi)
711-003	Gun and Hose Kit - For Heavy Materials - (includes 801-309 Heavy Material H-Gun w/Swivel, 250-138 3/8" X 50' 3500 psi Airless Hose Assembly, 641-700 SC-5™ Reversible Tip Base and 641-621 SC-5™ Reversible Tip, .021 x 60°)
711-004	Gun and Hose Kit - For Heavy Materials - (includes 801-309 Heavy Material H-Gun w/Swivel, 250-538 3/8" X 50' 5000 psi Airless Hose Assembly, 641-700 SC-5™ Reversible Tip Base and 641-621 SC-5™ Reversible Tip, .021 x 60°)
160-124	Nylon Paint Strainer - 1 Gallon (Pack of 24)
160-524	Nylon Paint Strainer - 5 Gallon (Pack of 24)
101-208	Grounding Clamp
101-212	Grounding Wire, 12 Gauge x 25'
310-203	Lubrisolv™ Upper Packing Lubricant, 8 Ounces
430-362	Coolflo™ Hydraulic Fluid, 1 Quart
430-361	Coolflo™ Hydraulic Fluid, 1 Gallon
441-071	Minor Service Kit for Hydraulic Motor
441-701	Major Service Kit of Hydraulic Motor
185-050	Minor Service Kit for 185-551 Fluid Pump
185-500	Major Service Kit for 185-551 Fluid Pump
245-050	Minor Service Kit for 245-555 Fluid Pump
245-500	Major Service Kit for 245-555 Fluid Pump
315-050	Minor Service Kit for 315-555 Fluid Pump
315-500	Major Service Kit for 315-555 Fluid Pump
920-050	Service Kit for Paint Filter
944-050	Service Kit for Bleed Valve
975-102	2-Gun Manifold with Ball Valves, 1/4"
975-104	4-Gun Manifold with Ball Valves, 1/4"
975-111	1-Gun Add-On, 1/4"
975-302	2-Gun Manifold with Ball Valves, 3/8"
975-304	4-Gun Manifold with Ball Valves, 3/8"
975-311	1-Gun Add-On, 3/8"

**HYDRA M™ & HYDRA PRO SUPER™
OUTLET ACCESSORIES
GUN MANIFOLD ASSEMBLIES**

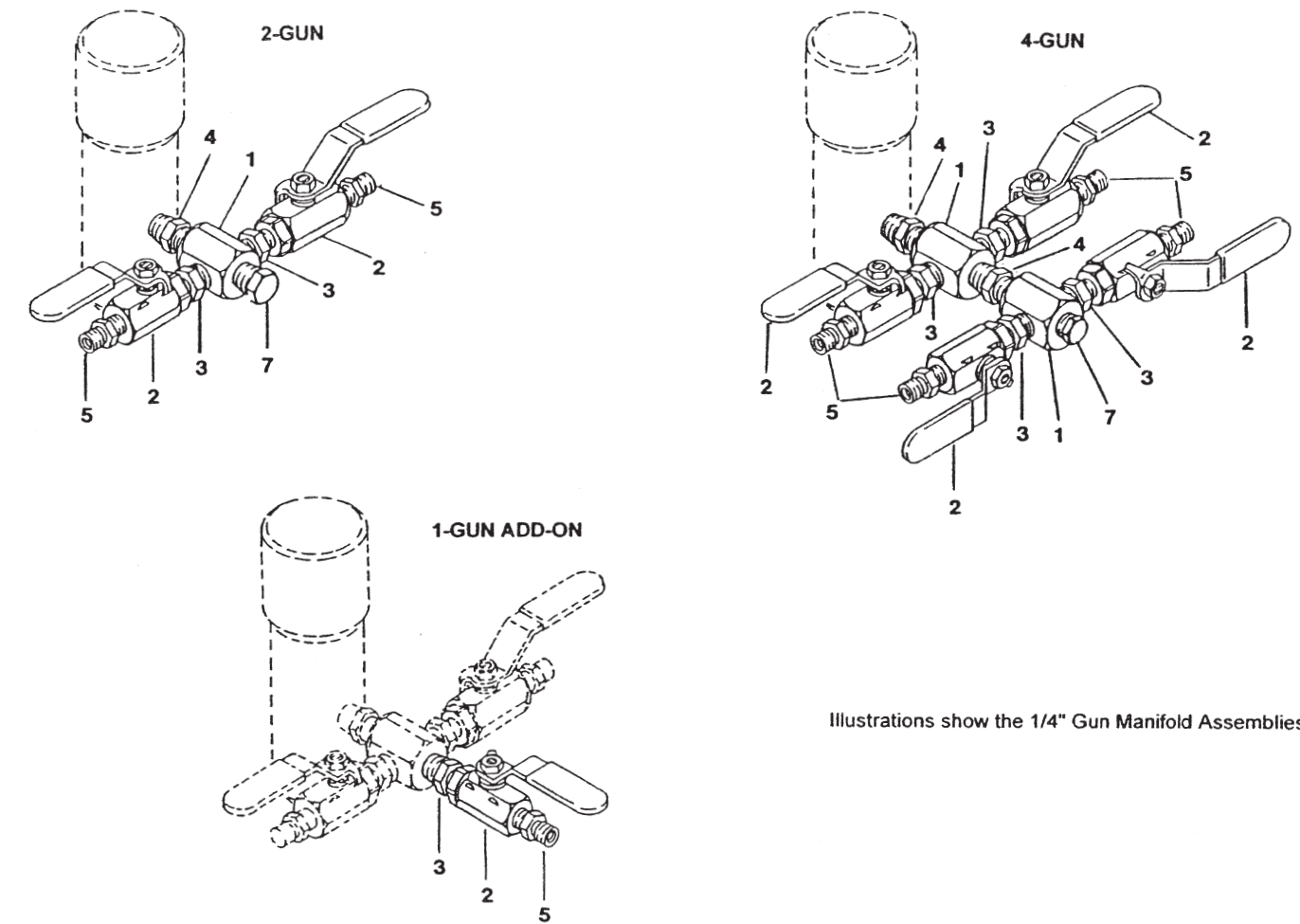

Illustrations show the 1/4" Gun Manifold Assemblies

SPECIFICATIONS			
	HYDRA M 4000™	HYDRA M 2000™	HYDRA PRO SUPER™
Delivery (GPM)	3.3	6.0	2.5
Cycle Rate (Gallon)	13	7	24
Cycles per Minute (Maximum)	43	42	60
Maximum Tip Size - 1 Gun	.055"	.072"	.049"
Maximum Tip Size - 2 Guns	.037"	.052"	.033"
Maximum Tip Size - 3 Guns	.031"		.027"
Pressure Range (psi)	500 - 4000	500 - 2000	500 - 4500
Power	13 HP Honda Engine, electric start		
Fuel Capacity	1.85 Gallons		
Halogenated Solvent Compatible	Yes		
Weight	361	421	354
Inlet Paint Filter	1 1/4" Rock Catcher	N/A	1" Rock Catcher
Outlet Paint Filter	50 Mesh, 18 in. ²	N/A	50 Mesh, 18 in. ²
Pump Inlet	1 1/4"	1 1/2"	1"
Pump Outlet	1/2" NPT(F)	1" NPT(F)	1/2" NPT(F)
Paint Filter Hose Connections	(1) - 1/4" NPSM(M) (1) - 3/8" NPT(F) Plugged	N/A	(1) - 1/4" NPSM(M) (1) - 3/8" NPT(F) Plugged
Dimensions	38" H x 52" L w/Handle (32" L w/o Handle) x 24-1/2" W	40" H x 52" L w/Handle (32" w/o Handle) x 24-1/2" W	38" H x 52" L w/Handle (32" L w/o Handle) x 24-1/2" W
Fluid Pump Wetted Parts	Electroless nickel plated ductile iron, electroless nickel plated carbon steel, proprietary hard chrome anti-wear surface, stainless steel, tungsten carbide, Teflon, thiokol impregnated leather, ultra high molecular weight polyethylene.		

GUN MANIFOLD ASSEMBLIES								
ITEM NO.	PART NO.	DESCRIPTION	975-102	975-104	975-111	975-302	975-304	975-311
			2 - GUN 1/4"	4 - GUN 1/4"	1 - GUN ADD-ON 1/4"	2 - GUN 3/8"	4 - GUN 3/8"	1 - GUN ADD-ON 3/8"
1	970-100	Manifold	1	2		1	2	
2	940-553	Valve, Ball	2	4	1			
2a	941-555	Valve, Ball				2	4	1
3	814-002	Nipple, Hex	2	4	1			
4	814-004	Nipple, Hex	1	2		3	6	1
5	227-006	Nipple, Hex	2	4	1			
6	808-555	Nipple, Hex				2	4	1
7	227-033	Plug, Pipe	1	1		1	1	

**HYDRA M™ & HYDRA PRO SUPER™
OUTLET ACCESSORIES**

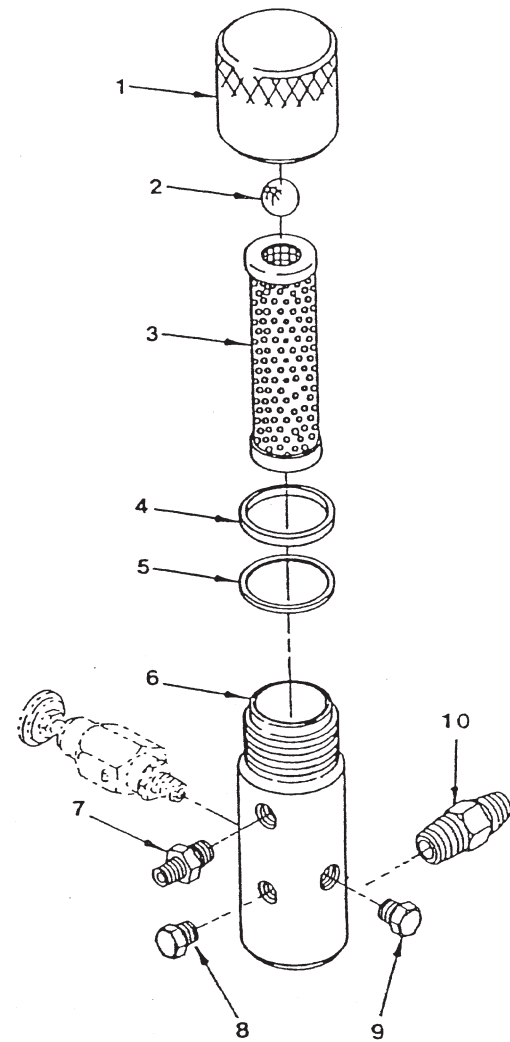

CLEANING

Clean filter regularly. Dirty or clogged filters can greatly reduce filtering ability and cause a number of system problems including poor spray patterns, clogged spray tips, etc.

To clean the filter, shutoff system and relieve all system pressure. See the Pressure Relief Procedure on Page 12.

Remove filter cap (1). Pull filter element with check ball (3) straight out of filter body (6). Thoroughly clean inside filter body (6) filter element with check ball (3) and filter cap (1) with appropriate solvent. Use care in handling parts as dirt, debris, scratches or nicks may prevent "O" Rings or gaskets from sealing. The 920 Series Filter Elements filter from the inside out. Be certain to clean the screen element thoroughly on the inside. Soak in solvent to loosen hardened paint. etc. or replace.

OUTLET MANIFOLD FILTER ASSEMBLY PART NO. 920-559			
ITEM NO.	PART NO.	DESCRIPTION	QTY.
1	920-917	Filter Cap Assembly	1
2	920-103	Ball	1
3	920-004	Filter Element, 50 M	1
4	920-006	Gasket, Teflon, (Thick)	1
5	920-070	Gasket, Teflon, (Thin)	1
6	920-927	Filter Body	1
7	812-003	Nipple, Hex	1
8	227-027	Plug, Pipe	1
9	227-033	Plug, Pipe	1
10	191-449	Nipple, Hex	1

FILTER SERVICE KIT PART NO. 920-050			
ITEM NO.	PART NO.	DESCRIPTION	QTY.
2	920-103	Ball	1
4	920-006	Gasket, Teflon	1
5	920-070	Gasket, Teflon	1

SPECIFICATIONS	
Maximum Working Pressure	5000 psi (345 bar)
Filter Area	18 In ² (116 cm ²)
Outlet Ports	(1) 1/4" NPT (F) for bleed valve (1) 3/8" NPT(F) with 1/4 NPSM(M) hose connection (1) 3/8" NPT(F) plugges for additional gun hookup.
Wetted Parts	Carbon steel with electroless nickel and cadmium plating, stainless steel, Teflon

SAFETY WARNINGS

! WARNING !

**HIGH PRESSURE DEVICE · FOR PROFESSIONAL USE ONLY
READ AND UNDERSTAND ALL LABELS AND OPERATOR'S MANUALS BEFORE USE.
OBSERVE ALL WARNINGS.**

INJECTION HAZARD



High pressure application equipment can cause serious injury if liquid penetrates the skin. DO NOT point any high pressure device -- gun or nozzle -- at anyone or any part of the body. Avoid accidental triggering of gun by always setting safety latch when not spraying. Never spray without a tip guard. Do not attempt to deflect or stop leaks in the system with any part of the body. In case of accidental skin injection, seek immediate emergency medical treatment. Failure to follow this warning can result in amputation or serious injury.

COMPONENT RUPTURE

The system is capable of producing high pressure. To avoid component rupture or personal injury, all components in system must have a maximum rated working pressure not less than the pressure stated on the pump.

FIRE AND EXPLOSION HAZARD



Spray painting, flushing or cleaning equipment with flammable liquids in confined areas can result in fire or explosion. Use outdoors or in extremely well ventilated areas.

High velocity flow of material may create static electricity. Ground equipment, hoses, containers, and objects being sprayed to prevent sparking, which may cause fire or explosion.

Avoid all ignition sources such as static electricity from plastic drop cloths, open flames such as pilot lights, hot objects such as cigarettes, arcs from connecting or disconnecting power cords or turning light switches on and off.

Failure to follow this warning can result in death or serious injury.

SERVICING

Before cleaning, servicing, or removing any component of the system, always shut off power source, carefully release fluid pressure in the system and set safety lock on guns and equipment.

SAFETY WARNING

! PELIGROSO !

DISPOSITIVO DE ALTA PRESION. PARA USO PROFESIONAL UNICAMENTE. ANTES DE UTILIZARLO, LEA Y ENTIENDA TODAS LAS ETIQUETAS Y MANUALES DEL OPERADOR. OBSERVE TODAS LAS PRECAUCIONES.

RIESGOS DE INYECCION



El equipo de aplicación de alta presión puede causar daño muy serio si el líquido penetra la piel. **NUNCA** apunte ningún dispositivo de alta presión (boquilla o pistola) a persona alguna ni a cualquier parte del cuerpo. Evite que se dispare la pistola accidentalmente colocándole, siempre, el pasador de seguridad cuando no esté en uso. Nunca rocíe sin un protector de boquilla. No intente corregir o detener las fugas en el sistema con ninguna parte del cuerpo. En caso de inyección accidental de la piel, busque tratamiento médico inmediatamente. Dejar de seguir estas advertencias puede resultar en amputación o daño muy serio.

RUPTURA DE LOS COMPONENTES

Este sistema es capaz de producir altas presiones. Para evitar la rotura de los componentes o daño personal, todos los componentes en el sistema deben tener una presión de trabajo máxima no menor que la presión indicada en la bomba.

RIESGO DE EXPLOSION Y FUEGO



Pintar, lavar o limpiar equipo con líquidos inflamables en áreas encerradas pueda provocar fuego o explosión. Utilícese al aire libre o en áreas extremadamente bien ventiladas.

El flujo de material a velocidades altas puede producir electricidad estática. Ponga a tierra todo el equipo, mangueras, recipientes y los objetos que se estén rociando para evitar chispas que puedan provocar fuego o explosión.

Evite todas las fuentes de ignición tales como electricidad estática de las telas plásticas para cubrir, llamas encendidas tales como pilotos, objetos calientes tales como cigarrillos, arco eléctrico al conectar o desconectar cables eléctricos o encender y apagar los interruptores de luz.

El dejar de seguir estas advertencias puede provocar daños muy severos o la muerte.

SERVICIO

Antes de limpiar, dar servicio o remover cualquier componente del sistema, siempre desconecte la fuente de potencia, libere cuidadosamente la presión del fluido en el sistema y coloque el seguro de las pistolas y equipo.

HYDRA M™ & HYDRA PRO SUPER™ FLUID ACCESSORIES

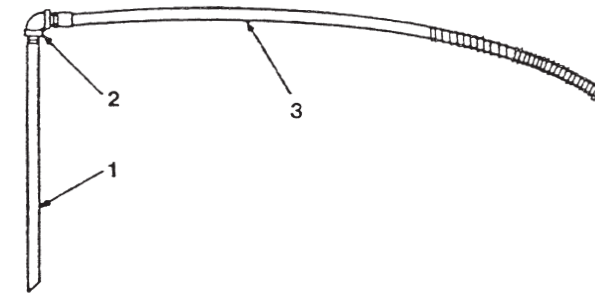

BLEED LINE ASSEMBLY PART NO. 103-106			
ITEM NO.	PART NO.	DESCRIPTION	QTY.
1	103-317	Tube	1
2	201-555	Elbow	1
3	538-031	Hose Assembly	1

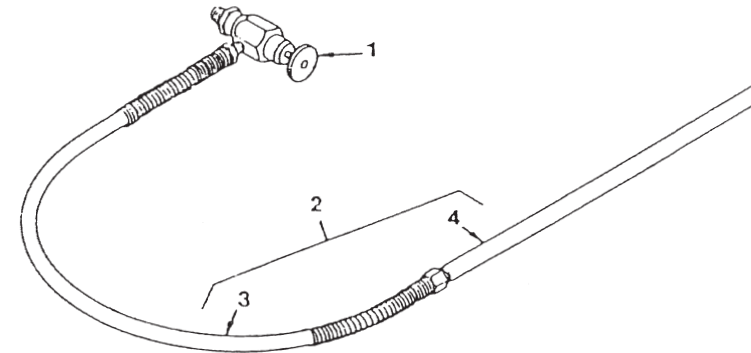

BLEED LINE ASSEMBLY WITH VALVE PART NO. 840-209			
ITEM NO.	PART NO.	DESCRIPTION	QTY.
1	944-620	Valve	1
2	103-101	Bleed Line Assembly	1
3	538-030	Hose Assembly (1)	
4	103-117	Tube (1)	

SERVICE INSTRUCTIONS

The 944 / 945 Series Relief Valve has a Tungsten Carbide Seat (9) and should not require frequent replacement. The Tungsten Carbide Ball (7), in normal service, will last a long time because it rotates and wears evenly. If there is leakage, replace the ball. **CAUTION:** Open the Adjustment Knob (1), to full counterclockwise position before unthreading Valve Seat (9), from Valve Body (4). If the Valve Stem (3) is rotated inwardly with the ball removed, the Teflon "O" Ring (5), may require replacement. If there has been leakage from the valve stem, the teflon "O" ring should be replaced. **IMPORTANT:** The Valve Stem Stop (6), must be unthreaded from the Valve Stem (3), with a socket screwdriver, then the valve stem can be threaded out of the valve body. **CAUTION:** All non-moving threads must be assembled with Loctite Sealant, *Speeflo Part # 426-051*.

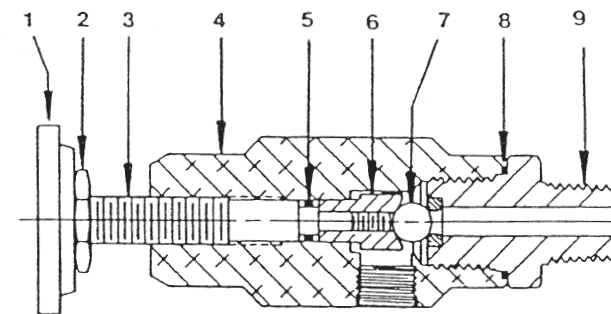

PART # 944-600

944-620 BLEED VALVE ASSEMBLY, 1/8" NPT			
ITEM NO.	PART NO.	DESCRIPTION	QTY.
1	944-005	Knob	1
2	860-721	Nut	1
3	944-023	Stem, Valve	1
4	944-020	Body, Valve	1
5	944-004	"O" Ring, Teflon	1
6	944-026	Stop, Valve Stem	1
7	569-170	Ball	1
8	945-003	Gasket, Copper	1
9	944-904	Seat, Valve	1

945-600 BLEED VALVE ASSEMBLY, 1/2" NPT			
ITEM NO.	PART NO.	DESCRIPTION	QTY.
1	945-005	Knob	1
2	970-011	Nut	1
3	945-023	Stem, Valve	1
4	945-022	Body, Valve	1
5	891-073	"O" Ring, Teflon	1
6	945-026	Stop, Valve Stem	1
7	138-226	Ball	1
8	891-183	"O" Ring, Teflon	1
9	945-906	Seat, Valve	1

**HYDRA M™ & HYDRA PRO SUPER™
FLUID ACCESSORIES**

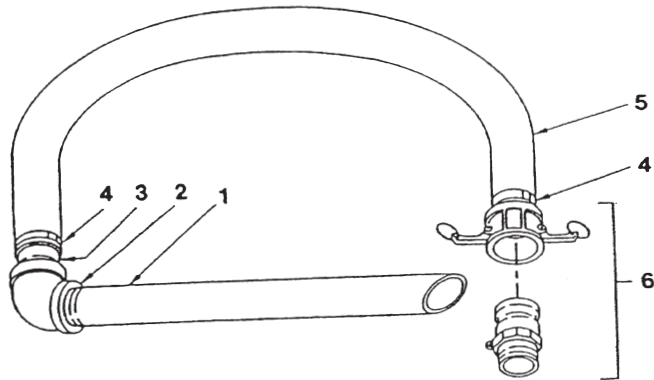

SIPHON HOSE ASSEMBLY PART NO. 103-818			
ITEM NO.	PART NO.	DESCRIPTION	QTY.
1	103-612	Tube	1
2	192-991	Elbow	1
3	194-991	Nipple	1
4	103-684	Clamp	2
5	421-202	Hose	1
6	194-201	CamLock Assembly	1

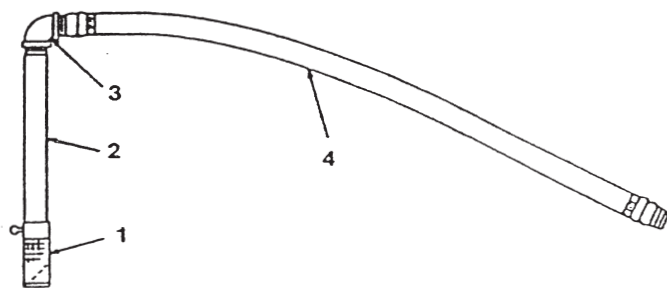

SIPHON HOSE ASSEMBLY PART NO. 103-812			
ITEM NO.	PART NO.	DESCRIPTION	QTY.
1	103-629	Rock Catcher Assembly	1
2	103-641	Tube	1
3	205-559	Elbow	1
4	604-125	Hose Assembly	1

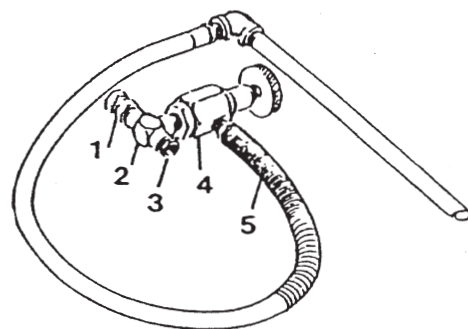

OUTLET ASSEMBLIES WITH PRESSURE BLEED VALVE				
ITEM NO.	PART NO.	DESCRIPTION	840-207	840-208
1	200-556	Swivel Adaptor, 1"	1	
1a	138-037	Swivel Adaptor, 3/4"		1
2	813-009	Cross	1	
2a	817-004	Tee		1
3	929-063	Bushing		1
3a	929-075	Bushing	1	
3b	929-076	Bushing	1	
4	945-600	Valve, Bleed	1	1
5	103-106	Bleed Line Assembly	1	1
6	210-039	Plug, Pipe	1	

SAFETY WARNINGS

INJECTION HAZARDS

Any injury caused by high pressure liquid can be serious. If you are injured or even suspect an injury:

- Go to an emergency room now.
- Tell the doctor you suspect an injection injury.
- Show the doctor the "Note to Physician" below.
- Tell the doctor the kind of material you were spraying.

NOTE TO PHYSICIAN

Injection in the skin is a serious traumatic injury. *IT IS IMPORTANT TO TREAT THE INJURY SURGICALLY AS SOON AS POSSIBLE.* Do not delay treatment to research toxicity. Toxicity is a concern with some exotic coatings injected directly into the bloodstream. Consultation with a plastic surgeon or reconstructive surgeon may be advisable.

The seriousness of the wound depends on where the injury is on the body, whether the substance hit something on its way in and deflected causing more damage, and many other variables including skin microflora residing in the paint or gun which are blasted into the wound. If the injected paint contains acrylic latex and titanium dioxide that damage the tissue's resistance to infection, bacterial growth will flourish. The treatment that doctors recommend for an injection injury to the hand includes immediate decompression of the closed vascular compartments or the hand to release the underlying tissue distended by the injected paint, judicious wound debridement, and immediate antibiotic treatment.

SPRAY GUN SAFETY

Airless sprayers develop extremely high pressures. Therefore **NEVER** put your hand or fingers in front of the spray gun and **NEVER** point the gun at your body or anyone else. Always relieve system pressure and use extreme caution when removing or cleaning spray tips.

Any time you are not spraying, always set the gun safety latch in the "closed" or "safe" position. This will prevent accidental triggering. Always use the spray gun with the safety tip guard.

PRESSURE RELIEF

Before checking or servicing any part of the spray system, including cleaning or changing spray tips, or

when sprayer is to be left unattended, always relieve system pressure. Follow the procedure on Page 12.

MOVING PARTS HAZARDS

Moving parts can pinch or amputate your fingers or other parts of your body. Keep clear of moving parts when starting or operating the sprayer. **NEVER** operate sprayer with belt guard removed. Relieve system pressure before checking or servicing any component of system.

EQUIPMENT MISUSE

1. All chemicals or coatings used with this sprayer must be chemically compatible with the wetted parts shown in the Technical Data. Consult with the material manufacturer for fluid compatibility.
2. These sprayers can develop up to 4000 psi maximum working pressure. Be sure that any accessories added to this system are rated for the proper working pressure.
3. **NEVER** alter or modify any part of this system. To do so could cause a malfunction resulting in serious injury.
4. Check equipment regularly for worn or damaged components (i.e. hoses). Replace these worn or damaged components immediately.
5. Always wear protective eyewear, protective clothing and respirator as recommended by the coating and solvent manufacturer.
6. This equipment is a professional application device. It is not a toy; do not use it in a careless manner. Keep children and pets away.

GASOLINE ENGINE SAFETY

1. Honda engines are designed to give safe and dependable service if operated according to instructions. Read and understand the Honda Owner's Manual before operating the engine. Failure to do so could result in personal injury or equipment damage.
2. To prevent fire hazards and to provide adequate ventilation, keep the engine at least 1 meter (3 feet) away from buildings and other equipment during operation. Do not place flammable objects close to the engine.

SAFETY WARNINGS

3. Children and pets must be kept away from the area of operation due to a possibility of burns from hot engine components or injury from any equipment the engine may be used to operate.
4. Know how to stop the engine quickly, and understand the operation of all controls. Never permit anyone to operate the engine without proper instructions.
5. Gasoline is extremely flammable and is explosive under certain conditions.
6. Refuel in a well-ventilated area with the engine stopped. Do not smoke or allow flames or sparks in the refueling area or where gasoline is stored.
7. Do not overfill the fuel tank. After refueling, make sure the tank cap is closed properly and securely.
8. Be careful not to spill fuel when refueling. Fuel vapor or spilled fuel may ignite. If any fuel is spilled, make sure the area is dry before starting the engine.
9. Never run the engine in an enclosed or confined area. Exhaust contains poisonous carbon monoxide gas; exposure may cause loss of consciousness and may lead to death.
10. The muffler becomes very hot during operation and remains hot for a while after stopping the engine. Be careful not to touch the muffler while it is hot. To avoid severe burns or fire hazards, let the engine cool before transporting it or storing it indoors.

WARNING LABELS

Your sprayer has the English language Danger Label shown on Page 3 in the location indicated below. If you require this label in French, German, or Spanish, or require additional English labels, order directly from Speeflo free of charge. Call toll free 1-800-231-9929.

PART NO.	LANGUAGE
745-089 745-104	English
745-106 745-107	Spanish
745-108 745-109	French
745-110 745-111	German

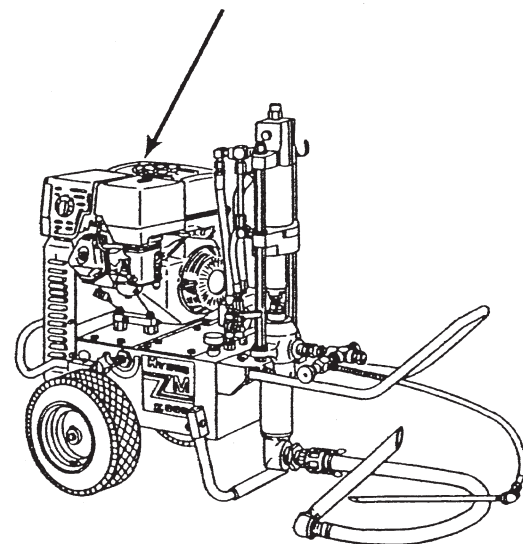

HYDRA PRO SUPER™ 185-551 FLUID PUMP SERVICE KITS

NOTE: Minor Service Kit # 185-050 has polyethylene/leather packings.
Minor Service Kit # 180-051 has leather packings.
Minor Service Kit # 185-052 has Teflon packings.

PUMP SERVICE KITS, MINOR			CTR	IND	TFL
ITEM NO.	PART NO.	DESCRIPTION	185-050	185-051	185-052
4	175-001	Packing Set, Upper		1	
4	178-001	Packing Set, Upper	1		
4	178-320	Packing Set, Upper			1
7	182-007	"O" Ring, Teflon	1	1	1
11	180-002	Packing Set, Lower		1	
11	180-322	Packing Set, Lower			1
11	183-001	Packing Set, Lower	1		
12	920-103	Ball	1	1	1
14	183-230	"O" Ring	1	1	1
15	182-007	"O" Ring, Teflon	1	1	1
17	314-180	Ball	1	1	1
	426-051	Loctite Sealant	1	1	1

PUMP SERVICE KITS, MAJOR					
ITEM NO.	PART NO.	DESCRIPTION	185-500	185-501	185-502
	185-050	Minor Kit	1		
	185-051	Minor Kit		1	
	185-052	Minor Kit			1
2	182-984	Rod, Displacement	1	1	1
6	182-906	Spring, Packing	1	1	1
8	183-930	Cylinder	1	1	1

SPECIFICATIONS

DISPLACEMENT ROD AREA		STROKE LENGTH		DISPLACEMENT VOLUME / STROKE			DISPLACEMENT VOLUME / 40 CYCLES / 80 STROKES				MOTOR	RATIO
IN ²	CM ²	IN	CM	IN ³	CM ³	LITER	IN ³	GAL	CM ³	LITER	441	
1.38	8.90	4	10.16	5.55	90.9	0.091	444	1.92	7272	7.27	SERIES	3 : 1

**HYDRA PRO SUPER™
185-551 FLUID PUMP
SERVICE INFORMATION**

**IMPORTANT: USE OF NON-SPEEFLO
MANUFACTURED SERVICE PARTS
MAY VOID WARRANTY**

The 185 Series Pumps should receive a routine Servicing after approximately 1,000 hours of use or earlier if there is excessive leakage from the top packing, or if pump strokes become faster on one stroke or the other. The use of **Speeflo, Lubrisolv Part # 310-200**, is recommended as an upper packing lubricant. **DO NOT SUBSTITUTE** oil, water or solvent for an upper packing lubricant.

DISASSEMBLY PROCEDURE

1. Test pump before disassembly. Follow test procedure in Troubleshooting Guide - Fluid Section.
2. Remove siphon hose assembly.
3. Remove Stanchion Nuts (19) and Washers (20).
4. Remove set screw between the two flats on the hydraulic motor. Hold the hydraulic motor rod at the wrench flats and unthread coupling nut to separate pump from motor.
5. Remove Roll Pin (1) or Jam Nut on Connecting Rod (22). Remove Connecting Rod (22) from Displacement Rod (2).
6. Unthread and remove Foot Valve (16).
7. Remove Teflon "O" Ring (15), Buna "O" Ring (14), Ball Cage Assembly (18) and Ball (17).
8. Remove Cylinder (8).
9. Remove Displacement Rod (2).
10. Place Piston Seat (13) in a vise and use a wrench on the flats to remove the Displacement Rod (2) from the Piston Seat (13).
11. Remove Lower Packing Set (11), Spring (10), Spring Retainer (9) and Ball (12).
12. Remove Upper Packing Spring (6), Packing Set (4) and "O" Ring (7).

13. Clean and inspect all parts. Inspect Displacement Rod's (2) and Cylinder's (8) hard chrome for grooves, dents or worn areas. Replace if hard chrome is damaged. Inspect valve seats and replace if cracked or worn.

REASSEMBLY PROCEDURE

1. Insert new Upper Packing Set (4) into Pump Block (3). **CAUTION:** Peak of "V" packings most point upwards (Λ).
2. Insert Upper Spring (6); small end of spring must go toward the packing set.
3. Insert Spring Retainer (9).
4. Place new Lower Packing Set (11) over Piston Seat (13). **CAUTION:** Peak of "V" must point downward (V) on reassembly.
5. Replace Spring (10), Spring Retainer (9), and new Ball (12) on Piston Seat (13).
6. Thread Piston Seat (13) back onto Displacement Rod (2). **CAUTION:** Use Loctite on clean threads.
7. Insert Displacement Rod Assembly through Upper Packing Set (4) in Pump Block (3).
8. Place new "O" Ring (7) on end of Cylinder (8) and thread back into Pump Block (3). **CAUTION:** Lubricate all "O" Rings before assembly.
9. Insert new Ball (17), Ball Cage (18) and new Buna "O" Ring (14) into Foot Valve. **NOTE:** Ball Cage Pin (18a) to be in lower position unless pump is to be used for heavy block filler or roofing materials.
10. Place new Teflon "O" Ring (15) on Cylinder (8) and then install Foot Valve Assembly (16). **Note:** It is not necessary to overtighten foot valve and cylinder into pump block. "O" Ring seals perform sealing function without excessive tightening. Full thread engagement is sufficient. The Foot Valve (16) may be rotated back up to 3/4 turn from full engagement for convenient hose position.
11. Insert Connecting Rod (22) through coupling nut and thread Connecting Rod (22) into Displacement Rod (2).
12. Insert roll pin (1) into Connecting Rod (22). For siphon hose attachment, it is **critically important** that the thread of the siphon hose fit snugly into the foot valve with the hose assembly couplings teflon taped and sealed to prevent air inlet leakage.

HYDRA M 2000™

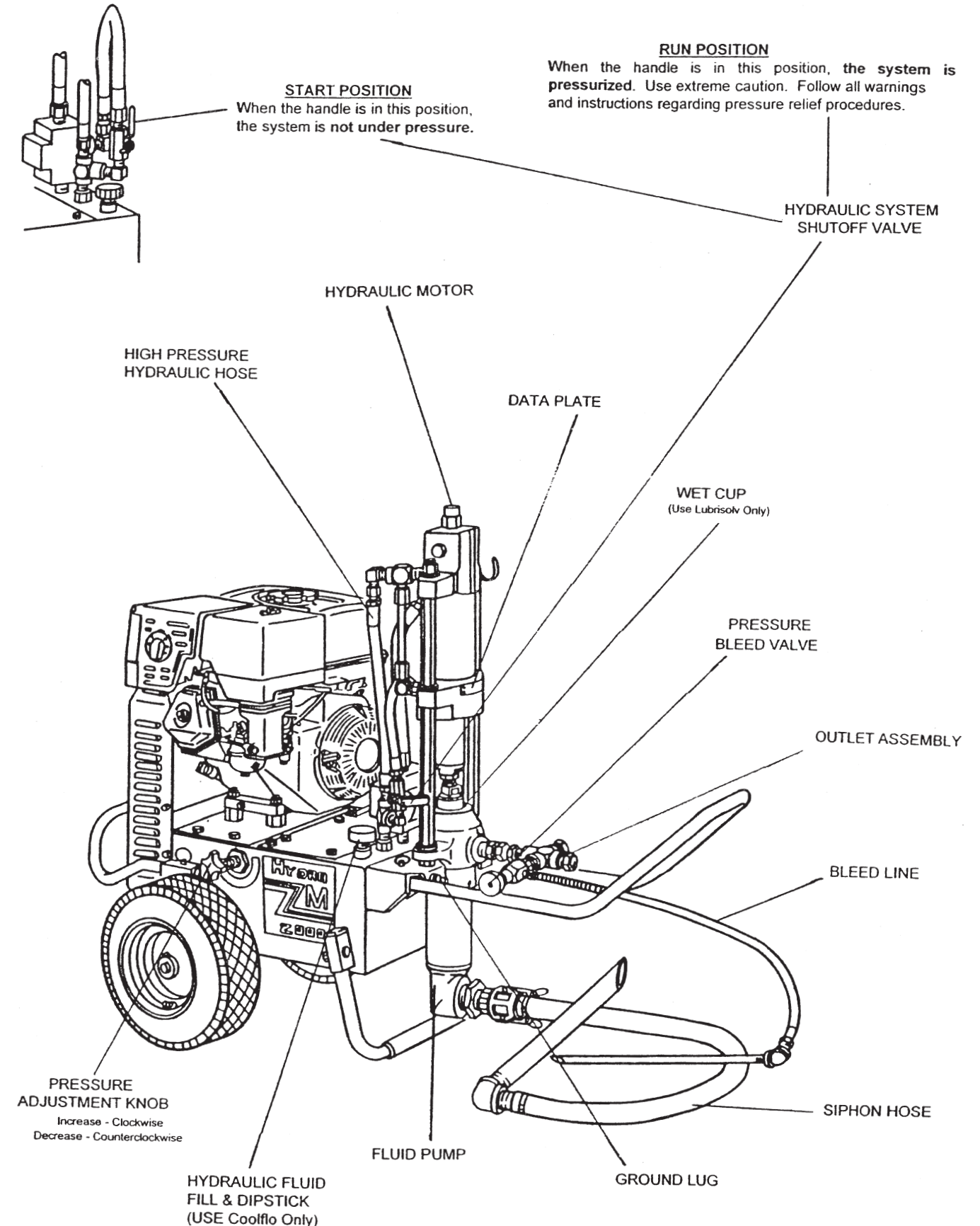

HYDRA M 4000™

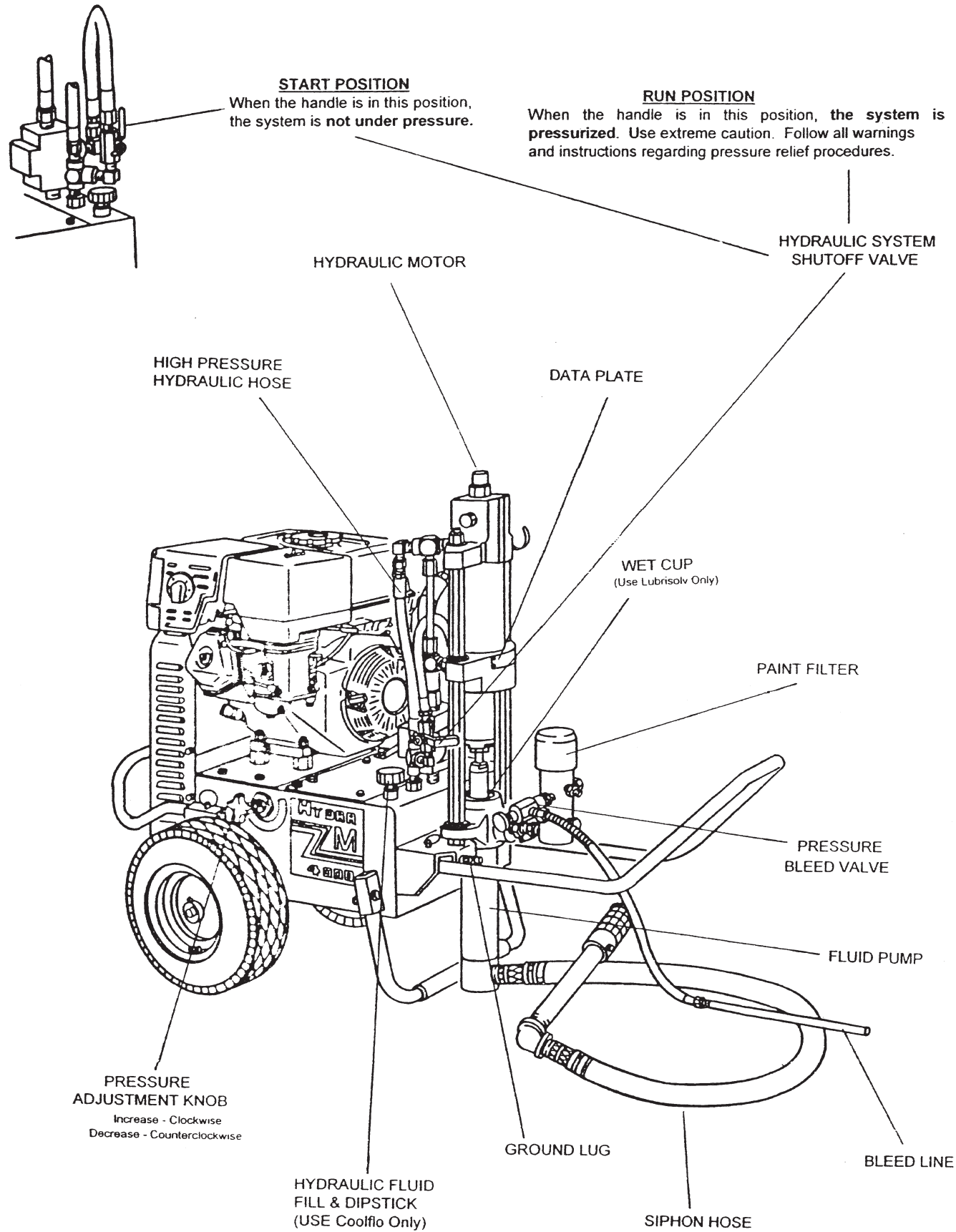

HYDRA PRO SUPER™ 185-551 FLUID PUMP ASSEMBLY

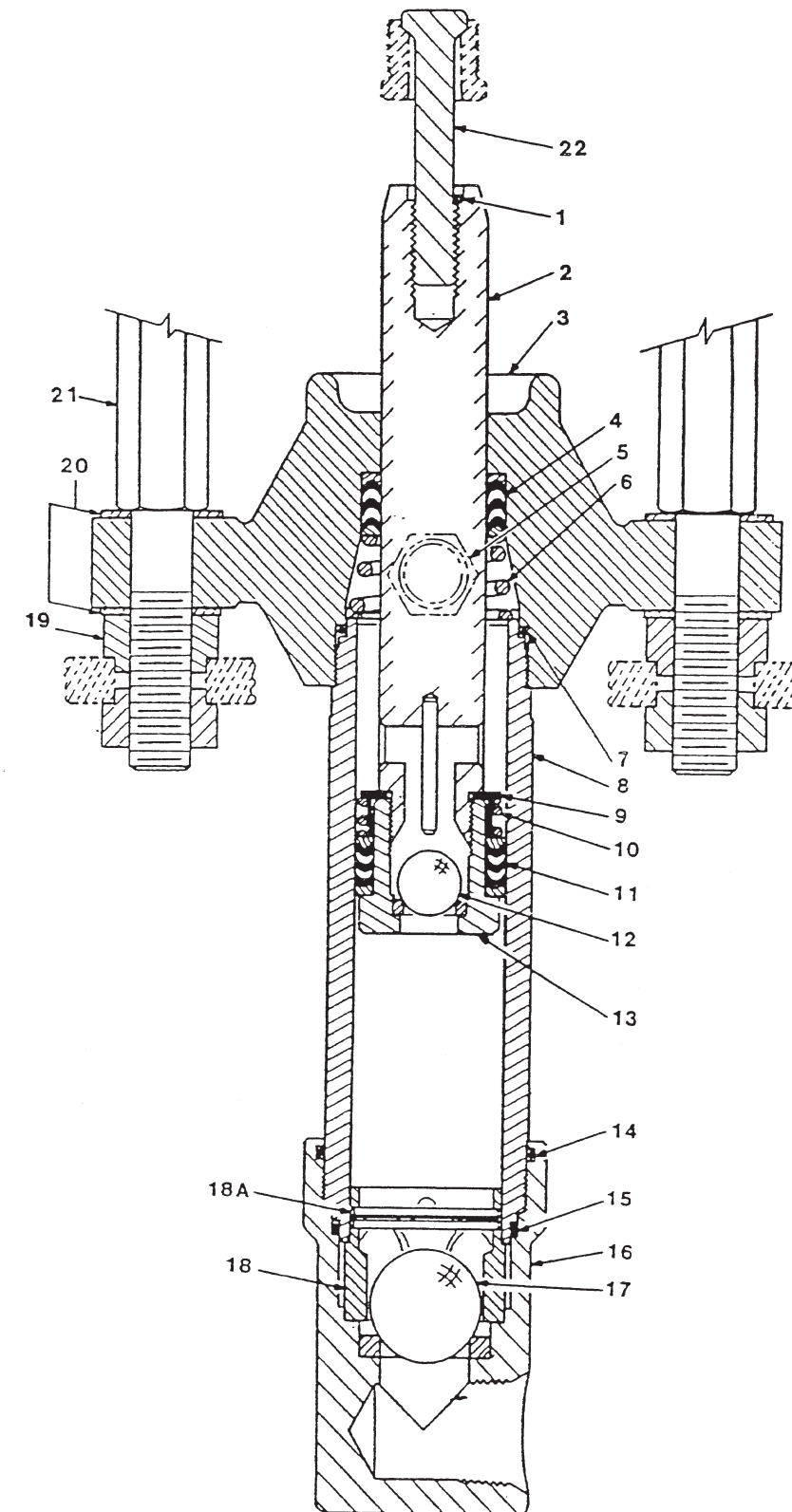

ITEM NO.	PART NO.	DESCRIPTION	QTY.
1	185-981	Pin, Roll	1
2	185-984	Rod, Displacement	1
3	181-906	Block, Pump	1
4	178-001	Packing Set, Upper	1
5	228-002	Nipple, Hex	1
6	182-906	Spring, Packing	1
7	182-007	"O" Ring, Teflon	1
8	183-930	Cylinder	1
9	185-011	Retainer, Spring	1
10	185-010	Spring, Packing	1
11	183-001	Packing Set, Lower	1
12	920-103	Ball	1
13	182-921	Seat, Piston	1
14	183-230	"O" Ring, Buna N	1
15	182-007	"O" Ring, Teflon	1
16	183-992	Valve, Foot	1
17	314-180	Ball	1
18	240-022	Cage, Ball	1
18a	241-109	Pin	1

ASSEMBLY SET - PART NO. 441-101			
ITEM NO.	PART NO.	DESCRIPTION	QTY.
19	870-441	Nut	4
20	870-004	Washer	6
21	441-016	Stanchion	2
22	442-956	Rod, Connecting	1

**HYDRA M 2000™
245-555 FLUID PUMP
SERVICE KITS**

PUMP SERVICE KITS, MINOR					
ITEM NO.	PART NO.	DESCRIPTION	245-050	245-051	245-052
2	240-001	Packing Set, Upper, Poly/Lthr	1		
2	240-101	Packing Set, Upper, Leather		1	
2	240-201	Packing Set, Upper, TFL			1
5	892-323	"O" Ring, Teflon	1	1	1
7	920-103	Ball	1	1	1
10	240-001	Packing Set, Lower, Poly/Lthr	1		
10	240-101	Packing Set, Lower, Leather		1	
10	240-201	Packing Set, Lower, Teflon			1
13	891-403	"O" Ring, Teflon	1	1	1
14	892-281	"O" Ring, Buna	1	1	1
16	314-180	Ball	1	1	1
	426-051	Loctite Sealant	1	1	1

PUMP KITS, MAJOR					
ITEM NO.	PART NO.	DESCRIPTION	245-500	245-501	245-502
	245-050	Minor Kit	1		
	245-051	Minor Kit		1	
	245-052	Minor Kit			1
6	245-012	Cylinder	1	1	1
9	245-014	Spring, Packing	1	1	1
18	245-009	Rod, Displacement	1	1	1

SETUP

WARNING: READ, UNDERSTAND, AND FOLLOW ALL WARNINGS BEFORE STARTING OR OPERATING THIS SPRAYER.

Required tools: Adjustable Wrench

1. Connecting the Hoses:

The siphon hose and the bleed line hose have factory installed Teflon tape on the male end of the hoses. Tighten the siphon hose and bleed line wrench tight. See Figure 1.

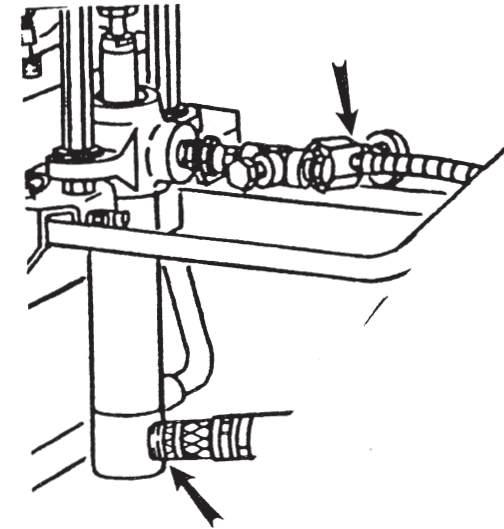

FIGURE 1.

2. One Gun Operation - Attach the gun and hose. Always use a spray hose at least 50 feet long. Do not use Teflon or thread sealant on this assembly. Do not install the spray tip at this time.

3. Two Gun Operation - Remove the plug from the second gun outlet. Replace with nipple, **Part # 812-003**, for 1/4" hose or nipple, **Part # 808-555**, for 3/8" hose. Connect a hose and a gun to the outlet.

4. Multiple Gun Operation - The **HYDRA M 4000™** is engineered to handle up to 4 guns. When using more than two guns, make sure the second gun hookup outlet is plugged. Connect the multiple gun manifold to the single gun outlet. These manifolds are for either 2, 3, or 4 guns and have shut off valves. Connect a hose and gun to each outlet. See Figure 2.

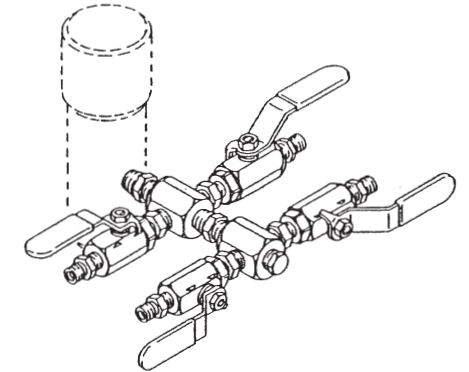

FIGURE 2.

5. Fill the Wet-Cup 1/2 full with **Speeflo's Lubrisolv, Part No. 310-203**, supplied by the factory. This extends packing life.

6. Be sure the **HYDRA M 4000 / 2000™** system is grounded. All Speeflo units are equipped with a grounding lug. A grounding cable (not supplied) should be used to connect the unit to a true earth ground. Check your local electrical regulations for detailed grounding instructions.

----- WARNING -----

Proper grounding is important. This applies to both gas and electric powered models. The passage of some materials through the nylon fluid hose will build up a static electric charge, which if discharged, could ignite solvent vapors present and create an explosion.

7. Strain all paints with **Speeflo # 160-524** 5 gallon Nylon Strainer or **Speeflo # 160-124** 1 gallon Nylon Strainer to assure trouble free operation and freedom from frequent cleaning of inlet screen and gun strainer.

FUELING

WARNING

Gasoline is extremely flammable and is explosive under certain conditions.

1. ALWAYS turn the engine off before refueling.
2. Refuel in a well-ventilated area.
3. Do not smoke or allow flames or sparks in the refueling area or where gasoline is stored.
4. Do not overfill the fuel tank. After refueling, make sure the tank cap is closed properly and securely.
5. Be careful not to spill fuel when refueling. Spilled fuel or fuel vapor may ignite. If any fuel is spilled, make sure the area is dry before starting the engine.
6. Avoid repeated or prolonged contact with skin or breathing of vapor. KEEP OUT OF REACH OF CHILDREN.

Specifications:

Use automotive gasoline that has a pump octane number of 86 or higher.
This engine is certified to operate on unleaded gasoline.
Unleaded fuel produces fewer engine and spark plug deposits and extends the life of exhaust system components.

Never use stale or contaminated gasoline or an oil/gasoline mixture. Avoid getting dirt, dust or water in the fuel tank.

For detailed information refer to the HONDA Engine Owner's Manual.

BATTERY CONNECTIONS

1. Use a 12 volt battery with an ampere-hour rating of at least 18 AH.
2. Connect the battery positive (+) cable to the starter solenoid terminal, as shown.
3. Connect battery negative (-) cable to an engine mounting bolt, frame bolt, or other good engine ground connection.
4. Check the battery cable connections to be sure the cables are tightened and free of corrosion. Remove any corrosion and coat the terminals and cable ends with grease.

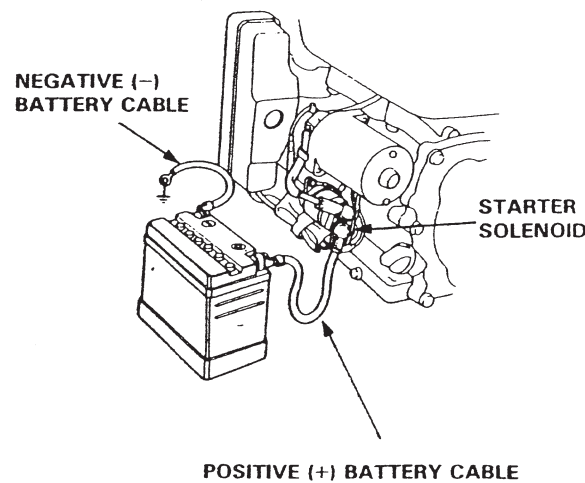

HYDRA M 4000™ 245-555 FLUID PUMP ASSEMBLY SERVICE INSTRUCTIONS

**IMPORTANT: USE OF NON-SPEEFLO
MANUFACTURED SERVICE PARTS
MAY VOID WARRANTY**

The 245 Series Pumps should receive routine servicing after approximately 1,000 hours of use or earlier if there is excessive leakage from the top packing, or if the pump strokes become faster on one stroke or the other. The use of **Speeflo Lubrisolv Part No. 310-200** is recommended as an upper packing lubricant. Do not substitute oil, water, or solvent for an upper packing lubricant.

DISASSEMBLY PROCEDURE

1. Test pump before disassembly. Follow test procedure in Troubleshooting Guide - Fluid Section.
2. Remove siphon hose assembly.
3. Remove Stanchion Nuts (19) and Washers (20).
4. Remove set screw between the two flats on hydraulic motor rod. Hold the hydraulic motor rod at the wrench flats and unthread Coupling Nut (25) to separate pump from hydraulic motor. **CAUTION:** Never use pipe wrench, pliers, etc., on the chrome part of hydraulic or fluid section rod.
5. Remove Roll Pin (23) or Jam Nut on Connecting Rod (24). Remove Connecting Rod (24) from Displacement Rod (18).
6. Unthread and remove Foot Valve (15).
7. Remove Teflon "O" Ring (13), Buna "O" Ring (14), Ball Cage Retainer (17), Ball Cage (12), and Ball (16).
8. Remove Cylinder (6).
9. Remove Displacement Rod (18).
10. Place Piston Seat (11) in a vise and use a wrench on the flats to remove the Displacement Rod (18) from the Piston Seat (11).
11. Remove Lower Packing set (10), Spring (9), Spring Retainer (8) and Ball (7).
12. Remove Upper Spring Retainer (4), Spring (3), Teflon "O" Ring (5) and Packing Set (2).
13. Clean and inspect all parts. Inspect rod's and cylinder's hard chrome for grooves, dents or worn areas. Replace if hard chrome is damaged. Inspect valve seats and replace if cracked or worn.

REASSEMBLY PROCEDURE

1. Insert new Upper Packing Set (2) into Pump Block (1). **CAUTION:** Peak of "V" packings must point upwards (\wedge).
2. Insert Upper Spring (3); small end of spring must go toward the packing set.
3. Insert Upper Spring Retainer (4) and new "O" Ring (5) into Pump Block (1). **Caution:** Lubricate all "O" Rings before reassembly.
4. Place new Lower Packing Set (2) over Piston Seat (11). **CAUTION:** Peak of "V" must point downward (\vee) on reassembly.
5. Replace Spring (9), Spring Retainer (8) and new Ball (7) on Piston Seat (11).
6. Thread seat back onto Displacement Rod (18). **CAUTION:** Use Loctite on clean threads.
7. Insert Displacement Rod assembly through Upper Packing Set (2) in Pump Block (1).
8. Thread Cylinder (6) back into Pump Block (1).
9. Insert new Ball (16), Ball Cage (12), Ball Cage Retainer (17), new Buna "O" Ring (14) and new Teflon "O" Ring (13). **CAUTION:** Lubricate all "O" Rings into Foot Valve (15). **NOTE:** Ball Cage Pin (12a) to be in lower position unless pump is to be used for heavy block filler or roofing materials.
10. Thread Foot Valve (15) back into cylinder (6).
11. Place Connecting Rod (23) through Coupling Nut (24) and thread Connecting Rod (23) into Displacement Rod (18).
12. Replace Roll Pin (23) into Displacement Rod (18).

Note: It is **NOT** necessary to overtighten foot valve and cylinder into pump block. "O" Ring seals perform sealing function without excessive tightening. **Full thread engagement** is sufficient. The Foot Valve (15) may be rotated back up to 1/2 turn from full engagement for convenient hose position.

For siphon hose attachment, it is **critically important** that the threads of the siphon hose fit snugly into the foot valve with the hose assembly couplings Teflon taped and sealed to prevent air inlet leakage.

HYDRA M 4000™
245-555
FLUID PUMP ASSEMBLY

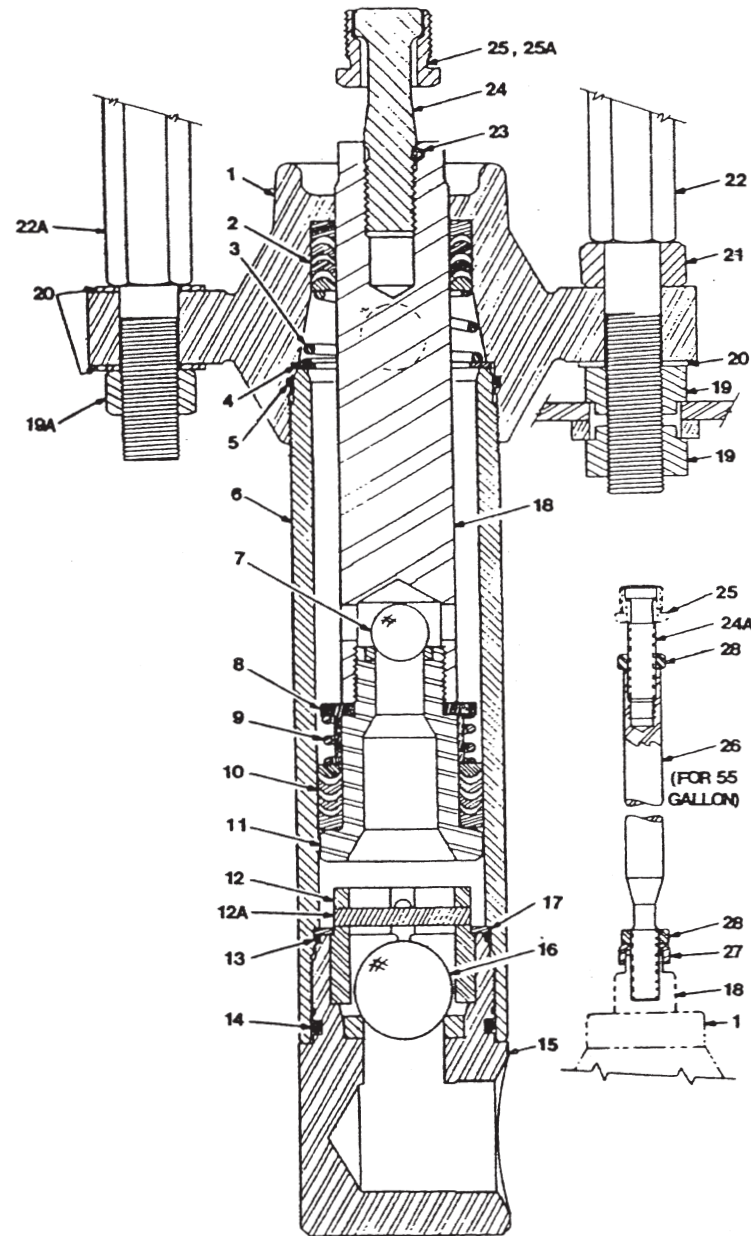

ITEM NO.	PART NO.	DESCRIPTION	QTY.
1	245-907	Block, Pump	1
2	240-001	Packing Set, Poly/Lthr.	1
3	245-005	Packing Spring, Upper	1
4	245-013	Retainer, Spring	1
5	892-323	"O" Ring, Teflon	1
6	245-012	Cylinder	1
7	920-103	Ball, S.S.	1
8	245-020	Retainer, Spring	1
9	245-014	Spring, Packing	1
10	240-001	Packing Set, Poly/Lthr.	1
11	241-007	Seat, Piston	1
12	240-022	Cage, Ball	1
12a	241-109	Pin, Ball Stop (1)	
13	891-403	"O" Ring, Teflon	1
14	892-281	"O" Ring, Buna	1
15	245-018	Valve, Foot	1
16	314-180	Ball, S.S.	1
17	245-021	Retainer, Cage	1
18	245-009	Rod, Displacement	1

ASSEMBLY SETS				
ITEM NO.	PART NO.	DESCRIPTION	STD 441-107	55 GAL 441-108
19	870-441	Nut	4	
19	870-401	Nut		2
20	870-004	Washer	4	6
21	870-006	Spacer	2	
22	140-016	Stanchion	2	
22a	441-010	Stanchion, 55 Gal		2
23	245-109	Roll Pin	1	
24	442-959	Rod, Connecting	1	
24a	441-959	Rod, Connecting		1
25	441-007	Nut, Coupling	*	*
26	180-972	Ext., Connecting Rod		1
27	441-968	Stirrup		1
28	870-021	Nut		1

* Not included in this assembly

BATTERY CONNECTIONS

WARNING

- The battery gives off explosive gases; keep sparks, flames and cigarettes away. Provide adequate ventilation when charging or using batteries in an enclosed space.
- The battery contains sulfuric acid (electrolyte). Contact with skin or eyes may cause severe burns. Wear protective clothing and a face shield.
 - ▲ If electrolyte gets on your skin, flush with water.
 - ▲ If electrolyte gets in your eyes, flush with water for at least 15 minutes and call a physician.
- Electrolyte is poisonous.
 - ▲ If swallowed, drink large quantities of water or milk and follow with milk of magnesia or vegetable oil and call a physician.
- **KEEP OUT OF REACH OF CHILDREN!**

NOTICE:

1. Use only distilled water in the battery. Tap water will shorten the service life of the battery.
2. Filling the battery above the UPPER LEVEL line may cause the electrolyte to overflow, resulting in corrosion to sprayer assembly. Immediately wash off any spilled electrolyte.
3. Be careful not to connect the battery in reverse polarity, as this will short circuit the battery charging system and trip the circuit breaker or fuse.

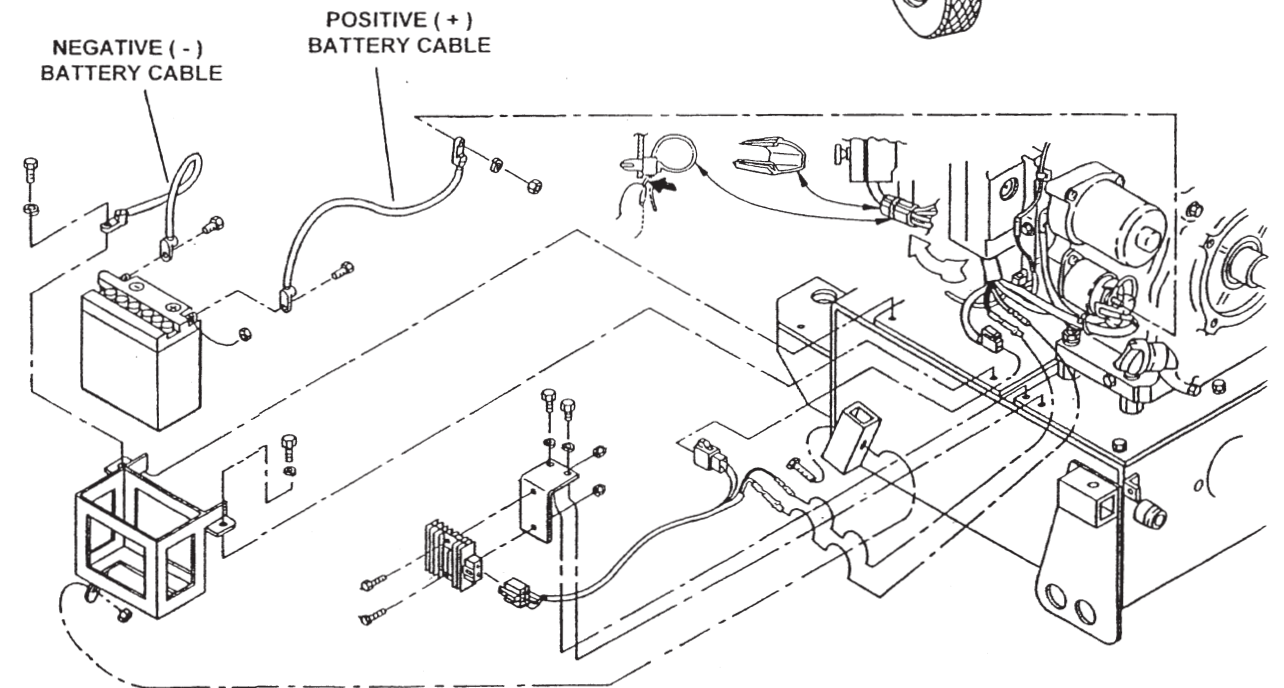
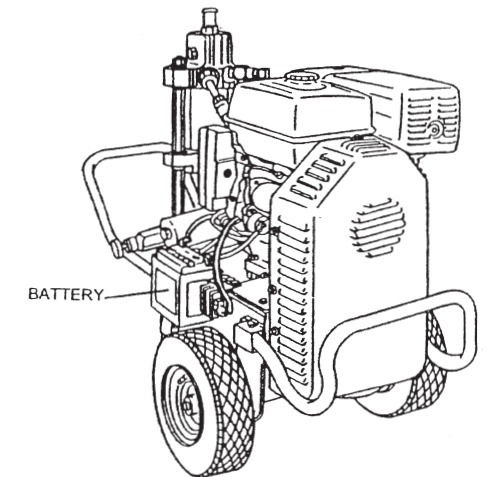

STARTUP

1. Areas must be well ventilated to prevent hazardous operation with volatile solvents or exhaust fumes.

WARNING
If lacquer or other flammable materials are to be sprayed, ALWAYS locate the unit outside the immediate spraying area. Failure to do so may cause an explosion.

2. Locate the unit outside the immediate spraying area to avoid clogged air intake of the engine or electric motor with overspray.
3. **Before starting the unit,** check oil levels.

- A. The hydraulic fluid level should read "Full" on the dipstick. CHECK IT DAILY. See the Hydraulic System Maintenance Instructions for changing or adding hydraulic fluid. Do not overfill. Use only **Speeflo Coolflo™**, Part No. 430-361
- B. The gasoline engine oil level is determined by the manufacturer. Check the manufacturer's service manual supplied.

4. Open the orange handle shut-off valve located on the hydraulic return hose. Handle should be in line with hose. Figure 3 shows the handle in the open position.

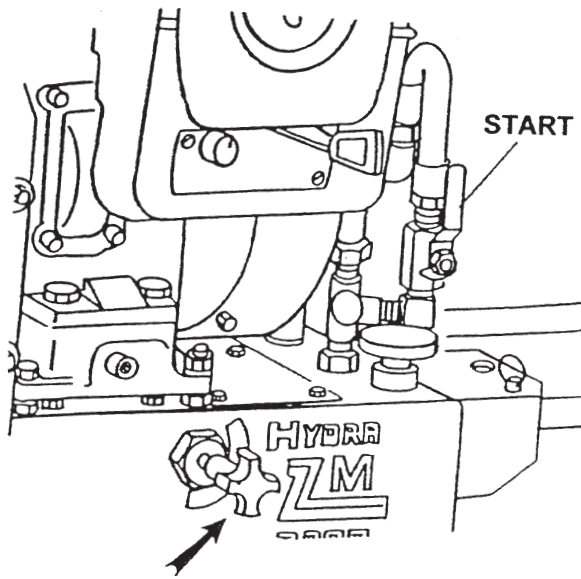

FIGURE 3.

5. Turn the Pressure Adjustment Knob counterclockwise to lowest pressure setting. See Figure 3.

6. Open the Pressure Bleed Valve by turning it counterclockwise. This relieves pressure. See Figure 4.

- A. Your new sprayer was tested at the factory with water soluble oil. You must clean the system before spraying to avoid contamination of the sprayed material.

If you are spraying a water based latex, flush with warm soapy water followed by a clean water rinse.

If you are using any other coating, flush with warm soapy water followed by a solvent. Check with the material manufacturer for a compatible solvent.

Place siphon tube assembly into proper solvent or water.

- B. Place waste container below bleed line.
- C. Start engine. Turn Pressure Control Adjustment Knob clockwise (increasing pressure) until pump cycles evenly and solvent flows freely from bleed line.

- D. Close Pressure Bleed Valve by turning it clockwise. This allows the system to pressurize. Hold gun trigger open, without spray tip attached, until the fluid flows smoothly. See Figure 4.

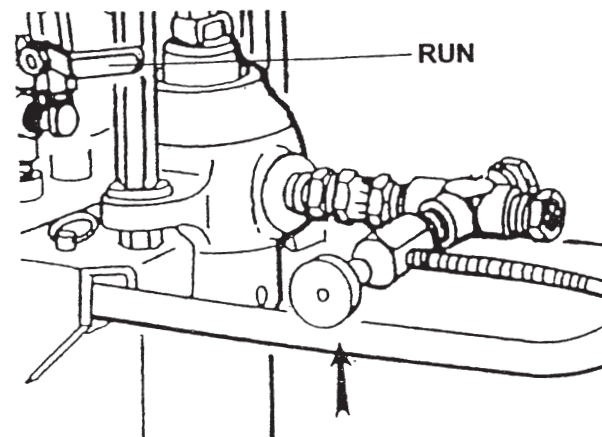

FIGURE 4.

HYDRA M 2000™ 315-555 FLUID PUMP ASSEMBLY SERVICE INSTRUCTIONS

IMPORTANT SERVICE INFORMATION

The 315 Fluid Pump should receive a routine servicing after approximately 1,000 hours of use. The appropriate Minor Service Kit should be installed at this time. It is recommended that one Major Service Kit be kept on hand for normal maintenance and emergency repairs.

Packing service life will be extended by the use of Lubrisolv, *Speeflo Part # 310-200* permanent solvent. Fill to 1/4" level in Pump Block (2). Do not use oil or thinners as a lubricant. Use Lubrisolv for upper packings only - **DO NOT USE IN MOTOR OR HYDRAULIC SYSTEM.**

DISASSEMBLY

1. Disconnect Coupling Nut (32).
2. Remove the Stanchion Nuts (26) for disassembly from tank only.
3. Unthread Foot Valve (18), Lock Ring (7) and Cylinder (8).
4. Drop Spring Retainer (5).
5. Remove Displacement Rod (1) by sliding it downward.
6. Remove Packing Spring (4) and Packing Set (3).
7. To loosen Piston Seat (17) and Displacement Rod:
 - a. Hold piston seat in vise.
 - b. Insert 1/2" bar into fluid holes in Displacement Rod (1) and turn.
8. Remove Packing Set (12) and Spring Retainer (10).
9. Remove Lock Nuts (24) to disassembly foot valve and remove Plate (22) and Ball (19).

ASSEMBLY

1. Replace new Packing Set (3) into Pump Block (2). Peak of packings should point toward motor as illustrated.

2. Replace Packing Spring Retainer (5). Replace new "O" Ring (6) into Pump Block (2).
3. Replace new Ball (16) in Piston Seat (17) and replace Spring Retainer (10), Spring (11), Retainer (12) and new Packing Set (14). Peak of packings should point toward foot valve.
4. Tighten Displacement Rod (1) on to Piston Seat.
5. Insert Displacement Rod (1) through Pump Block (2) slowly to avoid damaging Packing Set. (3)
6. Replace new "O" Ring (6) in Pump Block (2).
7. Replace new Ball (19) and new "O" Rings (20 & 21) in Foot Valve (18).
8. Thread Cylinder (8) into Pump Block (2) locking in Spring Retainer (5).
9. Tighten Lock Ring (7).
10. Replace Foot Valve (18) in Cylinder.
11. Connect Upper Connecting Rod (31) to motor by threading Coupling Nut (32) into piston rod of hydraulic motor.

CAUTION: It is necessary to grease the surface of all "O" Rings to avoid the possibility of cutting them on reassembly.

PUMP SERVICE KITS, MINOR PART NO. 315-050			
ITEM NO.	PART NO.	DESCRIPTION	QTY.
3	314-030	Packing Set, Upper	1
6	315-010	"O" Ring, Teflon	1
14	314-040	Packing Set, Lower	1
16	315-700	Ball 1 1/4", SS	1
19	315-180	Ball 1 3/4", SS	1
20	315-122	"O" Ring	1
21	315-009	"O" Ring	1
	753-024	Sealant Tape, Teflon	1

PUMP SERVICE KITS, MAJOR PART NO. 315-500			
ITEM NO.	PART NO.	DESCRIPTION	QTY.
	315-050	Service Kit, Minor	1
1	315-932	Rod, Displacement	1
8	315-951	Cylinder	1

SPECIFICATIONS												
DISPLACEMENT ROD AREA		STROKE LENGTH		DISPLACEMENT VOLUME/STROKE			DISPLACEMENT VOLUME/60 CY/120 STROKES				MOTOR	MOTOR PUMP RATIO
IN ²	CM ²	IN	CM	IN ³	CM ³	LITER	IN ³	GAL.	CM ³	LITER	441-576	1:1
4	25.8	4	10.2	16.0	262	.262	1920	8.3	31,400	31.4		

**HYDRA M 2000™
315-555
FLUID PUMP ASSEMBLY**

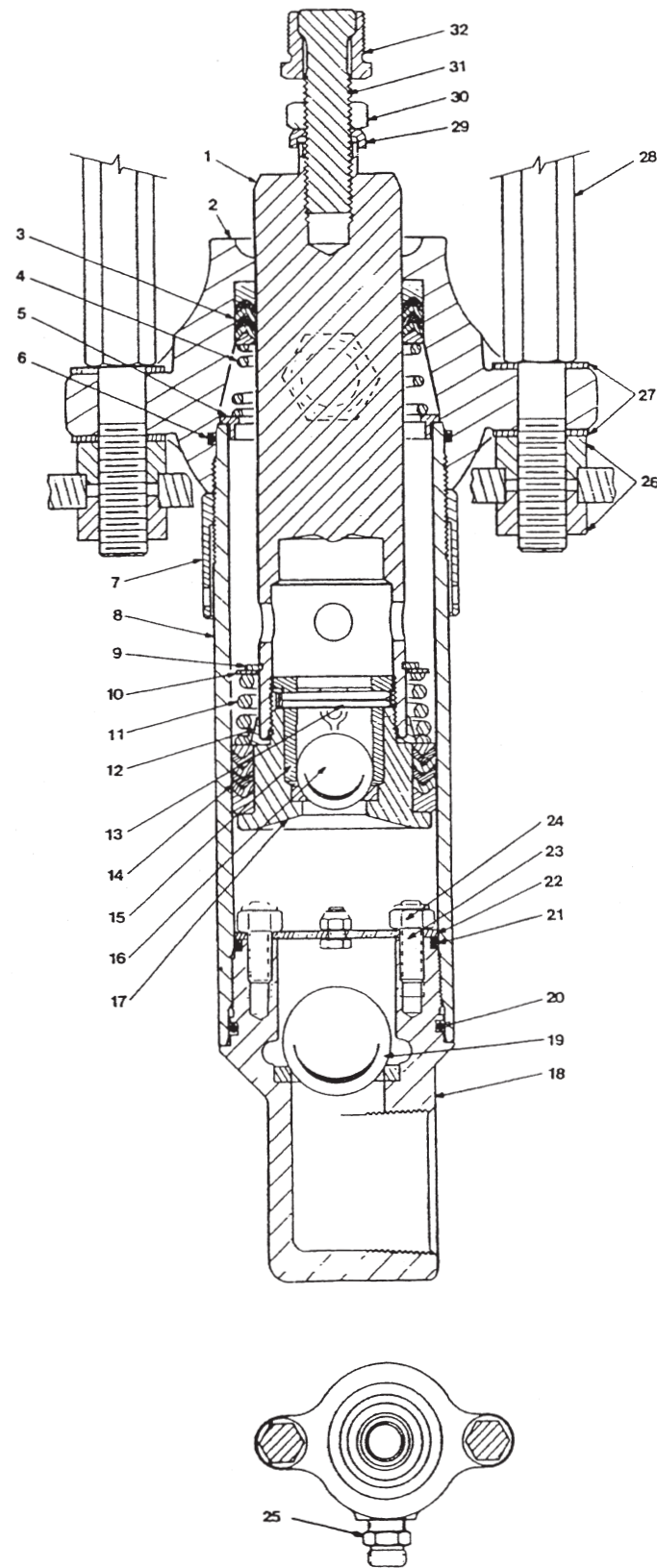

ITEM NO.	PART NO.	DESCRIPTION	QTY.
1	315-932	Rod, Displacement	1
2	315-917	Block, Pump	1
3	314-030	Packing Set, Upper	1
4	314-004	Packing Spring, Upper	1
5	314-003	Retainer, Spring	1
6	315-010	"O" Ring, Teflon	1
7	315-957	Ring, Lock	1
8	315-951	Cylinder	1
9	314-023	Ring, Snap	1
10	314-002	Retainer, Lower	1
11	314-004	Spring, Packing, Lower	1
12	314-981	Retainer, Packing Set	1
13	241-109	Pin, Ball Stop	1
14	314-040	Packing Set, Lower	1
15	316-924	Cage, Ball	1
16	315-700	Ball, 1 1/4", SS	1
17	317-984	Seat, Piston	1
18	317-925	Valve, Foot	1
19	315-180	Ball, 1 3/4", SS	1
20	315-122	"O" Ring	1
21	315-009	"O" Ring	1
22	315-721	Plate, Retainer	1
23	862-447	Stud	3
24	862-411	Nut, Lock	3
25	814-009	Adaptor	1

ASSEMBLY SETS				
ITEM NO.	PART NO.	DESCRIPTION	STD 441-105	55 GAL 441-106
26	870-441	Nut, Spacer	4	
26a	870-401	Nut, Stanchion		2
27	870-004	Washer	6	4
28	441-013	Stanchion	2	
28a	441-010	Stanchion, Long		2
29	441-968	Stirrup	1	1
30	870-021	Nut, Lock	1	1
31	441-959	Rod, Connecting	1	1
32	441-007	Nut, Coupling	*	*
33	180-974	Conrod Extension (not illustrated)		1

* Not included in this assembly

STARTUP

Repeat above starting procedure with paint material. Lock gun trigger and attach spray tip. See the Technical Data Sheet or Operator's Manual on the gun provided for installation and selection of the proper tip size.

8. Test spray pattern. Operate the pump at the lowest hydraulic pressure which provides good atomization. See the Troubleshooting Guide if you are not getting the proper pattern.

9. Operating pressure is adjustable from 500 to 2000 for the Hydra M 2000™ and from 500 to 4000 PSI for the Hydra M 4000™. Turn the Pressure Adjustment Knob clockwise to increase pressure. Do not turn the knob clockwise more than necessary to provide satisfactory atomization. Excess pressure wears out spray tips.

10. When restarting the unit, reduce the pressure at Pressure Control Adjustment Knob and Pressure Bleed Valve.

COLOR CHANGE / CLEAN OUT / FLUSHING

**—IMPORTANT—
PRESSURE RELIEF PROCEDURE**

ALWAYS reduce pressure when you are cleaning a clogged tip, changing a tip, servicing any part of the system, or shutting down. Follow the steps below:

1. Engage the gun trigger lock.
2. Shut off the power source.
3. Close the orange handle shut-off ball valve on the hydraulic hose.
4. Open the Pressure Bleed Valve by turning it counterclockwise at least three full turns.
5. Disengage the gun trigger lock and hold trigger open until flow of material stops.
6. Be certain to hold a metal part of the gun firmly to the side of a grounded metal container.

into a waste container to blow out any clogged particles.

5. Reset the trigger lock in the "Trigger Locked" position. Release the trigger lock and resume spraying

WARNING
THE FLOW FROM THE SPRAY TIP IS AT VERY HIGH PRESSURE. CONTACT WITH ANY BODY PART MAY BE DANGEROUS. DO NOT PLACE FINGER ON GUN OUTLET. DO NOT POINT THE GUN AT ANY PERSON. NEVER OPERATE THE GUN WITHOUT THE PROPER TIP GUARD.

COLOR CHANGE / CLEAN OUT

CAUTION: USE ONLY COMPATIBLE SOLVENTS WHEN CLEANING OUT OIL BASED ENAMELS, LACQUERS, COAL TAR, AND EPOXIES. CHECK WITH THE FLUID MANUFACTURER FOR A RECOMMENDED SOLVENT.

1. Reduce pressure by turning the Pressure Adjustment Knob and the Pressure Bleed Valve on the bleed line counterclockwise. Follow the Pressure Relief Procedure above.

The Pressure Bleed Valve should be turned counterclockwise at least three full turns.

2. Pull siphon tube out of material container.
3. Remove spray tip from gun. Hold gun trigger open until material flow stops.
4. Put siphon tube into wash solvent or water as applicable, and operate pump slowly at low pressure until solvent flows freely from Pressure Bleed valve line.

CLEANING A CLOGGED TIP

1. Follow the Pressure Relief Procedure above.
2. Lock the gun trigger.
3. Unthread the safety tip guard and remove the spray tip. Wash the tip in solvent and use a tip probe to remove any clogged material.
4. Release the gun trigger lock and spray briefly

COLOR CHANGE / CLEANOUT / FLUSHING

5. Close Pressure Bleed Valve and hold gun trigger open until solvent flows freely from gun. If solvent is not too dirty, recirculate it by flowing gun stream back into solvent container. Use additional clean solvent and repeat procedure if necessary.
6. Check gun strainer screen and pump outlet filter screen daily. Use 50 mesh screens with spray tip size .018 and larger. Use 100 or 200 mesh screens with spray tip sizes .015 and smaller.
7. Replace paint filter cap to maximum clockwise

- rotation. The filter cover should be hand removable after the first or second use with new Teflon "O" Ring. **IMPORTANT:** "O" Ring must have Teflon backup washer to seal properly.
8. If unit has been spraying a water soluble material, flush with water and then repeat procedure with mineral spirits or Varsol solvent.
 9. Wash spray tip in solvent. Blow tip clean with air pressure directed through the tip in the reverse direction.

MAINTENANCE

HYDRAULIC SYSTEM

1. Check the hydraulic fluid daily. It should read "Full" on the dipstick. If it is low, add only **Speeflo Coolflo, Part # 430-361**. Never add or change hydraulic fluid except in a clean dust free area. Contamination of the hydraulic fluid will shorten Hydraulic Pump life and may void warranty.

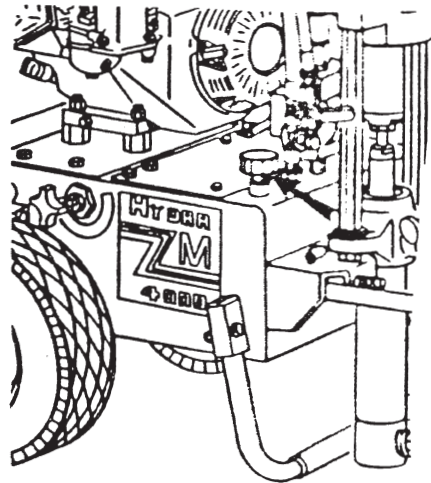

FIGURE 5

2. Change the hydraulic fluid every six months. Drain old fluid from tank and fill with 5 gallons of **Coolflo**. *Start operation of the system at just enough pressure to operate the fluid pump. Run the system at this low pressure for at least 5 minutes. This removes air from the system. Check the fluid level after this procedure.*
3. The Hydraulic System has an external replaceable Hydraulic Filter. Change the filter every six months.
4. The Hydraulic Pump should not be serviced in the field. If service on the Hydraulic Pump is required, it must be returned to Speeflo.

GENERAL FLUID PUMP MAINTENANCE

If the paint pump is going to be out of service for an extended period of time, it is recommended that following cleanup a kerosene and oil mixture be introduced as a preservative. Packings may tend to dry out from lack of use. This is particularly true of the upper packing set for which upper packing lubricant, **Lubrisolv, Speeflo Part # 310-203**, is recommended in normal usage. A sample of **Lubrisolv** accompanies each new unit. Do not substitute water or paint solvent for **Lubrisolv**. Ordinary oil may contaminate the paint material and is not recommended.

If the paint pump has been out of service for an extended period of time, it may be necessary to prime the suction by pouring some of the paint solvent into the inlet siphon tube to restart. *It is extremely*

HYDRA M™ 441-575 & 441-576 HYDRAULIC MOTOR SERVICE INSTRUCTIONS

9. Insert Snap Ring (18) to hold Spacer (17) in place.
10. Place new "O" Ring (11) and new Back-up Ring (10) on Cylinder Head (15) and lower cylinder head on to Cylinder (28), Shifter Actuator Assembly (19) and Upper Stanchions (14) with Washers (9).
11. Raise the Cylinder Head (15) to apply vise grips to the Shifter Actuator Rod (19). Pass the shifter actuator rod through the Valve Spool (12). Clean and Loctite the shifter rod threads and install and tighten Lock Nut (3).
12. Thread Reset Assembly (1) with new "O" Ring (2) into Cylinder Head (15), insert new Balls (4), new Springs (5), and replace Trip Retainers (7) together with new "O" Rings (6) into Cylinder Head (15).
13. Place Stanchion Nuts (8), Washers (9) on Upper Stanchions (14). Tighten Stanchion Nuts (8) alternately.
14. Attach Tube (36) to Tee Assembly (35) and Elbow (37) by tightening connector nuts.

Note: Areas where Loctite Sealant is applied must be free of oil and grease.

MOTOR SERVICE KIT, MINOR PART NO. 441-071			
ITEM NO.	PART NO.	DESCRIPTION	QTY.
2	441-217	"O" Ring	1
3	858-811	Nut	1
4	569-016	Ball, SS	2
5	441-005	Spring, Trip	2
6	141-007	"O" Ring	2
10	441-149	Ring, Back-up	2
11	441-148	"O" Ring	2
13	441-152	"O" Ring	3
20	441-238	Ring, Wear	1
22	441-249	Seal, Piston	1
23	441-026	"O" Ring	1
24	441-024	Ring, Back-up	1
29	441-151	Gasket, Cushion	1
31	441-234	Piston Tube Seal	1
32	445-237	Ring, Wear	1
	426-051	Loctite Sealant	1

MOTOR SERVICE KIT, MAJOR PART NO. 441-701			
ITEM NO.	PART NO.	DESCRIPTION	QTY.
	441-071	Motor Service Kit, Minor	1
12	441-908	Valve Spool / Sleeve Set	1
19	441-377	Shifter Actuator Assembly	1

**HYDRA M™ & HYDRA PRO SUPER™
441-575 & 441-576 HYDRAULIC MOTOR
SERVICE INSTRUCTIONS**

IMPORTANT: Use of non-Speeeflo manufactured service parts may void warranty. This motor contains hydraulic fluid. Take precautions to protect the immediate area from oil damage upon disassembly.

DISASSEMBLY INSTRUCTIONS

CAUTION: DISASSEMBLE THIS MOTOR IN A CLEAN DUST FREE AREA. ANY DUST OR DIRT CONTAMINATION OF THIS ASSEMBLY WILL SHORTEN THE SERVICE LIFE OF THIS MOTOR AND THE HYDRAPAC ROTARY PUMP.

1. Release Set Screw (26) and remove Coupling Nut (27). Push out Nylon Button (26).
2. Remove Reset Assembly (1) and "O" Ring (2).
3. Unthread Connector Nuts (35, 37) and release Tube (36).
4. Unscrew Upper Stanchion Nuts (8), remove Washer (9).
5. Raise Cylinder Head (15) high enough to secure the Shifter Actuator Rod (19) with vise grips. Place a socket wrench on the Lock Nut (3).
6. Unthread the Lock Nut (7).
7. Lift Cylinder Head (15) from Upper Motor Stanchions (14). Remove "O" Ring (11) and Back-up Ring (10).
8. Carefully lift Cylinder (28) and Piston Tube Assembly (25) from Motor Base (30). Separate the cylinder and piston tube assembly. Remove "O" Ring (11) and Back-up Ring (10) from motor base. Remove Cushion Gasket (29).
9. Remove Piston Seal (22) and Wear Ring (20).
10. Remove Piston Tube Seal (31), Wear Ring (32) and Wiper (33) from Motor Base (30).

**DISASSEMBLY OF CYLINDER HEAD
AND SHIFTER ACTUATOR ROD**

1. Remove Trip Retainers (7) along with "O" Rings (6), Trip Springs (5) and Balls (4) from Cylinder Head (15).
2. Remove Snap Ring (18) with snap ring pliers.
3. Carefully lift out Valve Spool (12) with needle nose pliers.
4. Using a nylon rod or Spool Driver (P/N 990-009) from the top, push the Valve Sleeve (12) straight out of the Cylinder Head (15).

5. Place Piston Tube Assembly (25) in horizontal position with bottom of Assembly into heavy-duty vise. **WARNING: DO NOT MAR CHROMED SURFACE.** Support the Piston Tube Assembly (25) in the horizontal position with wood blocks and grip the flats of Piston (21) with a 2 1/4" flat wrench to unthread Piston (21).
6. Remove "O" Ring (23) and Back-up Ring (24) from Piston (21).

REASSEMBLY

Wash all parts thoroughly with Coolflo™, Part No. 430-361. For routine servicing, use all new parts from Motor Service Kit, Minor, Part # 441-071. **DO NOT ATTEMPT TO REPLACE 441-234 SEAL (31) WITHOUT SPEEFLO INSTALLATION TOOL, PART # 990-002.**

For major overhaul, replace all parts contained in Motor Service Kit, Major, Part # 441-701. Inspect all other parts for abnormal wear or damage and replace if necessary.

1. Install new Lower Piston Tube Seal (31) in Motor Base (30) using Tool, Part # 990-009. Install new "O" Ring (11) and new Back-up Ring (10) in Motor Base (30).
2. Slide Piston Tube Assembly (25) into motor base from below.
3. Place new "O" Ring (23) and new Back-up Ring (24) onto Piston (21).
4. Clean and coat the threads of the Piston (21) with Loctite Sealant, Part # 426-051, and place Shifter Actuator Assembly (19) with Piston (21) into piston tube. Tighten Piston (21) securely. **WARNING: DO NOT MAR CHROMED SURFACE.**
5. Place new Piston Seal (22) and new Wear Ring (20) on Piston (21).
6. Push piston tube to the top of its stroke and place Cylinder (28) over piston tube and seat the Cylinder (28) on the Motor Base (30) over the new Cushion Gasket (29).
7. Push the Valve Sleeve and Spool (12) straight into the Cylinder Head (15).
8. Place Spacer (17) behind the Valve Sleeve and Spool Assembly (12).

MAINTENANCE

important that the threads on the inlet siphon hose coupling are properly sealed. Any air leakage will produce erratic operation of pump and may damage the system. The up and the down strokes should be approximately equal in time. That is, one should not be faster than the other. A fast up or down stroke may indicate air in the system or malfunctioning valve or seats. See the Troubleshooting Guide.

HYDRAULIC MOTOR & FLUID PUMP SERVICE

See the individual Technical Data Sheets for maintenance and service instructions on the reciprocating hydraulic motor and the fluid pump.

BASIC ENGINE MAINTENANCE

- For detailed engine maintenance and technical specifications refer to the separate Honda Engine Owner's Manual.
- All service to the engine should be performed by an authorized Honda power equipment dealer. To locate a dealer in your area, look in the Yellow Pages of your telephone directory under Gasoline Engines, Garden & Lawn Equipment & Supplies, Lawnmowers, etc.
- The Honda engine is warranted exclusively by Honda Motor Co. For assistance call: (404) 497-6400.
- Use a premium quality detergent motor oil certified to meet or exceed U.S. Automotive requirement SG.SF/CC.CD. SAE 10W30 is recommended for general all temperature use. Other viscosities may be required in other climates.
- Recommended spark plug: BPR6ES (NGK) W20EPR-U (NIPPONDENSO)
Gap the plug to .028 - .031 in (0.70 - .80 mm)
Always use a spark plug wrench.

DAILY: Check engine oil level. Fill as necessary.
Check gasoline level. Fill as necessary.

WARNING: FOLLOWING FUELING PROCEDURE ON PAGE 10.

FIRST 5 HOURS: Change engine oil.

EVERY 25 HOURS: Change engine oil.

WEEKLY: Remove the air filter cover and clean the element. In very dusty environments, check the filter daily. Replace the element as needed. Replacement elements can be purchased from your local Honda dealer.

ENGINE OPERATION AND SERVICE

1. Clean and oil air filter pad on gasoline engine every 25 hours or once weekly. Do not permit the air intake screen around the fly wheel of the gas engine to load up with paint or trash. Clean it regularly. The service life and efficiency of the gas engine model depends upon keeping the gasoline engine running properly. Change the oil in the engine every 25 hours. Failure to observe this may result in engine overheating. Consult the engine manufacturer's service manual provided.
2. To conserve fuel, service life, and efficiency of the unit **always operate the gasoline engine at the lowest RPM at which it runs smoothly without laboring and delivers the amount required for the particular painting operation. Higher RPM does not produce higher working pressure.** The gasoline engine is connected to the Hydraulic pump by a pulley combination designed to produce full paint delivery.
3. The warranty on gasoline engines or electric motors is limited to the original manufacturer.

**TROUBLESHOOTING GUIDE
AIRLESS SPRAYING**

CONDITION	POSSIBLE CAUSE	CORRECTION
Poor spray pattern and / or tails at top and bottom of the spray pattern.	Worn or incorrect tip and/or insufficient atomization. Hose size or length is too small or too long. Dirty filter.	Be sure tip is not worn. Increase pressure. Lower viscosity. Reduce surface tension by increasing hose size to minimize pressure drop through hose and/or reduce hose lengths. Use preorifice disc (H-Disc).
Gun drips or throws a drop at the beginning or end of the spray pattern.	Needle may not be seating correctly. Increase spring tension.	Needle-orifice combination should be factory relapped. Needle packing may be too tight. Loosen as much as possible without leakage. Turn adjusting screw on back of gun clockwise to increase tension or use the green HP spring, Part # 701-098.
Spray tip stops up frequently.	Particles too large for spray tip are passing filter and/or gun screen.	Use 100 mesh gun screen, instead of 50 mesh, for small spray tips. Use 100 mesh screen in pump filter. Strain paint.
Spray pattern changes with pump cycle.	Restrictions in the fluid system.	Check gun and pump filter screens. Always clean screens before they load up.
Irregular flow of material. One stroke faster than the other	Packings are worn or valve balls are not seating. Restriction in siphon system.	Check siphon hose assembly to be sure no air is entering, then recheck all threaded fittings for leakage. See Troubleshooting - Fluid Section for additional service information.
Spitting	Air in system Dirty gun.	Inspect for siphon hose leak. Disassemble and clean gun.
Gun does not spray any fluid	Suction hose leak. No paint. Plugged foot valve. Plugged filters or tip. Ball check valve stuck open.	Inspect for siphon hose leak. Check fluid supply. Remove, clean, inspect foot valve. Clean filters or tip. Clean and inspect pump ball check valve.

**HYDRA M™ & HYDRA PRO SUPER™
441-575 & 441-576 HYDRAULIC MOTOR**

ITEM NO.	PART NO.	DESCRIPTION	441-575	441-576
			QTY.	QTY.
1	441-032	Reset Assembly	1	1
1a	441-031	Cap (1)		
1b	441-041	Button, Reset (1)		
1c	441-029	Spring, Reset (1)		
1d	441-027	Body (1)		
1e	441-030	"O" Ring (1)		
1f	441-028	Pin, Reset (1)		
2	441-217	"O" Ring	1	1
3	858-811	Nut	1	1
4	569-016	Ball	2	2
5	441-005	Spring, Trip	2	2
6	141-007	"O" Ring	2	2
7	441-979	Retainer	2	2
8	870-401	Nut, Stanchion	2	2
9	870-004	Washer, Stanchion	6	6
10	441-149	Ring, Back-up	2	2
11	441-148	"O" Ring	2	2
12	441-908	Valve Spool/Sleeve	1	1
13	441-152	"O" Ring	3	3
14	441-015	Stanchion	2	2
15	441-916	Head, Cylinder	1	1
16	191-668	Adaptor	1	1
16a	194-114	"O" Ring (1)		
16b	194-113	"O" Ring (1)		

ITEM NO.	PART NO.	DESCRIPTION	441-575	441-576
			QTY.	QTY.
17	441-211	Spacer	1	1
18	314-072	Ring, Snap	1	1
19	441-377	Shifter Actuator	1	1
20	441-238	Ring, Wear	1	1
21	442-978	Piston	1	1
22	441-249	Seal, Piston	1	1
23	441-026	"O" Ring	1	1
24	441-024	Ring, Back-up	1	1
25	441-932	Piston Tube	1	
25a	441-931	Piston Tube		1
26	441-937	Set Screw	1	1
27	431-007	Nut, Coupling	1	
27a	441-007	Nut, Coupling		1
28	441-312	Cylinder	1	1
29	441-151	Gasket, Cushion	1	1
30	441-945	Base, Motor	1	1
31	441-234	Seal, Piston Tube	1	1
32	445-237	Ring, Wear	1	1
33	441-025	Wiper, Piston Tube	1	1
34	432-640	Elbow	1	1
35	441-017	Tee	1	1
35a	432-611	"O" Ring Set (1)		
36	441-789	Tube	1	1
37	432-729	Elbow	1	1
37a	432-611	"O" Ring Set (1)		

**HYDRA M™ & HYDRA PRO SUPER™
441-575 & 441-576 HYDRAULIC MOTOR**

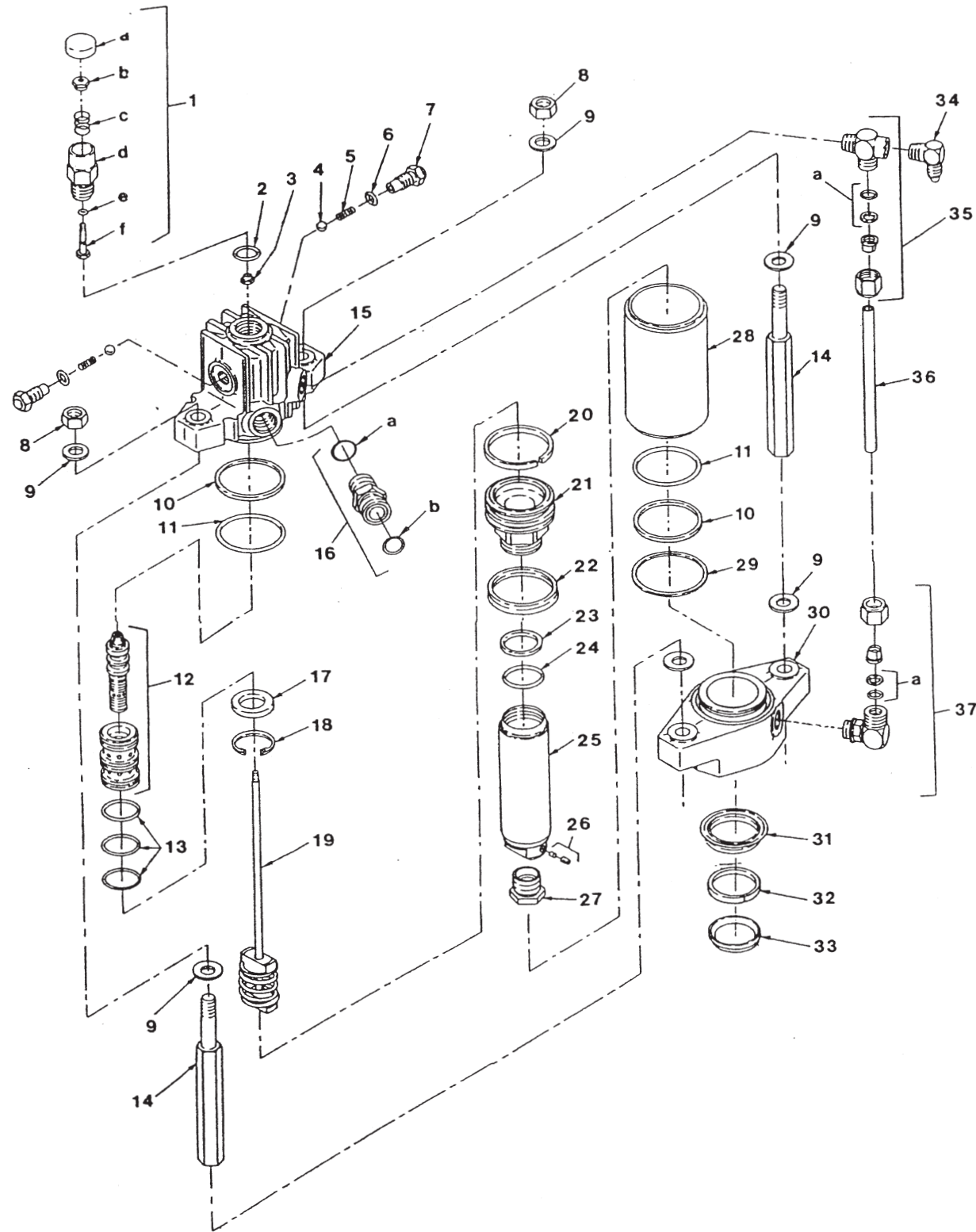

**TROUBLESHOOTING GUIDE
SPRAY PATTERNS**

CONDITION	POSSIBLE CAUSE	CORRECTION
<p>TAILS</p>	<p>Inadequate fluid delivery.</p> <p>Fluid not atomizing correctly.</p>	<p>Increase fluid pressure. Change to smaller tip orifice size. Reduce fluid viscosity. Reduce hose length.</p> <p>Clean gun and filter(s). Reduce number of guns using pump.</p>
<p>HOUR GLASS</p>	<p>Inadequate fluid delivery.</p>	<p>Same as above.</p>
<p>DISTORTED</p>	<p>Plugged or worn nozzle tip.</p>	<p>Clean or replace nozzle tip.</p>
<p>PATTERN EXPANDING & CONTRACTING (SURGE)</p>	<p>Suction leak.</p> <p>Pulsating fluid delivery.</p>	<p>Inspect for siphon hose leak.</p> <p>Change to a smaller tip orifice size.</p> <p>Install pulsation dampener in system or drain existing one. Reduce number of guns using pump.</p> <p>Remove restrictions in system, clean tip screen if filter is used.</p>
<p>ROUND PATTERN</p>	<p>Worn tip.</p> <p>Fluid too heavy for tip.</p>	<p>Replace tip.</p> <p>Increase pressure. Thin material. Change nozzle tip.</p>

**TROUBLESHOOTING GUIDE
HYDRAULIC MOTORS**

CONDITION	CAUSE	CORRECTION
Oil motor stalls at bottom. (No unusual heat problems.)	Fluid pump piston seat unthreaded. Valve sticking or oil motor trip rod shifter assembly separated.	If connecting rod is okay, remove cylinder head plug and pop valve down. Replace plug and start machine. If machine cycles up and stops at bottom again, then problem is piston seat on fluid pump. Check piston seat. Repair or replace as necessary. If piston seat is okay and problem does not change, check oil motor. Remove valve and check for scratches and rough movement when sliding it up and down. Replace valve and spool in this condition. Check trip rod for possible separation.
Oil motor stalls at top. (No unusual heat problems.)	Valve sticking. Broken spring retainer (valve rod assembly) Broken spring on valve rod. Air in hydraulic motor. Air in fluid pump.	Remove valve and check for scratches and rough movement when sliding it up and down. Replace valve and spool in this condition. Replace valve rod assembly. Replace valve rod assembly. Reset Valve. Purge Air, generally accomplished by low pressure cycling of motor/pump assembly for 5 - 10 minutes. Check for causes of air introduction. <ul style="list-style-type: none"> . Loose fittings in tank. . Loose fittings on hydraulic pump. . Loose hose connections. . Low oil in reservoir. Stall at top can occur randomly when fluid pump picks up air. Reset valve. Avoid air in the fluid pump.
Low pressure (okay on down stroke, sluggish on up stroke - high heat). Note: Engine labors on upstroke, idles back at stall on down stroke.	Blown piston seal. Cracked piston.	Before dismantling oil motor, start machine. With pump cycling under pressure, touch the hydraulic cylinder and the head to see if cylinder or head gets hotter. This will help determine if piston seal is blown or piston nut is broken. If heat is on the head, check the O-rings on spool valve. Dismantle oil motor and check piston seals cylinder bore and piston nut. Pay special attention to piston nut. It can be cracked and not show externally.
Low pressure (both strokes - high heat) Note: Engine labors at stall on both strokes.	Blown center O-rings on spool valve. Bad hydraulic pump.	Before dismantling oil motor, start machine. With pump cycling under pressure, touch the head to see if the head becomes hotter. This will help determine if center O-ring is blown on spool valve. If hot, remove valve and replace O-rings. Replace hydraulic pump.

**HYDRA M™ & HYDRA PRO SUPER™
TANK ASSEMBLY & MOBIL KIT**

TANK ASSEMBLY			
ITEM NO.	PART NO.	DESCRIPTION	QTY.
1	434-662	Fan Shroud	1
2	858-001	Washer	7
3	856-924	Screw	7
4	862-436	Screw	4
5	862-002	Washer, Lock	4
6	856-963	Nut	7
7	434-661	Back Plate	1
8	433-006	Spacer	4
9	862-452	Screw	2
10	862-001	Washer, Flat	2
11	862-003	Washer, Copper	2
12	862-002	Washer, Lock	2
13	862-411	Nut, Lock	2
14	860-528	Screw	7
15	860-002	Washer, Lock	14
16	860-524	Screw	7
17	434-676	Plate, Inspection	1
18	434-677	Gasket	1
19	434-622	Tank (FOR HYDRA M 4000™ & HYDRA PRO SUPER™)	1
19a	434-620	Tank (FOR HYDRA M 2000™)	1
20	416-010	Sleeve	1
21	872-431	Nut, Bulkhead	1
22	872-003	Washer, Star	1
23	858-601	Nut	1
24	858-002	Washer, Lock	1
25	101-205	Ground Lug	1
26	858-628	Screw	1
27	432-609	"O" Ring	1
28	434-621	Bushing	1
29	227-033	Pipe Plug	1
30	141-007	"O" Ring	1
31	434-682	Pressure Control Assembly	1
32	185-983	Cotter Key (1)	
33	434-671	Shaft, Pressure Control (1)	
34	866-601	Nut, Jam (2)	
35	970-013	Knob (1)	

MOBILKIT			
ITEM NO.	PART NO.	DESCRIPTION	QTY.
36	434-656	Handle	1
37	434-659	Foot, Rubber	1
38	434-657	Foot	1
39	935-008	Cap	2
40	858-660	Screw	2
41	858-611	Nut, Lock	2
42	434-655	Pin, Lock	4
43	435-641	Axle	1
44	570-010	Pin, Cotter	4
45	670-109	Wheel	2
46	435-659	Bumper	1

HYDRA M™ & HYDRA PRO SUPER™
TANK ASSEMBLY & MOBIL KIT

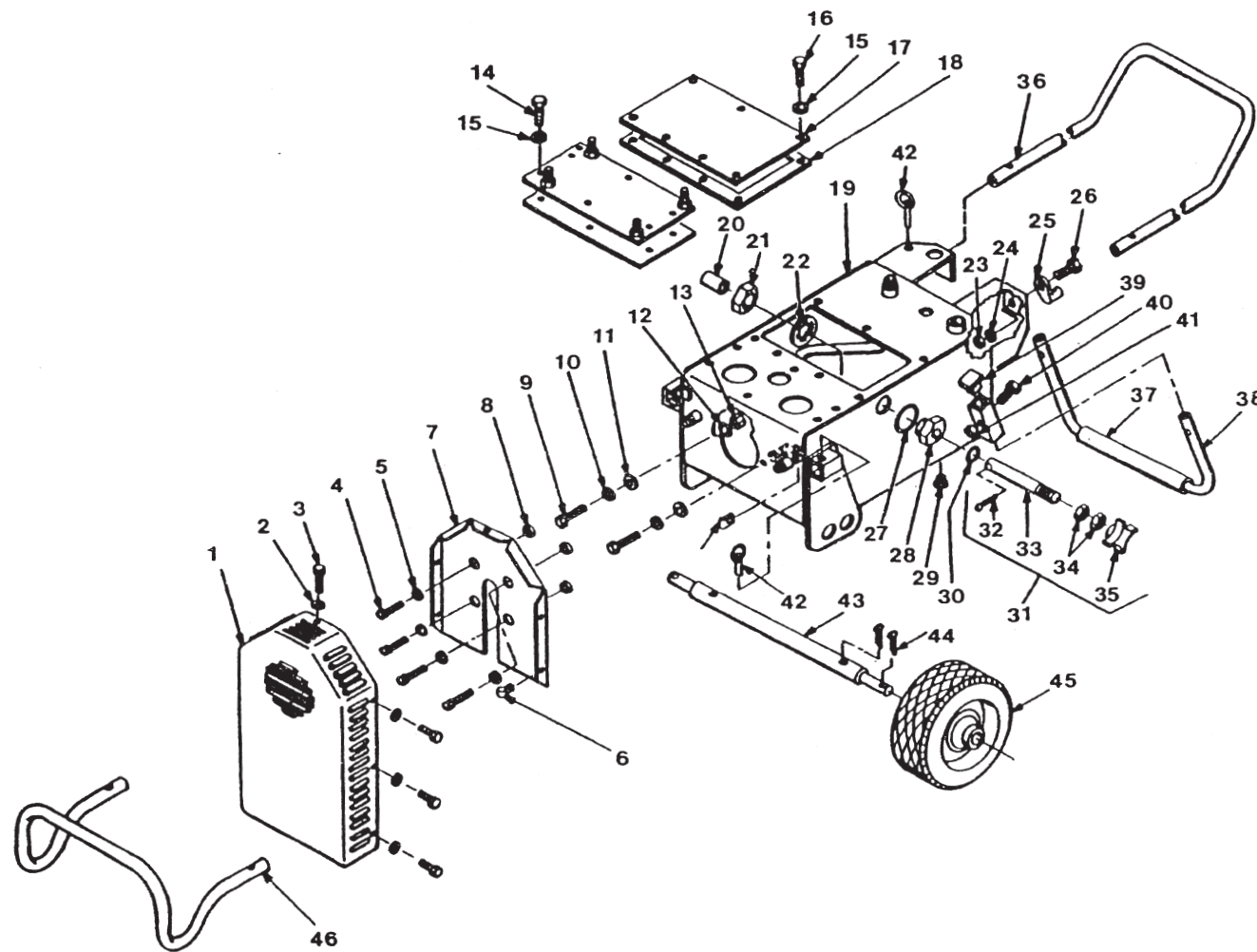

TROUBLESHOOTING GUIDE
FLUID SECTIONS

CONDITION	CAUSE	CORRECTION
Pump delivers on upstroke only or goes up slowly and down fast. (Commonly called downstroke dive.)	Lower foot valve ball is not seating due to trash or wear.	Remove foot valve assembly. Clean and inspect. Test foot valve by filling with water; if ball fails to seal the seat, replace ball.
	Material too viscous to siphon.	Thin material- contact manufacturer for proper thinning procedures.
	Air leaking in on siphon side or damaged siphon hose. Siphon may be too small for heavy material.	Tighten all connections between pump and paint container. If damaged, replace. Switch to larger diameter siphon set.
Pump delivers on down stroke only or goes up fast and down slowly.	Upper ball is not seating due to trash or wear.	Check upper seat and ball with water. If ball fails to seal seat, replace.
	Lower packing set is worn.	Replace packing set if worn.
Pump moves up and down fast, not delivering material.	Material container is empty or material is too thick to flow through siphon hose.	Refill with new material. If too thick, remove siphon hose and immerse pump or add thinner to material. Change to bigger siphon set. Open bleed valve to remove air and restart pump.
	Bottom ball stuck to foot valve seat.	Remove foot valve. Clean ball and seat.
	Siphon hose is kinked or loose.	Straighten.
Pump moves up and down slowly when spray gun is shut off.	Loose connections. Bleed valve is open partially or bleed valve is worn. Lower packing set is worn.	Check all connections between pump and gun. Tighten as necessary. If material is flowing from bleed hose, close bleed valve or replace if necessary. Should none of above be evident, replace lower packing.
	Upper and/or lower ball not seating.	Reseat balls by cleaning.
Not enough fluid pressure at gun.	Spray tip is worn.	Replace.
	Outlet filter or gun filter is clogged	Clean or replace filter.
	Low voltage and/or inadequate amperage.	Check electrical service. Correct as required.
Pump chatters on up or down stroke.	Hose size or length is too small or too long.	Increase hose size to minimize pressure drop through hose and/or reduce hose lengths.
	Solvent has caused upper packing to swell.	Replace packings.

**HYDRA M 2000™
MAJOR COMPONENTS**

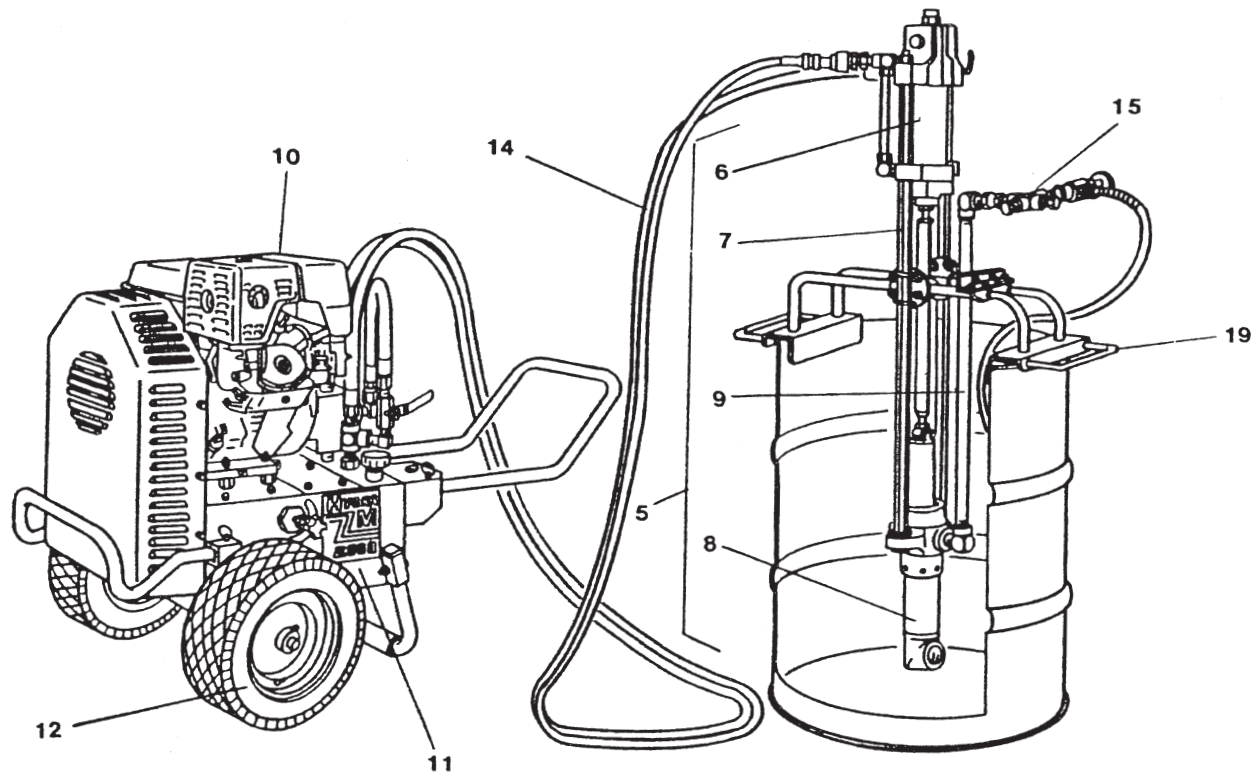
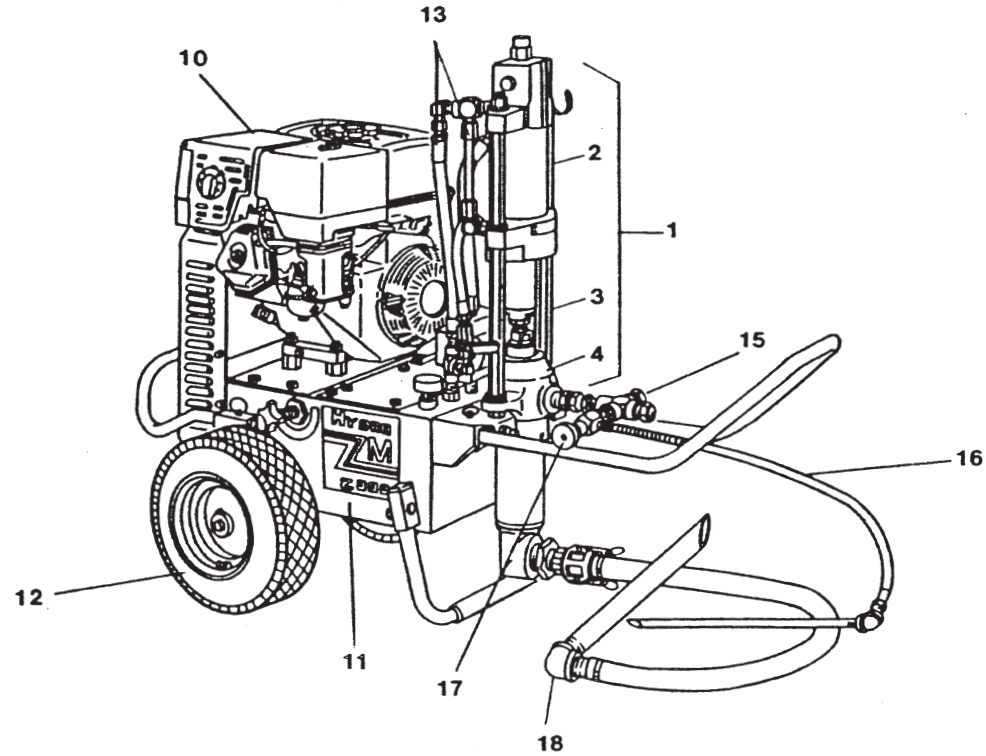

**HYDRA M™ & HYDRA PRO SUPER™
ENGINE DRIVE & HYDRAULIC SYSTEM**

ENGINE / DRIVE ASSEMBLY PART NO. 433-601			
ITEM NO.	PART NO.	DESCRIPTION	QTY.
1	433-007	Fan Pulley Assembly	1
2	862-739	Screw (1)	
3	862-002	Washer, Lock (1)	
4	433-008	Sleeve (1)	
5	858-634	Screw (3)	
6	858-002	Washer, Lock (3)	
7	432-646	Fan Retainer Ring (1)	
8	432-631	Fan (1)	
9	433-001	Pulley (1)	
10	980-308	Key	1
11	980-340	Engine, 13 HP Honda	1
12	862-412	Nut	4
13	862-002	Washer, Lock	4
14	433-005	Pad, Mounting	4
15	862-482	Screw	4
16	433-004	Plate, Motor Mount	1
17	434-652	Gasket, Motor Mount	1
18	416-310	Pulley / Hub / Bolt Set	1
19	433-003	Belt	1
20	138-228	Spacer	1
21	434-641	Battery, 12 V	1
22	434-617	Bracket, Battery	1
23	433-009	Bracket, Regulator	1
24	858-636	Screw	2
25	858-611	Nut, Lock	2
26	101-216	Cable, Battery	2

HYDRAULIC HOSE SET FOR ALL 55 GAL. UNITS PART NO. 432-684			
ITEM NO.	PART NO.	DESCRIPTION	QTY.
63	432-684	Hydr. Hose Set, 15'	1
63a	432-673	Pressure Hose (1)	
63b	434-697	Coupler, Quick Disco. (1)	
63c	434-698	Nipple, Quick Discon. (1)	
63d	814-006	Nipple (1)	
63e	432-674	Return Hose (1)	
63f	434-695	Coupler, Quick Discon. (1)	
63g	434-696	Nipple, Quick Discon. (1)	
63h	191-665	Nipple (1)	

HYDRAULIC SYSTEM			
ITEM NO.	PART NO.	DESCRIPTION	QTY.
27	432-625	Heat Exchanger Assembly	2
28	432-526	Heat Exchanger (1)	
29	742-007	Male Connector (2)	
30	434-673	Connector, Dual Outlet	2
31	434-601	Gasket	1
32	432-601	"O" Ring	1
33	416-509	Pump	1
34	103-679	Clamp, Hose	1
35	432-686	Hose, Return	1
36	416-524	Spool	1
37	416-581	Button	1
38	416-584	Spring	1
39	416-226	"O" Ring	1
40	185-983	Cotter Key	1
41	416-008	Stem, Adjustment	1
42	441-206	Adaptor/"O" Ring/Nut	1
43	432-150	Elbow * Swivel with Nut	1
44	432-604	Filter, 100 Mesh	1
45	432-676	Tube, Pressure	1
46	432-645	Nut, Tube	1
47	432-644	Ferrule	1
48	872-431	Nut, Lock	1
49	872-002	Washer, Lock	1
50	872-005	Washer, Nylon	1
51	335-010	Filler/Dipstick	1
52	432-607	Adaptor, Bulkhead	1
53	817-003	Tee	1
54	818-001	Elbow	1
55	940-557	Ball Valve	1
56	402-020	Bypass Hose Assembly	1
57	432-871	Filter Assembly High Press.	1
58	432-873	"O" Ring (1)	
59	432-864	Filter Element (1)	
60	431-011	Elbow	1

FOR HYDRA M 2000™			
ITEM NO.	PART NO.	DESCRIPTION	QTY.
61	432-680	Hydraulic Hose Set	1
61a	432-711	Pressure hose (1)	
61b	432-685	Return Hose (1)	

FOR HYDRA M 4000™ AND HYDRA PRO SUPER™			
ITEM NO.	PART NO.	DESCRIPTION	QTY.
62	432-681	Hydraulic Hose Set	1
62a	432-715	Pressure Hose (1)	
62b	432-688	Return Hose (1)	

**HYDRA M™ & HYDRA PRO SUPER™
ENGINE DRIVE & HYDRAULIC SYSTEM**

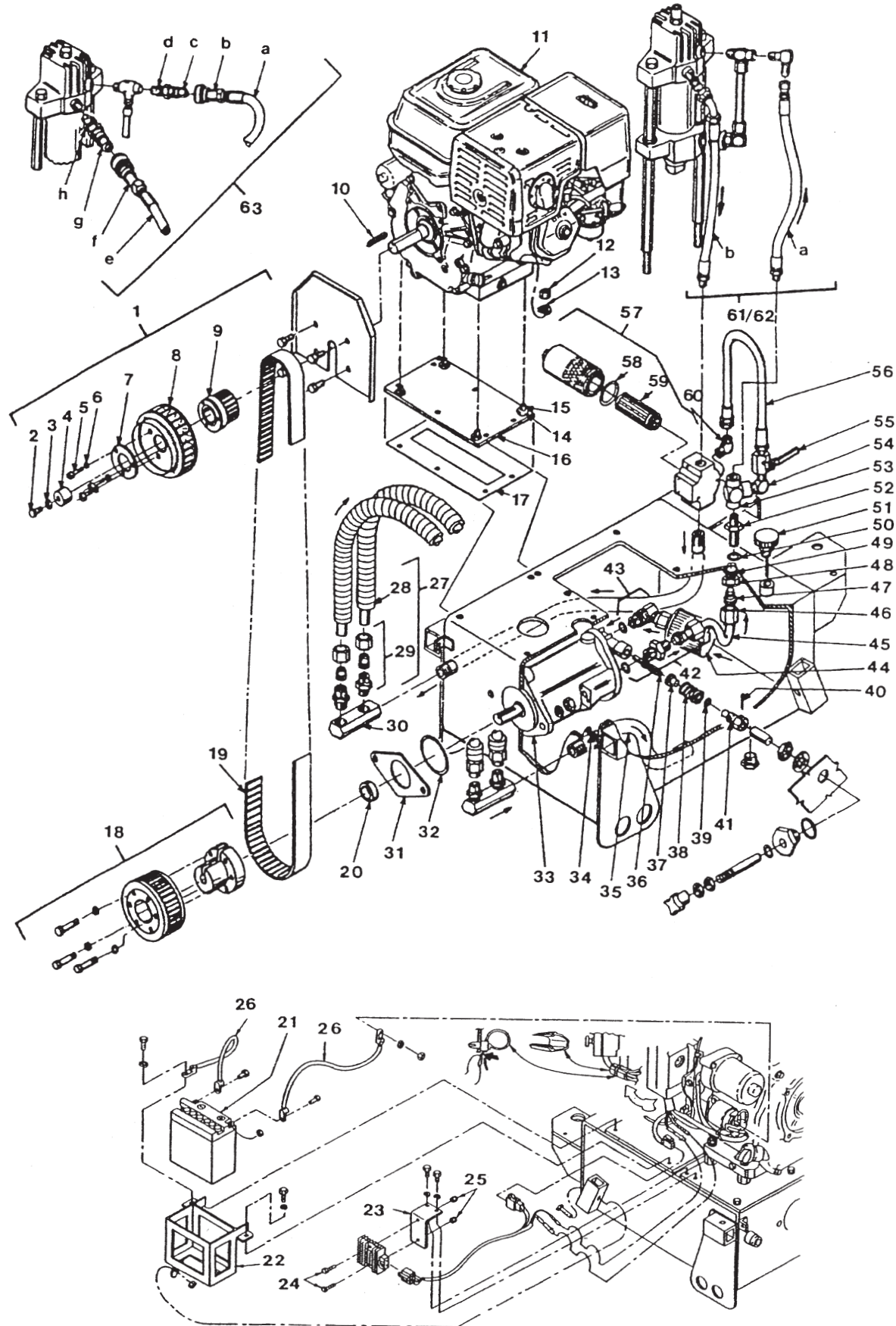

**HYDRA M 2000™
MAJOR COMPONENTS**

ITEM NO.	PART NO.	DESCRIPTION	13 HP HONDA W/OUTLET	13 HP HONDA 55 GAL
			433-860	433-861
1	441-315	Motor Pump Assembly	1	
2	441-576	Motor Assembly (1)		
3	441-105	Assembly Set (1)		
4	315-555	Pump Assembly (1)		
5	441-316	Motor Pump Assembly		1
6	441-576	Motor Assembly (1)		
7	441-106	Assembly Set (1)		
8	315-555	Pump Assembly (1)		
9	840-202	Riser Pipe Assembly (1)		
10	433-601	Engine Drive Assembly, Elec Start	1	1
11	433-702	Hydraulic Tank Assembly	1	1
12	590-312	Mobil Kit	1	1
13	432-680	Hose Set, Hydraulic	1	
14	432-684	Hose Set, Hydraulic, 55 Gal.		1
15	840-207	Outlet Assembly, 1"	1	1
16	103-106	Bleed Line Assembly (1)		
17	945-600	Bleed Valve (1)		
18	103-818	Siphon Hose Assembly 1 1/2" x 6'	1	
19	219-650	Adj. Drum Mount Assembly		1

ALL MODELS ARE EQUIPPED WITH ELECTRIC STARTER

HYDRA M 4000™
MAJOR COMPONENTS

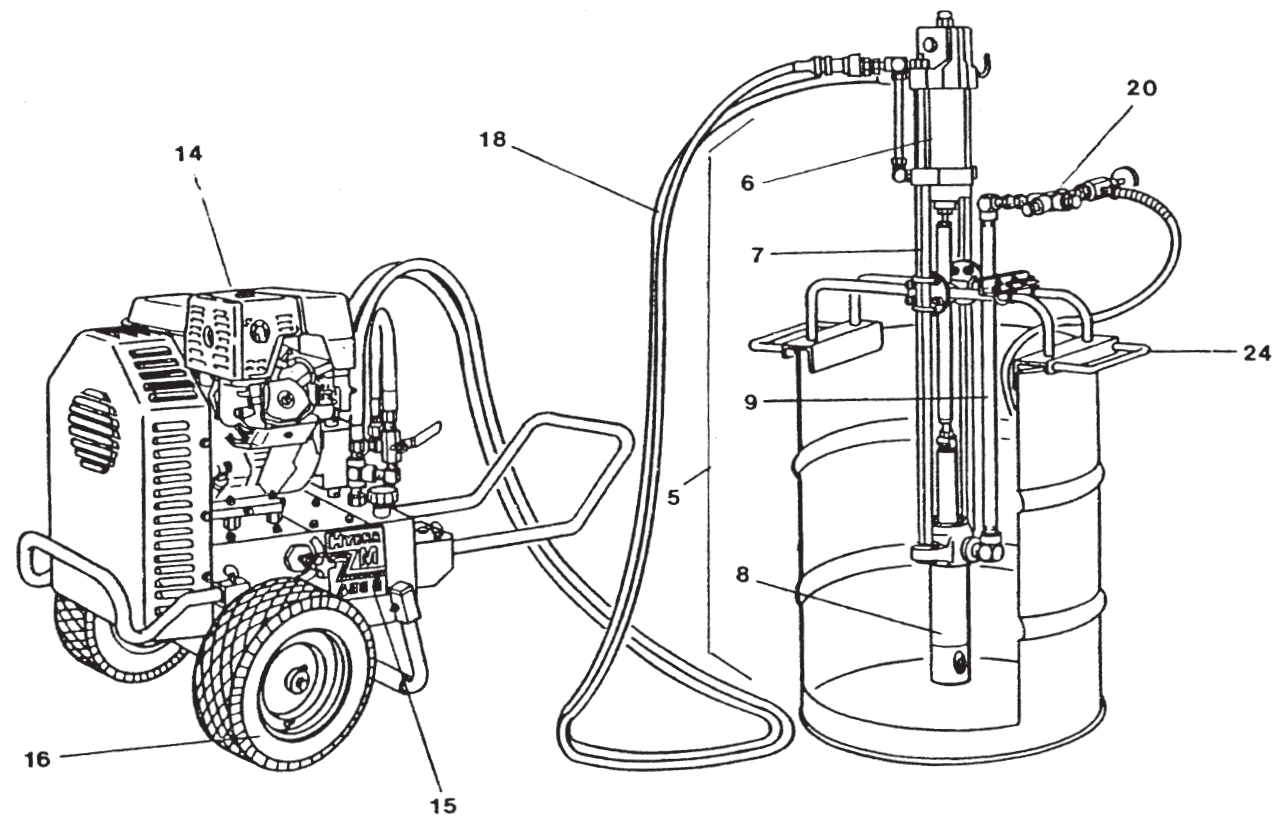
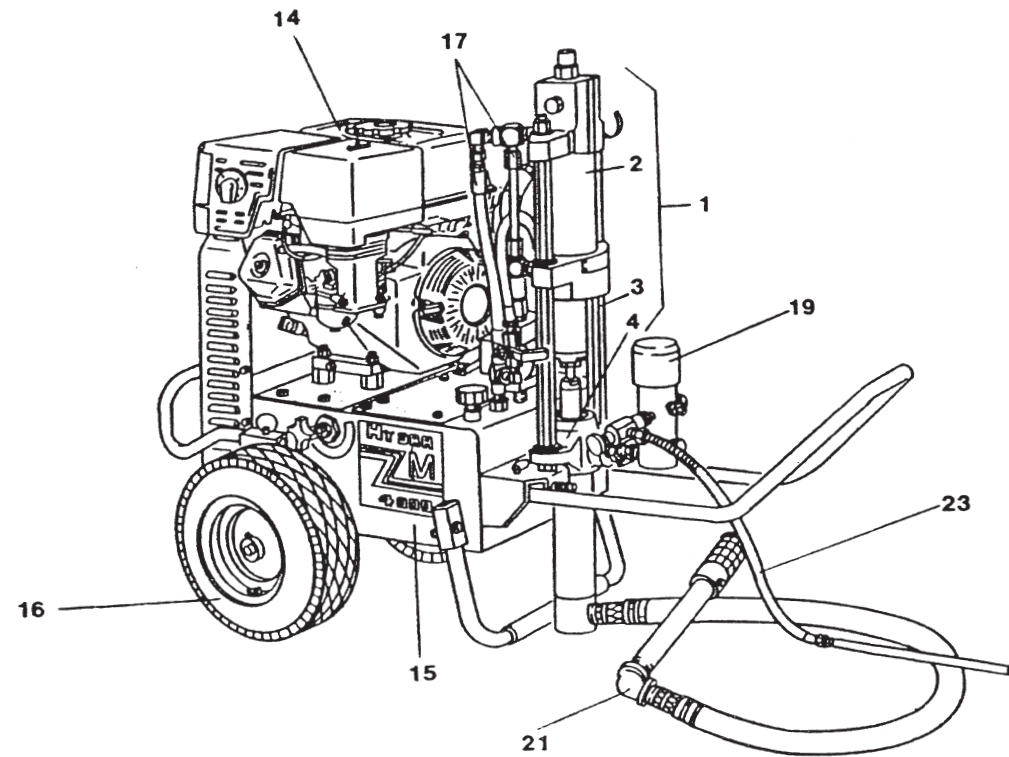

HYDRA M 4000™ & HYDRA PRO SUPER™
MAJOR COMPONENTS

ITEM NO.	PART NO.	DESCRIPTION	HYDRA M 4000™			HYDRA PRO SUPER™
			13 HP HONDA W/OUTLET	13 HP HONDA W/FILTER	13 HP HONDA 55 GAL	13 HP HONDA W/FILTER
			433-800	433-801	433-802	433-810
1	441-246	Motor Pump Assembly	1	1		
2	441-576	Motor Assembly (1)				
3	441-107	Assembly Set (1)				
4	245-555	Pump Assembly (1)				
5	441-247	Motor Pump Assembly			1	
6	441-576	Motor Assembly (1)				
7	441-108	Assembly Set (1)				
8	245-555	Pump Assembly (1)				
9	840-204	Riser Pipe Assembly (1)				
10	441-182	Motor Pump Assembly				1
11	441-575	Motor Assembly (1)				
12	441-101	Assembly Set (1)				
13	185-551	Pump Assembly (1)				
14	433-601	Engine Drive Assembly, Elec Start	1	1	1	1
15	433-701	Hydraulic Tank Assembly	1	1	1	1
16	590-312	Mobil Kit	1	1	1	1
17	432-681	Hose Set, Hydraulic	1	1		1
18	432-684	Hose Set, Hydraulic, 55 Gal.			1	
19	920-559	Filter Assembly, 50 Mesh		1		1
20	840-208	Outlet Assembly 3/4"	1		1	
21	103-812	Siphon Hose, 1 1/4" x 4'	1	1		
22	103-807	Siphon Hose, 1" x 4'				1
23	840-209	Relief Valve w/Bleed Line		1		1
24	219-650	Adj. Drum Mount Assembly			1	

HYDRA PRO SUPER™ is not illustrated

ALL MODELS ARE EQUIPPED WITH ELECTRIC STARTER