



Owner's Manual

For professional use only

**Do not use this equipment
before reading this manual!**

PowerLiner 4900



Model Number:

1 Gun	759-490
2 Gun	759-492

NOTE: This manual contains important warnings and instructions. Please read and retain for reference.

Table of Contents

Safety Precautions	2
Grounding Instructions	3
Gasoline Engine Safety	4
Français	16
Español	18
Specifications	4
Introduction	5
Operation	5
Fueling	5
Setup	6
Preparing to Paint	7
Painting	8
Operating the Front Caster	9
Pressure Relief Procedure	9
Cleanup	9
Cleaning a Clogged Tip	10
Maintenance	10
Daily Maintenance	10
Maintaining the Filter Assembly	10
Maintaining the Hydraulic System	11
Maintaining the Fluid Section	11
Basic Engine Maintenance (gas engine)	11
Replacing the Motor Brushes (electric motor)	12
Adjusting the Tracking on the Front Caster	12
Troubleshooting	13
Airless Gun	13
Fluid Section	13
Hydraulic Motor	14
Spray Patterns	15
Parts Lists and Service Instructions	20
Main Assembly	20
Hydraulic System Assembly	21
Gas Convertokit	22
DC— Electric Convertokit	22
Siphon Hose Assembly	23
Bleed Hose Assembly with Valve	23
Bleed Valve Assembly	23
Wheel Assembly	23
Cart Assembly	24
Hydraulic Motor	26
Fluid Section	28
Filter Assembly	30
Belt Guard Assembly	30
Trigger Assembly	30
SAE O-Ring Fitting Installation	31
Accessories and Service Kits	31
Second Gun Assembly	32
SC-6 Stripping Tip Chart	34
Electrical Schematic	34
Spray Gun Positions	35
Warranty	36

Safety Precautions

This manual contains information that must be read and understood before using the equipment. When you come to an area that has one of the following symbols, pay particular attention and make certain to heed the safeguard.



This symbol indicates a potential hazard that may cause serious injury or loss of life. Important safety information will follow.



This symbol indicates a potential hazard to you or to the equipment. Important information that tells how to prevent damage to the equipment or how to avoid causes of minor injuries will follow.

NOTE: Notes give important information that should be given special attention.

WARNING

HAZARD: Injection injury - A high pressure stream produced by this equipment can pierce the skin and underlying tissues, leading to serious injury and possible amputation. See a physician immediately.

DO NOT TREAT AN INJECTION INJURY AS A SIMPLE CUT! Injection can lead to amputation. See a physician immediately.

The maximum operating range of the sprayer is 3300 PSI / 22.8 MPa fluid pressure.

PREVENTION:

- NEVER aim the gun at any part of the body.
- NEVER allow any part of the body to touch the fluid stream. DO NOT allow body to touch a leak in the fluid hose.
- NEVER put your hand in front of the gun. Gloves will not provide protection against an injection injury.
- ALWAYS lock the gun trigger, shut the pump off, and release all pressure before servicing, cleaning the tip or guard, changing tip, or leaving unattended. Pressure will not be released by turning off the motor. The PRIME/SPRAY valve or pressure bleed valve must be turned to their appropriate positions to relieve system pressure. Refer to the PRESSURE RELIEF PROCEDURE described in this manual.
- ALWAYS keep the tip guard in place while spraying. The tip guard provides some protection but is mainly a warning device.
- ALWAYS remove the spray tip before flushing or cleaning the system.
- The paint hose can develop leaks from wear, kinking and abuse. A leak can inject material into the skin. Inspect the hose before each use.
- NEVER use a spray gun without a trigger lock and trigger guard in place and in good working order.
- All accessories must be rated at or above the maximum operating pressure range of the airless sprayer. This includes spray tips, guns, extensions, and hose.

NOTE TO PHYSICIAN:

Injection into the skin is a traumatic injury. It is important to treat the injury as soon as possible. DO NOT delay treatment to research toxicity. Toxicity is a concern with some coatings injected directly into the blood stream. Consultation with a plastic surgeon or reconstructive hand surgeon may be advisable.

HAZARD: EXPLOSION OR FIRE - Solvent and paint fumes can explode or ignite. Severe injury and/or property damage can occur.

PREVENTION:

- Provide extensive exhaust and fresh air introduction to keep the air within the spray area free from accumulation of flammable vapors.
- Avoid all ignition sources such as static electric sparks, open flames, pilot lights, and hot objects. Connecting or disconnecting power cords or working light switches can make sparks.
- Do not smoke in spray area.
- Fire extinguisher must be present and in good working order.
- Place paint pump in a well ventilated area. Flammable vapors are often heavier than air. Floor area must be extremely well ventilated. The paint pump contains arcing parts that emit spark and can ignite vapors.
- The equipment and objects in and around the spray area must be properly grounded to prevent static sparks.
- Use only conductive or grounded high pressure fluid hose. Gun must be grounded through hose connections.

- Power cord must be connected to a grounded circuit (electric models only).
- Always flush unit into a separate metal container, at low pump pressure, with spray tip removed. Hold gun firmly against side of container to ground container and prevent static sparks.
- Follow the material and solvent manufacturer's warnings and instructions.
- Use extreme caution when using materials with a flashpoint below 70° F (21° C). Flashpoint is the temperature that a fluid can produce enough vapors to ignite.
- Plastic can cause static sparks. Never hang plastic to enclose a spray area. Do not use plastic drop cloths when spraying flammable materials.
- Use lowest possible pressure to flush equipment.

GAS ENGINE (WHERE APPLICABLE)

Always place pump outside of structure in fresh air. Keep all solvents away from the engine exhaust. Never fill fuel tank with a running or hot engine. Hot surface can ignite spilled fuel. Always attach ground wire from pump unit to a grounded object, such as a metal water pipe. Refer to engine owner's manual for complete safety information.

HAZARD: EXPLOSION HAZARD DUE TO INCOMPATIBLE MATERIALS - Will cause severe injury or property damage.

PREVENTION:

- Do not use materials containing bleach or chlorine.
- Do not use halogenated hydrocarbon solvents such as mildewcide, methylene chloride and 1,1,1 - trichloroethane. They are not compatible with aluminum.
- Contact your coating supplier about the compatibility of material with aluminum.

HAZARD: HAZARDOUS VAPORS - Paints, solvents, insecticides, and other materials can be harmful if inhaled or come in contact with the body. Vapors can cause severe nausea, fainting, or poisoning.

PREVENTION:

- Use a respirator or mask if vapors can be inhaled. Read all instructions supplied with the mask to be sure it will provide the necessary protection.
- Wear protective eyewear.
- Wear protective clothing as required by coating manufacturer.

HAZARD: GENERAL - This product can cause severe injury or property damage.

PREVENTION:

- Read all instructions and safety precautions before operating equipment.
- Always disconnect the motor from the power supply before working on the equipment (electric models only).
- Follow all appropriate local, state, and national codes governing ventilation, fire prevention, and operation.
- The United States Government Safety Standards have been adopted under the Occupational Safety and Health Act (OSHA). These standards, particularly part 1910 of the General Standards and part 1926 of the Construction Standards should be consulted.
- Use only manufacturer authorized parts. User assumes all risks and liabilities when using parts that do not meet the minimum specifications and safety devices of the pump manufacturer.
- Before each use, check all hoses for cuts, leaks, abrasion or bulging of cover. Check for damage or movement of couplings. Immediately replace the hose if any of these conditions exist. Never repair a paint hose. Replace it with another grounded high-pressure hose.
- Do not spray outdoors on windy days.
- Wear clothing to keep paint off skin and hair.

Grounding Instructions

Electric models must be grounded. In the event of an electrical short circuit, grounding reduces the risk of electric shock by providing an escape wire for the electric current. This product is equipped with a cord having a grounding wire with an appropriate grounding plug. The plug must be plugged into an outlet that is properly installed and grounded in accordance with all local codes and ordinances.

DANGER — Improper installation of the grounding plug can result in a risk of electric shock. If repair or replacement of the cord or plug is necessary, do not connect the green grounding wire to either flat blade terminal. The wire with insulation having a green outer surface with or without yellow stripes is the grounding wire and must be connected to the grounding pin.

Check with a qualified electrician or serviceman if the grounding instructions are not completely understood, or if you are in doubt as to whether the product is properly grounded. Do not modify the plug provided. If the plug will not fit the outlet, have the proper outlet installed by a qualified electrician.

This product is rated more than 15 amperes and is for use on a circuit having a nominal rating of 120 volts, or the product is for use on a circuit having a nominal rating more than 120 volts, and is factory-equipped with a specific electric cord and plug to permit connection to a proper electric circuit. Make sure that the product is connected to an outlet having the same configuration as the plug. No adapter should be used with this product. If the product must be reconnected for use on a different type of electric circuit, the reconnection should be made by qualified service personnel.



Use only a 3-wire extension cord that has a 3-blade grounding plug and a 3-slot receptacle that will accept the plug on the product. Make sure your extension cord is in good condition. When using an extension cord, be sure to use one heavy enough to carry the current your product will draw. An undersized cord will cause a drop in line voltage resulting in loss of power and overheating. For lengths less than 50 feet, No. 12 AWG extension cords should be used. If an extension cord is to be used outdoors, it must be marked with the suffix W-A after the cord type designation. For example, a designation of SJTW-A would indicate that the cord would be appropriate for outdoor use.

Gasoline Engine Safety



The engine exhaust from this sprayer contains chemicals known to the State of California to cause cancer, birth defects, or other reproductive harm.

1. Honda engines are designed to give safe and dependable service if operated according to instructions. Read and understand the Honda Owner's Manual before operating the engine. Failure to do so could result in personal injury or equipment damage.
2. To prevent fire hazards and to provide adequate ventilation, keep the engine at least 1 meter (3 feet) away from buildings and other equipment during operation. Do not place flammable objects close to the engine.
3. Children and pets must be kept away from the area of operation due to a possibility of burns from hot engine components or injury from any equipment the engine may be used to operate.
4. Know how to stop the engine quickly, and understand the operation of all controls. Never permit anyone to operate the engine without proper instructions.
5. Gasoline is extremely flammable and is explosive under certain conditions.
6. Refuel in a well-ventilated area with the engine stopped. Do not smoke or allow flames or sparks in the refueling area or where gasoline is stored.
7. Do not overfill the fuel tank. After refueling, make sure the tank cap is closed properly and securely.
8. Be careful not to spill fuel when refueling. Fuel vapor or spilled fuel may ignite. If any fuel is spilled, make sure the area is dry before starting the engine.
9. Never run the engine in an enclosed or confined area. Exhaust contains poisonous carbon monoxide gas; exposure may cause loss of consciousness and may lead to death.
10. The muffler becomes very hot during operation and remains hot for a while after stopping the engine. Be careful not to touch the muffler while it is hot. To avoid severe burns or fire hazards, let the engine cool before transporting it or storing it indoors.
11. Never ship/transport sprayer with gasoline in the tank.



DO NOT use this equipment to spray water or acid.



Do not lift by cart handle when loading or unloading.

Warning Labels

Your sprayer has the English language warning labels. If you require these labels in French, German, or Spanish, or require additional English labels, order directly from Speeflo free of charge.

Part #	Language
746-089 745-105	English
745-106 745-107	Spanish
745-108 745-109	French
745-110 745-111	German

Specifications

Gas Sprayer

- Gallons per minute (GPM)1.3 (4.9 LPM)
- Cycle rate per gallon.....87 (23 cycles/liter)
- Maximum tip sizes1 gun = .036" (.91 mm)
2 guns = .026" (.66 mm)
- Maximum pressure3300 psi (22.8 MPa)
- Power.....Honda 4.0 HP, 4-stroke, single cylinder, overhead valve engine w/oil alert
- Fuel capacity.....0.66 US gallons (approx. 3 hours run time)
- Halogenated solvent compatible.....Yes
- Weight.....235 lbs. (107 kg.)
- Inlet paint filter10 mesh "rock catcher"
- Outlet paint filter.....50 mesh, 18 in.²
- Pump inlet3/4" NPT(F)
- Pump outlet.....1/2" NPT(F) to paint filter
- Paint filter hose connections.....1/4" NPS(M)
3/8" NPT(F) (plugged)
- Maximum spraying speed (feet/minute, 4" line width)520 lineal feet (158m)
- Maximum spraying speed (miles/hour, 4" line width).....6 mph (9.7 kph)
- Line width range2"-24" (5-60 cm)
- Dimensions59" L (150 cm) x 27" W (69 cm) x 40" H (102 cm)

Fluid section wetted parts:

Electroless nickel plated ductile iron, electroless nickel plated carbon steel, proprietary Severe Service 500™ hard chrome anti-wear surface, stainless steel, tungsten carbide, Teflon, thiokol impregnated leather, ultra high molecular weight polyethylene.

Introduction

Congratulations on having selected the finest airless sprayer available in the world. Speeflo piston pumps are tireless workhorses — so tough they are virtually indestructible, even under the most severe service. Speeflo designs and builds equipment with superior quality and reliability. Equipment that will last for years with minimal maintenance and downtime. This equipment will make you money year after year. We thank you for your purchase and welcome you to our large and growing family of Speeflo users.

The unique ability of this PowrLiner to operate with either gas or electric power provides you with the flexibility to work indoors or outside where no electricity is available.

Hydraulic drive makes possible the longest stroke and slowest cycling pumps in the industry, which translates into low maintenance and longer life. Electric sprayers operate quietly with no motor starting and stopping.



This PowrLiner is equipped with Speeflo's Severe Service 500™ fluid pump. This technology will give you significantly longer rod, cylinder, and packing life. This double ball piston pump employs a dependable and durable time-tested design. All pumps use a thick hard chrome plating on rod and cylinder parts. This plating process is harder than nitralloy, stainless steel, or hard chrome used by any other paint pump manufacturer and much more abrasion resistant. Highly polished parts reduce friction, extend packing life, and avoid damage from corrosion and abrasion. More than 100,000 of these pumps are in operation around the world.

This PowrLiner offers other cost saving features:

- Freeze-proof pressure control
- Choice of power — gas, electric, or both
- Tungsten carbide valve seats
- Self-adjusting packings
- Exclusive hand-tight swivel foot valve
- Large capacity inline paint filter
- Waterborne compatible
- "Floating Ball" pressure bleed valve
- 5 gallon siphon hose and bleed line assemblies are standard

You have made an excellent choice. We know you will be pleased with your new PowrLiner. Thanks again for selecting Speeflo. We appreciate your business.

Operation

Fueling (gas engine)

WARNING

Gasoline is extremely flammable and is explosive under certain conditions.

- ALWAYS turn the engine off before refueling.
- Refuel in a well-ventilated area.
- Do not smoke or allow flames or sparks in the refueling area or where gasoline is stored.
- Do not overfill the fuel tank. After refueling, make sure the tank cap is closed properly and securely.
- Be careful not to spill fuel when refueling. Spilled fuel or fuel vapor may ignite. If any fuel is spilled, make sure the area is dry before starting the engine.
- Avoid repeated or prolonged contact with skin or breathing of vapor.
- Keep out of the reach of children.

Fuel Specifications

- Use automotive gasoline that has a pump octane number of 86 or higher, or that has a research octane number of 91 or higher. Use of a lower octane gasoline can cause persistent "pinging" or heavy "spark knock" (a metallic rapping noise) which, if severe, can lead to engine damage.

NOTE: If "spark knock" or "pinging" occurs at a steady engine speed under normal load, change brands of gasoline. If spark knock or pinging persists, consult an authorized dealer of the engine manufacturer. Failure to do so is considered misuse, and damage caused by misuse is not covered by the engine manufacturer's limited warranty.

Occasionally you may experience light spark knock while operating under heavy loads. This is no cause for concern, it simply means your engine is operating efficiently.

- Unleaded fuel produces fewer engine and spark plug deposits and extends the life of the exhaust system components.
- Never use stale or contaminated gasoline or an oil/gasoline mixture. Avoid getting dirt, dust, or water in the fuel tank.

Gasolines Containing Alcohol

If you decide to use a gasoline containing alcohol (gasohol), be sure its octane rating is at least as high as that recommended by the engine manufacturer. There are two types of "gasohol": one containing ethanol, and the other containing methanol. Do not use gasohol that contains more than 10% ethanol. Do not use gasoline containing methanol (methyl or wood alcohol) that does not also contain co-solvents and corrosion inhibitors for methanol. Never use gasoline containing more than 5% methanol, even if it has co-solvents and corrosion inhibitors.

NOTE: Fuel system damage or engine performance problems resulting from the use of fuels that contain alcohol is not covered under the warranty. The engine manufacturer cannot endorse the use of fuels containing methanol since evidence of their suitability is incomplete at this time.

Before buying gasoline from an unfamiliar station, try to find out if the gasoline contains alcohol. If it does, confirm the type and percentage of alcohol used. If you notice any undesirable operating characteristics while using a gasoline that contains alcohol, or one that you think contains alcohol, switch to a gasoline that you know does not contain alcohol.

Setup

⚠ WARNING

Read, understand, and follow all warnings before starting or operating this sprayer.

1. Connect the siphon hose to the fluid section and the bleed hose to the bleed valve. They each have factory installed Teflon tape on the male end of the hoses and should be tightened wrench tight.

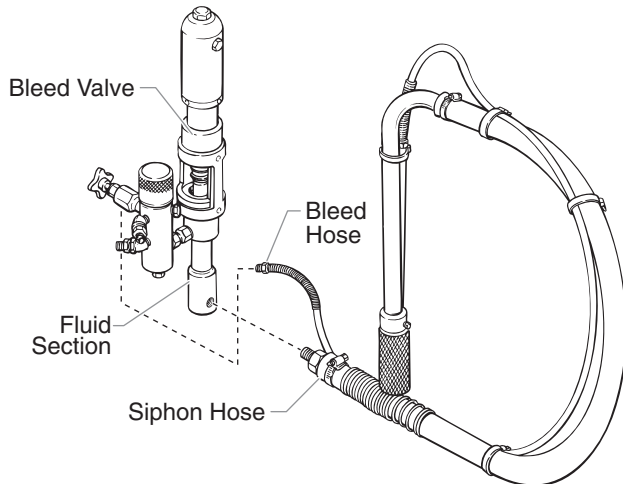

2. Install the gun support bar.

NOTE: The spray gun, hose, and cables are mounted to the gun support bar at the factory.

- a. Loosen the support bar clamps on each side of the cart.
- b. Slide the gun support bar through the cart.
- c. Tighten the support bar clamps to secure the gun support bar in position.

NOTE: The gun support bar and the spray gun(s) can be mounted on either side of the sprayer. Refer to the "Spray Gun Positions" illustration near the back of this manual.

⚠ WARNING

Always follow the Pressure Relief Procedure when shutting the sprayer down for any purpose, including servicing or adjusting any part of the spray system, changing or cleaning spray tips, or preparing for cleanup.

3. Position the first spray gun.
 - a. Disengage the trigger cable from the tensioning clamp.

⚠ CAUTION

Always disengage the trigger cable from the tensioning clamp before making any adjustments to the spray gun position.

- b. Loosen the support bar clamps and slide the gun support bar to the desired horizontal position.
- c. Loosen the gun riser clamp and slide the spray gun to the desired vertical position.

NOTE: The height of the spray gun affects the width of the spray pattern (i.e., the lower the gun, the smaller the line width). Tip size also affects line width.

4. Install the second gun assembly, if desired. Refer to the installation instructions for the second gun assembly in the Parts List section of this manual.

5. Set the trigger selector for proper spray gun operation. The right handlebar triggers the gun or guns. The selector on the trigger must be set for the first gun, both guns, or the second gun.

⚠ CAUTION

Always turn the trigger lock on the spray gun to the locked position before making any adjustments to the trigger selector. Also, release the trigger cable from its block by lifting the cable up and out of the block. There will be a brief triggering of the gun while releasing the trigger cable.

- a. **First Gun** — The first gun position is with the selector in the left position. Push the lever toward the inside of the frame until the pin engages the left plate.

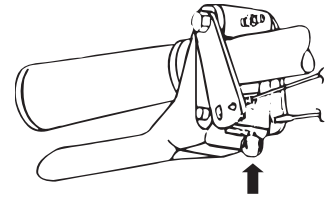

- b. **Both Guns** — The dual gun position is with the selector in the center position. Push the lever toward the center position until the pin engages both plates. The pin must engage both plates.

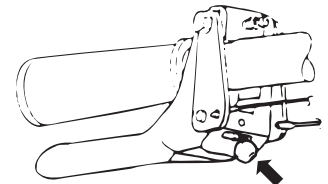

- c. **Second Gun** — The second gun position is with the selector in the right position. Push the lever away from the inside of the frame until the pin engages the right plate.

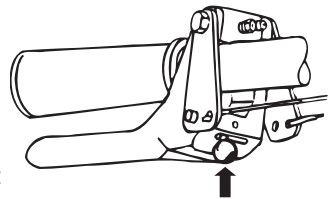

6. Fill the oil cup 1/2 full with Speeflo Piston Lube (P/N 700-925) supplied by the factory. This extends packing life.
7. Check the hydraulic fluid level daily before starting the sprayer. The hydraulic fluid level should be at the "Full" mark on the dipstick. Refer to the Maintenance section of this manual for hydraulic system maintenance instructions.

⚠ CAUTION

Use of Speeflo's Coolflo™ Hydraulic Fluid (P/N 430-361) is mandatory in the hydraulic system. Do not use any other hydraulic fluid. Use of any other hydraulic fluid may seriously damage the hydraulic system and will void the warranty.

8. For gas models, check the engine oil level daily before starting the sprayer. The gasoline engine oil level is determined by the engine manufacturer. Refer to the engine manufacturer's service manual supplied with this sprayer.
9. For electric models, use a 20 amp service outlet. Always locate the electric model within 10 to 15 feet of the service outlet. Use a short electric cable and a long paint hose. Any extension cord will create some voltage drop. If an extension cord is necessary, use only a grounded 3-wire #12 extension cord.

NOTE: If the sprayer is being operated in an area that is overloaded by other appliances or low voltage conditions, it is important to start the sprayer "unloaded." Tip the electric motor forward so that the belt is loosened and the motor starts without full load. This reduces the amperage draw on starting and may avoid tripping the circuit breaker.

- Make sure the sprayer is grounded. All sprayers are equipped with a grounding lug. A grounding cable (not supplied) should be used to connect the sprayer to a true earth ground. Check your local electrical regulations for detailed grounding instructions. See the Accessories and Service Kits section near the back of this manual for grounding cable ordering information.

⚠ WARNING

Proper grounding is important. This applies to both gas and electric powered models. The passage of some materials through the nylon fluid hose will build up a static electric charge, which if discharged, could ignite solvent vapors present and create an explosion.

- Strain all paints with a nylon strainer to ensure trouble free operation and freedom from frequent cleaning of the inlet screen and gun filter.
- Make sure the spray area is well ventilated to prevent hazardous operation with volatile solvents or exhaust fumes.

Preparing a New Sprayer

If this sprayer is new, it is shipped with test fluid in the fluid section to prevent corrosion during shipment and storage. This fluid must be thoroughly cleaned out of the system with mineral spirits before you begin spraying.

⚠ CAUTION

Always keep the trigger lock on the spray gun in the locked position while preparing the system.

- Place the siphon hose into a container of mineral spirits.
- Place the bleed hose into a metal waste container.
- Set the pressure to minimum by turning the pressure control knob fully counterclockwise.

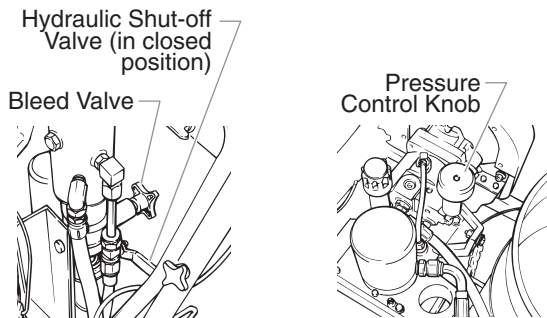

- Open the hydraulic shut-off valve located on the hydraulic pressure hose. The handle should be in line with the hose.
- Open the bleed valve by turning it fully counterclockwise.
- Start the engine or turn on the electric motor.

- To start the gas engine,

- move the fuel valve lever to the open position,
- move the throttle lever to its middle point,
- move the choke lever to the closed position for a cold engine or to the open position for a warm engine,
- turn the engine switch to the ON position, and
- pull the starter rope briskly until the engine starts.

- To start the electric motor, move the ON/OFF switch to the ON position.

- Turn the pressure control knob clockwise approximately 1/3 of the way down to increase pressure until the sprayer cycles evenly and solvent flows freely from the bleed hose.

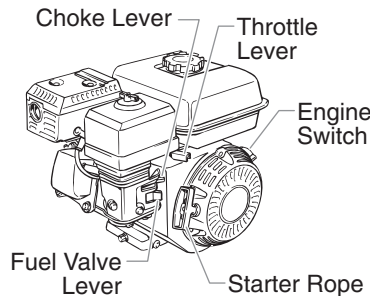

- Allow the sprayer to run for 15–30 seconds to flush the test fluid out through the bleed hose and into the waste container.
- Turn off the sprayer.
 - To turn off the gas engine,
 - set the pressure to minimum by turning the pressure control knob fully counterclockwise,
 - move the throttle lever to the slow position, and
 - turn the engine switch to the OFF position.
 - To turn off the electric motor,
 - set the pressure to minimum by turning the pressure control knob fully counterclockwise,
 - move the ON/OFF switch to the OFF position.

Preparing to Paint

Before painting, it is important to make sure that the fluid in the system is compatible with the paint that is going to be used.

NOTE: Incompatible fluids and paint may cause the valves to become stuck closed, which would require disassembly and cleaning of the sprayer's fluid section.

⚠ CAUTION

Always keep the trigger lock on the spray gun in the locked position while preparing the system.

- Place the siphon hose into a container of the appropriate solvent.

NOTE: If you are spraying a water-based latex, flush with warm, clean water. If you are using any other material, check with the material manufacturer for a compatible solvent.

- Place the bleed hose into a metal waste container.
- Set the pressure to minimum by turning the pressure control knob fully counterclockwise.
- Open the hydraulic shut-off valve located on the hydraulic pressure hose. The handle should be in line with the hose.
- Open the bleed valve by turning it fully counterclockwise.
- Start the engine or turn on the electric motor.
 - To start the gas engine,
 - move the fuel valve lever to the open position,
 - move the throttle lever to its middle point,
 - move the choke lever to the closed position for a cold engine or to the open position for a warm engine,
 - turn the engine switch to the ON position, and
 - pull the starter rope briskly until the engine starts.
 - To start the electric motor, move the ON/OFF switch to the ON position.
- Turn the pressure control knob clockwise approximately 1/3 of the way down to increase pressure until the sprayer cycles evenly and solvent flows freely from the bleed hose.
- Allow the sprayer to run for 15–30 seconds to flush the test fluid out through the bleed hose and into the waste container.
- Turn off the sprayer.
 - To turn off the gas engine,
 - set the pressure to minimum by turning the pressure control knob fully counterclockwise,
 - move the throttle lever to the slow position, and
 - turn the engine switch to the OFF position.
 - To turn off the electric motor,
 - set the pressure to minimum by turning the pressure control knob fully counterclockwise,
 - move the ON/OFF switch to the OFF position.

NOTE: Make sure that the spray gun does not have a tip or tip guard installed.

10. Close the bleed valve by turning it fully clockwise.
11. Start the engine or turn on the electric motor.
12. Turn the pressure control knob clockwise approximately 1/3 of the way down to increase pressure.
13. Unlock the gun by turning the gun trigger lock to the unlocked position.

WARNING

Ground the gun by holding it against the edge of the metal container while flushing. Failure to do so may lead to a static electric discharge, which may cause a fire.



14. Trigger the gun into the metal waste container until the old solvent is gone and fresh solvent is coming out of the gun.
15. Lock the gun by turning the gun trigger lock to the locked position.
16. Set down the gun and increase the pressure by turning the pressure control knob slowly clockwise.
17. Check the entire system for leaks. If leaks occur, follow the "Pressure Relief Procedure" in this manual before tightening any fittings or hoses.
18. Follow the "Pressure Relief Procedure" in this manual before changing from solvent to paint.

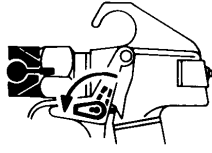

Trigger lock in locked position.

WARNING

Be sure to follow the pressure relief procedure when shutting the sprayer down for any purpose, including servicing or adjusting any part of the spray system, changing or cleaning spray tips, or preparing for cleanup.

Painting

1. Place the siphon hose into a container of paint.
2. Place the bleed hose into a metal waste container.
3. Set the pressure to minimum by turning the pressure control knob fully counterclockwise.

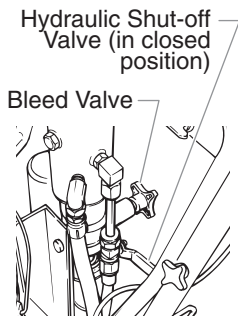

Hydraulic Shut-off Valve (in closed position)

Bleed Valve

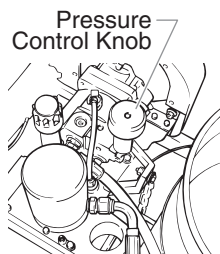

Pressure Control Knob

4. Open the hydraulic shut-off valve located on the hydraulic pressure hose. The handle should be in line with the hose.
5. Open the bleed valve by turning it fully counterclockwise.

6. Start the engine or turn on the electric motor.
 - a. To start the gas engine,
 - move the fuel valve lever to the open position,
 - move the throttle lever to its middle point,
 - move the choke lever to the closed position for a cold engine or to the open position for a warm engine,
 - turn the engine switch to the ON position, and
 - pull the starter rope briskly until the engine starts.
 - b. To start the electric motor, move the ON/OFF switch to the ON position.

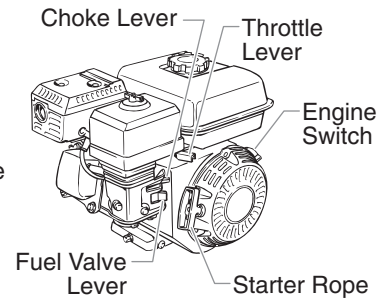

7. Turn the pressure control knob clockwise approximately 1/3 of the way down to increase pressure until the sprayer cycles evenly and paint flows freely from the bleed hose.
8. Turn off the sprayer.
 - a. To turn off the gas engine,
 - set the pressure to minimum by turning the pressure control knob fully counterclockwise,
 - move the throttle lever to the slow position, and
 - turn the engine switch to the OFF position.
 - b. To turn off the electric motor,
 - set the pressure to minimum by turning the pressure control knob fully counterclockwise,
 - move the ON/OFF switch to the OFF position.
9. Remove the bleed hose from the waste container and place it into the container of paint.
10. Close the bleed valve by turning it fully clockwise.
11. Start the engine or turn on the electric motor.
12. Turn the pressure control knob clockwise approximately 1/3 of the way down to increase pressure.
13. Unlock the gun by turning the gun trigger lock to the unlocked position.

WARNING

Ground the gun by holding it against the edge of the metal container while flushing. Failure to do so may lead to a static electric discharge, which may cause a fire.



14. Trigger the gun into the metal waste container until all air and solvent is flushed from the spray hose and paint is flowing freely from the gun.
15. Lock the gun by turning the gun trigger lock to the locked position.
16. Turn off the sprayer.
17. Attach tip guard and tip to the gun as instructed by the tip guard or tip manuals.

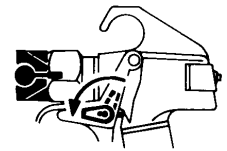

Trigger lock in locked position.

WARNING

POSSIBLE INJECTION HAZARD. Do not spray without the tip guard in place. Never trigger the gun unless the tip is in either the spray or the unclog position. Always engage the gun trigger lock before removing, replacing or cleaning tip.

18. Start the engine or turn on the electric motor.
19. Increase the pressure by turning the pressure control knob slowly clockwise and test the spray pattern on a piece of cardboard. Adjust the pressure control knob until the spray from the gun is completely atomized.

NOTE: Turning the pressure up higher than needed to atomize the paint will cause premature tip wear and additional overspray.

Operating the Front Caster

The front caster on the cart is designed to track the sprayer in either a straight line or allow free motion. Standing behind the sprayer, the trigger on the left handle of the cart controls the operation of the front caster.

1. To lock the front caster in the straight line position, squeeze then release the caster trigger and move the sprayer forward.
2. To allow free motion of the front caster, squeeze and hold the caster trigger.

Pressure Relief Procedure

WARNING

Be sure to follow the pressure relief procedure when shutting the sprayer down for any purpose, including servicing or adjusting any part of the spray system, changing or cleaning spray tips, or preparing for cleanup.

1. Lock the spray gun by turning the gun trigger lock to the locked position.
2. Turn off the sprayer.
 - a. To turn off the gas engine,
 - set the pressure to minimum by turning the pressure control knob fully counterclockwise,
 - move the throttle lever to the slow position, and
 - turn the engine switch to the OFF position.
 - b. To turn off the electric motor,
 - set the pressure to minimum by turning the pressure control knob fully counterclockwise,
 - move the ON/OFF switch to the OFF position.
3. Close the hydraulic shut-off valve on the hydraulic pressure hose.
4. Unlock the gun by turning the gun trigger lock to the unlocked position.
5. Hold the metal part of the gun firmly to the side of a metal waste container to ground the gun and avoid a build up of static electricity.
6. Trigger the gun to remove any pressure that may still be in the hose.
7. Lock the gun by turning the gun trigger lock to the locked position.
8. Place the bleed hose into the metal waste container.
9. Open the bleed valve by turning it fully counterclockwise.



Trigger lock in locked position.



Cleanup

WARNING

Special cleanup instructions for use with flammable solvents:

- Always flush spray gun preferably outside and at least one hose length from spray pump.
- If collecting flushed solvents in a one gallon metal container, place it into an empty five gallon container, then flush solvents.
- Area must be free of flammable vapors.
- Follow all cleanup instructions.

CAUTION

The sprayer, hose, and gun should be cleaned thoroughly after daily use. Failure to do so permits material to build up, seriously affecting the performance of the sprayer.

WARNING

Always spray at minimum pressure with the gun nozzle tip removed when using mineral spirits or any other solvent to clean the sprayer, hose, or gun. Static electricity buildup may result in a fire or explosion in the presence of flammable vapors.

1. Follow the "Pressure Relief Procedure" found in the Operation section of this manual.
2. Remove the gun tip and tip guard and clean with a brush using the appropriate solvent.
3. Place the siphon tube into a container of the appropriate solvent.

CAUTION

Use only compatible solvents when cleaning out oil based enamels, lacquers, coal tar, and epoxies. Check with the fluid manufacturer for the recommended solvent.

4. Place the bleed hose into a metal waste container.
5. Set the pressure to minimum by turning the pressure control knob fully counterclockwise.

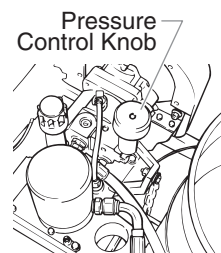
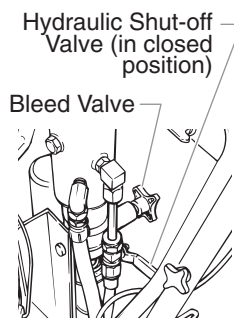

6. Open the hydraulic shut-off valve located on the hydraulic pressure hose. The handle should be in line with the hose.
7. Open the bleed valve by turning it fully counterclockwise.
8. Start the engine or turn on the electric motor.
9. Allow the solvent to circulate through the sprayer and flush the paint out of the bleed hose into the metal waste container.
10. Turn off the sprayer.
11. Close the bleed valve by turning it fully clockwise.
12. Start the engine or turn on the electric motor.

⚠ WARNING

Ground the gun by holding it against the edge of the metal container while flushing. Failure to do so may lead to a static electric discharge, which may cause a fire.

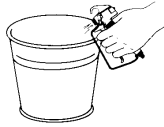

13. Trigger the gun into the metal waste container until the paint is flushed out of the hose and solvent is coming out of the gun.
14. Continue to trigger the spray gun into the waste container until the solvent coming out of the gun is clean.

NOTE: For long-term or cold weather storage, pump mineral sprits through the entire system.

15. Follow the "Pressure Relief Procedure" found in the Operation section of this manual.
16. Store the sprayer in a clean, dry area.

⚠ CAUTION

Do not store the sprayer under pressure.

Cleaning a Clogged Tip

1. Follow the "Pressure Relief Procedure" in the Operation section of this manual.
2. If the tip clogs, rotate the tip handle 180° until the arrow on the handle is facing the opposite of the spray direction and the handle clicks in the reverse position.
3. Trigger the gun once so that the pressure can blow the clog out. NEVER use the tip in the reverse position for more than ONE trigger pull at a time. This procedure can be repeated until the tip is free of clogging.

⚠ WARNING

The flow from the spray tip is at very high pressure. Contact with any body part may be dangerous. Do not place finger on gun outlet. Do not point the gun at any person. Never operate the spray gun without the proper tip guard.

Maintenance

⚠ WARNING

Before proceeding, follow the Pressure Relief Procedure outlined previously in this manual. Additionally, follow all other warnings to reduce the risk of an injection injury, injury from moving parts or electric shock. Always unplug the sprayer before servicing!

Daily Maintenance

Two daily procedures are required for routine operator maintenance on this sprayer:

1. Lubricating the upper packings.
2. Cleaning the rock catcher.

Lubricating the Upper Packings

1. Clean out the paint that has seeped past the upper packings into the oil cup above the fluid section.
2. Fill the oil cup 1/2 full with Piston Lube (P/N 700-925) supplied by the factory. This will extend packing life.

NOTE: Do not over-fill the oil cup so that it overflows and drips into the paint.



Cleaning the Rock Catcher

1. The rock catcher will clog and must be cleaned at least once a day.
2. Loosen the nut that secures the rock catcher to the siphon tube.
3. Remove the rock catcher from the bottom of the siphon tube.
4. Clean thoroughly with the appropriate solvent.

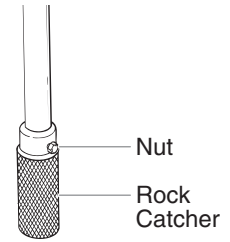

Maintaining the Filter Assembly

Clean the filter regularly. Dirty or clogged filters can greatly reduce filtering ability and cause a number of system problems including poor spray patterns, clogged spray tips, etc.

Cleaning

To clean the filter, perform the following procedure.

1. Follow the "Pressure Relief Procedure" found in the Operation section of this manual.
2. Remove the filter cap assembly and spring.
3. Pull the filter element with ball straight out of the filter body.
4. Clean inside the filter body, filter element with ball, and filter cap assembly using the appropriate solvent.

NOTE: Use care in handling parts as dirt, debris, scratches, or nicks may prevent o-rings or gaskets from sealing.

This filter element filters from the inside out. Be sure to clean the filter element thoroughly on the inside. Soak in solvent to loosen hardened paint or replace.

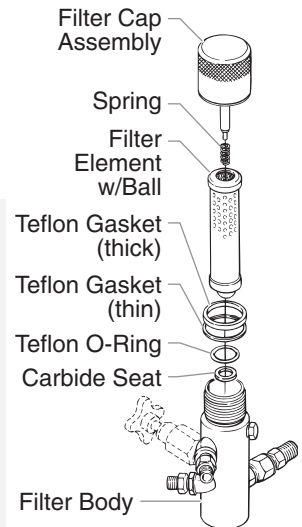

Inspection

Inspect all parts of the filter assembly before reassembly.

1. Inspect the ball inside the filter element. If the ball has pressure cuts or scratches, replace the filter element.
 - a. If the ball is cut, remove the Teflon o-ring using an o-ring pick and remove the carbide seat.
 - b. Check the seat for nicks or grooves. If the seat is damaged, replace.

NOTE: Removal of the Teflon o-ring will damage the o-ring and require replacement.

2. Remove the spring from the spring guide on the filter cap.
 - a. Measure the length of the spring uncompressed. If it measures less the 3/4" from end to end, replace.
 - b. Push the spring back onto the spring guide until it "snaps" back into position.
3. Inspect the two Teflon gaskets and the Teflon o-ring for deformity, nicks, or cuts. Replace, if needed.

NOTE: The Teflon gaskets, Teflon o-ring, and spring are packaged in Filter Service Kit P/N 930-050.

Reassembly

After cleaning and inspecting all parts, reassemble the filter.

1. Place the carbide seat into the filter body. Make sure the beveled side of the seat is facing up.
2. Place the Teflon o-ring into the groove on the outer diameter of the carbide seat.
3. Place the filter element with ball into the filter body.

NOTE: The top and bottom of the filter element with ball are identical.

4. Push the spring back onto the spring guide of the filter cap until it "snaps" back into position, if not already done.
5. Place the thin Teflon gasket onto the step at the top of the filter body.
6. Place the thick Teflon gasket onto the top of the thin gasket.
7. Tighten the filter cap assembly onto the filter body.

Maintaining the Hydraulic System

CAUTION

Use of Speeflo's Coolflo™ Hydraulic Fluid is mandatory in the hydraulic system. Do not use any other hydraulic fluid. Use of any other hydraulic fluid may seriously damage the hydraulic system and will void the warranty.

1. Check the hydraulic fluid daily. It should be at the "Full" mark on the dipstick. If it is low, add only Speeflo Coolflo™ Hydraulic Fluid (P/N 430-361). Never add or change hydraulic fluid except in a clean, dust-free area. Contamination of the hydraulic fluid will shorten hydraulic pump life and may void warranty.

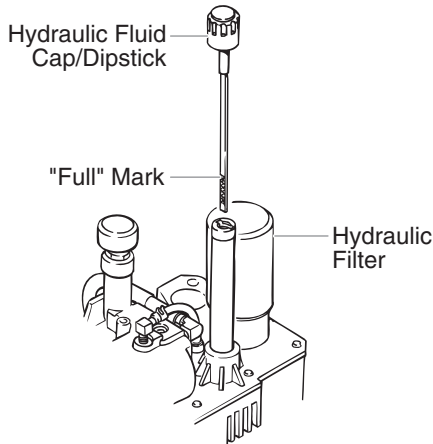

2. Change the hydraulic fluid every twelve months. Drain the old fluid from the tank and fill with 5 quarts of Speeflo Coolflo™ Hydraulic Fluid. Start the sprayer at just enough pressure to operate the fluid section. Run the sprayer at this low pressure for at least 5 minutes. This removes air from the system. Check the fluid level after this procedure.
3. The hydraulic system has an external, replaceable hydraulic filter. Change the filter every twelve months.
4. The hydraulic pump should not be serviced in the field. If service on the hydraulic pump is required, it must be returned to Speeflo.

Maintaining the Fluid Section

If the sprayer is going to be out of service for an extended period of time, it is recommended that following cleanup, a kerosene and oil mixture be introduced as a preservative. Packings may tend to dry out from lack of use. This is particularly true of the upper packing set for which upper packing lubricant Piston Lube (P/N 700-925) is recommended in normal usage.

If the sprayer has been out of service for an extended period of time, it may be necessary to prime the suction by pouring some of the paint solvent into the siphon tube to restart. It is extremely important that the threads on the siphon hose coupling are properly sealed. Any air leakage will produce erratic operation of the sprayer and may damage the system. The up and the down strokes should be approximately equal in time (one should not be faster than the other). A fast up or down stroke may indicate air in the system or malfunctioning valve or seats (see the Troubleshooting section).

Basic Engine Maintenance (gas engine)

- For detailed engine maintenance and technical specifications refer to the separate gasoline engine manual.
- All service to the engine should be performed by an authorized Honda Power Equipment dealer. To locate a dealer in your area, look in the Yellow Pages of your telephone directory under Gasoline Engines, Garden & Lawn Equipment & Supplies, Lawn Mowers, etc.
- The Honda engine is warranted exclusively by American Honda Motor Co., Inc.
- Use a premium quality motor oil certified to meet or exceed U.S. Automotive requirement SG or SF. SAE 10W30 is recommended for general all temperature use. Other viscosities may be required in other climates.
- Use only a (NGK) BP6ES or BPR6E spark plug. Gap the plug to 0.028 to 0.031 in. (0.7 to 0.8 mm) Always use a spark plug wrench.

Daily

1. Check engine oil level, and fill as necessary.
2. Check gasoline level, and fill as necessary.

WARNING

Always follow the fueling procedure outlined earlier in this manual.

First 20 Hours

1. Change engine oil.

Every 100 Hours

1. Change engine oil.
2. Clean the sediment cup.
3. Clean and re-gap the spark plug.
4. Clean the spark arrestor.

Weekly

1. Remove the air filter cover and clean the element. In very dusty environments, check the filter daily. Replace the element as needed. Replacement elements can be purchased from your local Honda dealer.

Engine Operation and Service

1. Clean and oil air filter pad on gasoline engine every 25 hours or once weekly. Do not permit the air intake screen around the fly wheel of the gas engine to load up with paint or trash. Clean it regularly. The service life and efficiency of the gas engine model depends upon keeping the gasoline engine running properly. Change the oil in the engine every 100 hours. Failure to observe this may result in engine overheating. Consult the engine manufacturer's service manual provided.
2. To conserve fuel, service life, and efficiency of the sprayer, always operate the gasoline engine at the lowest RPM at which it runs smoothly without laboring and delivers the amount required for the particular painting operation. Higher RPM does not produce higher working pressure. The gasoline engine is connected to the hydraulic pump by a pulley combination designed to produce full paint delivery at maximum RPM.
3. The warranty on gasoline engines or electric motors is limited to the original manufacturer.

Replacing the Motor Brushes (electric motor)

Perform this procedure using Motor Brush Kit P/N 978-050. The kit consists of two brushes, two springs, and two clips.

NOTE: Brushes should be replaced when they are worn to less than 1/2 inch. Check and replace both brushes at the same time.

1. Remove both inspection covers on the motor.

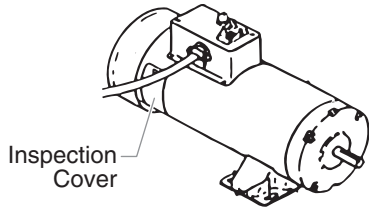

2. Push in the spring clip to unhook it, then pull it out..

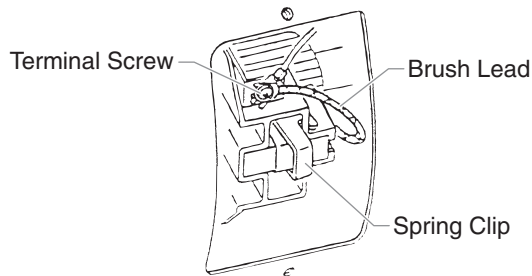

3. Loosen the terminal screw. Pull the brush lead away, but leave the motor lead in place. Remove the brush and spring.
4. Inspect the commutator for burning, excessive pitting or gouging. A black color on the commutator is normal.

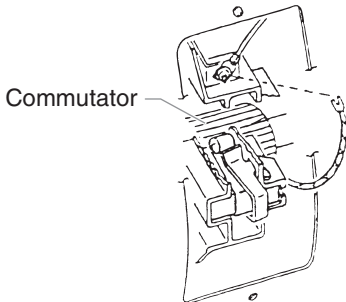

5. Install the new brush so its lead slides in the long slot of the brush holder. Push the terminal under the terminal screw washer. Ensure the motor lead is still connected at the screw. Tighten the screw.

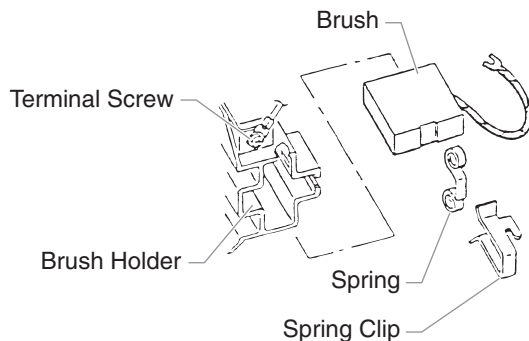

6. Place the spring on the brush as shown above. Push in and hook the spring clip. Repeat this procedure for the other side.
7. Reinstall both inspection covers.

WARNING

If electric motor overloads and stops running, **IMMEDIATELY** turn the motor off and follow the Pressure Relief Procedure in the Cleanup section of this manual. Wait until the motor cools (approximately 30 minutes). Then push in the bubble top, manual reset button, turn the motor on and pressurize the system.

For CSA approved sprayers only: The ON/OFF switch is also the RESET!

Adjusting the Tracking of the Front Caster

The front caster is set by the factory to track in a straight line. Use the following procedure if adjustment the caster becomes necessary.

1. Loosen the two hex screws in the top of the caster mounting bracket.
2. Turn the caster mounting bracket slightly in the desired direction.

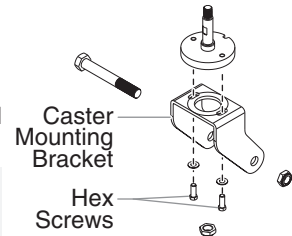

NOTE: The front caster locking pin must be engaged during tracking adjustment.

3. Tighten the two hex screws.
4. Check the tracking of the front caster. If the caster does not track straight, repeat the above procedure.

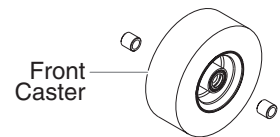

Troubleshooting

Airless Gun

Problem

Spitting gun

Cause

1. Air in system
2. Dirty gun
3. Needle assembly out of adjustment
4. Broken or chipped seat

Solution

1. Inspect connections for air leaks.
2. Disassemble and clean.
3. Inspect and adjust.
4. Inspect and replace.

Gun will not shut off

1. Worn or broken needle & seat
2. Needle assembly out of adjustment
3. Dirty gun

1. Replace.
2. Adjust.
3. Clean.

Gun does not spray

1. No paint
2. Plugged filter or tip
3. Broken needle in gun

1. Check fluid supply.
2. Clean.
3. Replace.

Fluid Section

Problem

Pump delivers on upstroke only or goes up slowly and down fast (commonly called downstroke dive)

Cause

1. Lower foot valve ball is not seating due to trash or wear
2. Material too viscous to siphon.
3. Air leaking in on siphon side or damaged siphon hose. Siphon may be too small for heavy material.

Solution

1. Remove foot valve assembly. Clean and inspect. Test foot valve by filling with water; if ball fails to seal the seat, replace ball.
2. Thin material — contact manufacturer for proper thinning procedures.
3. Tighten all connections between pump and paint container. If damaged, replace. Switch to larger diameter siphon set.

Pump delivers on down stroke only or goes up fast and down slowly

1. Upper ball is not seating due to trash or wear
2. Lower packing set is worn

1. Check upper seat and ball with water. If ball fails to seal, replace seat.
2. Replace packing set if worn.

Pump moves up and down fast, delivering material

1. Material container is empty or material is too thick to flow through siphon hose
2. Bottom ball stuck to foot valve seat
3. Siphon hose is kinked or loose

1. Refill with new material. If too thick, remove siphon hose, immerse fluid section in material, and start pump to prime. Add thinner to material. Change to bigger siphon set. Open bleed valve to remove air and restart pump.
2. Remove foot valve. Clean ball and seat.
3. Straighten.

Pump moves up and down slowly when spray gun is shut off

1. Loose connections. Bleed valve is open partially or bleed valve is worn. Lower packing seat is worn.
2. Upper and/or lower ball not seating

1. Check all connections between pump and gun. Tighten as necessary. If material is flowing from bleed hose, close bleed valve or replace, if necessary. Should none of the above be evident, replace lower packing.
2. Reseat balls by cleaning.

Not enough fluid pressure at gun

1. Spray tip is worn
2. Outlet filter or gun filter is clogged
3. Low voltage and/or inadequate amperage
4. Hose size or length is too small or too long

1. Replace.
2. Clean or replace filter.
3. Check electrical service. Correct as required.
4. Increase hose size to minimize pressure drop through hose and/or reduce hose length.

Pump chatters on up or down stroke

1. Solvent has caused upper packing to swell

1. Replace packing.

Troubleshooting

Hydraulic Motors

Problem

Oil motor stalls at bottom (no unusual heat problems)

Cause

1. Fluid pump piston seat unthreaded
2. Valve sticking or oil motor trip rod shifter assembly separated

Oil motor stalls at top (no unusual heat problems)

1. Valve sticking
2. Broken spring retainer (valve rod assembly)
3. Broken spring or valve rod
4. Air in hydraulic motor

5. Air in fluid pump

Low pressure (okay on down stroke, sluggish on up.stroke — high heat)

NOTE: Engine labors on upstroke, idles back at stall on the down stroke.

1. Blown piston seal
2. Cracked piston

Low pressure (both strokes - high heat)

NOTE: Engine labors at stall on both strokes.

1. Blown center o-rings on spool valve
2. Bad hydraulic pump

Solution

1. If connecting rod is okay, remove cylinder head plug and pop valve down. Replace plug and start machine. If machine cycles up and stops at bottom again, then problem is piston seat on fluid pump. Check piston seat. Repair or replace as necessary. If piston seat is okay and problem does not change, check oil motor.
2. Remove valve and check for scratches and rough movement when sliding it up and down. Replace valve and spool in this condition. Check trip rod for possible separation.and spool in this condition. Check trip rod for possible separation.

1. Remove valve and check for scratches and rough movement when sliding it up and down. Replace valve and spool in this condition.
2. Replace valve rod assembly.
3. Replace valve rod assembly.
4. Reset valve. Purge Air, generally accomplished by low pressure cycling of motor/pump assembly for 5–10 minutes. Check for causes of air introduction:
 - Loose fittings in tank.
 - Loose fittings on hydraulic pump.
 - Loose hose connections.
 - Low oil in reservoir.
5. Stall at top can occur randomly when fluid pump picks up air. Reset valve. Avoid air in the fluid pump.

1. Before dismantling oil motor, start machine. With pump cycling under pressure, touch the hydraulic cylinder and the head to see if cylinder or head gets hotter. This will help determine if piston seal is blown or piston nut is broken. If heat is on the head, check the o-rings on spool valve.
2. Dismantle oil motor and check piston seals cylinder bore and piston nut. Pay special attention to piston nut. It can be cracked and not show externally.

1. Before dismantling oil motor, start machine. With pump cycling under pressure, touch the head to see if the head becomes hotter. This will help determine if center o-ring is blown on spool valve. If hot, remove and replace o-ring.
2. Replace hydraulic pump.

Troubleshooting

Spray Patterns

Problem

Tails

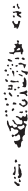

Cause

1. Inadequate fluid delivery

Solution

1. Fluid not atomizing correctly:
Increase fluid pressure. Change to smaller tip orifice size. Reduce fluid viscosity. Reduce hose length. Clean gun and filter(s). Reduce number of guns using pump.

Hour glass

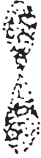

1. Inadequate fluid delivery

1. Same as above.

Distorted



1. Plugged or worn nozzle tip

1. Clean or replace nozzle tip.

Pattern expanding and contracting (surge)



1. Suction leak
2. Pulsating fluid delivery

1. Inspect for suction hose leak.
2. Change to a smaller tip orifice size. Install pulsation dampener in system or drain existing one. Reduce number of guns using pump. Remove restrictions in system; clean tip screen if filter is used.

Round pattern



1. Worn tip
2. Fluid too heavy for tip

1. Replace tip.
2. Increase pressure. Thin material. Change nozzle tip.

Sécurité

Le présent manuel comprend des renseignements devant être lus attentivement avant toute utilisation de l'appareil. Lorsque l'un des symboles suivants apparaît, il est recommandé d'être particulièrement attentif et de tenir compte des mesures de sécurité indiquées.

⚠ AVERTISSEMENT

Ce symbole indique un danger potentiel pouvant causer des blessures graves ou même mortelles. Des renseignements importants sur la sécurité sont également indiqués.

⚠ ATTENTION

Ce symbole indique un danger potentiel pouvant causer des blessures corporelles ou des dommages à l'équipement. Des renseignements importants sur la façon de prévenir tout dommage à l'équipement ou toute blessure corporelle mineure sont également indiqués.

NOTA : Les remarques donnent des renseignements importants requérant une attention particulière.

⚠ AVERTISSEMENT

DANGER: BLESSURES PAR PERFORATION - Le jet de peinture à haute pression produit par cet appareil peut perforer la peau et les tissus sous-jacents et entraîner de sévères blessures pouvant nécessiter une amputation. Consultez immédiatement un médecin.

NE PAS TRAITER UNE BLESSURE PAR PERFORATION COMME UNE SIMPLE COUPURE! Une perforation peut entraîner des risques d'amputation. Consultez immédiatement un médecin.

Pression de service maximale du fluide dans l'appareil : 3300 lb/po2 / 22.8 MPa.

MESURES PRÉVENTIVES:

- NE JAMAIS diriger le pistolet vers une quelconque partie du corps.
- NE JAMAIS mettre une quelconque partie du corps en contact avec le jet de liquide. NE JAMAIS se mettre au contact d'un jet de liquide provenant d'une fuite du flexible d'alimentation en liquide.
- NE JAMAIS placer votre main devant le pistolet. Des gants ne vous protégeront pas contre les risques de blessures par perforation.
- TOUJOURS verrouiller la gâchette du pistolet, fermer la pompe à liquide et décompresser l'appareil lorsque vous travaillez sur celui-ci, nettoyez le protecteur de tête, remplacez la tête de pulvérisation ou vous éloignez de l'appareil. Couper le moteur ne décompresse pas l'appareil. Vous devez, pour le décompresser, placer le bouton AMORÇAGE/PULVÉRISATION en position AMORÇAGE. Reportez-vous, pour cela, à la PROCÉDURE DE DÉCOMPRESSION décrite dans de ce manuel.
- TOUJOURS s'assurer que le protecteur de tête est en place lorsque vous pulvérisez. Le protecteur de tête offre une certaine protection contre les blessures par perforation mais sa principale fonction est d'ordre préventif.
- TOUJOURS ôter la tête de pulvérisation avant de purger ou nettoyer l'appareil.
- Le flexible d'alimentation en peinture peut fuir à la suite d'une usure, de chocs ou de mauvais traitements. Une fuite peut entraîner une perforation de la peau. Inspecter le flexible avant chaque utilisation.
- NE JAMAIS utiliser un pistolet dont la gâchette n'est pas munie d'un loquet ou un cran de sécurité qui soit en état de fonctionner.
- Tous les accessoires doivent être homologués pour une pression égale ou supérieure à 3 300 lb/po2 / 22.8 MPa. Cela s'applique, entre autres, aux têtes de pulvérisation, aux accessoires du pistolet et aux flexibles.

AVERTISSEMENT AUX MÉDECINS : Une perforation sous-cutanée constitue un traumatisme. Il est important de traiter la blessure de façon chirurgicale aussitôt que possible. NE RETARDEZ PAS ce traitement pour des recherches de toxicité. La toxicité n'est un risque que dans les cas où certains produits de revêtement pénètrent dans le flux sanguin. Il peut être nécessaire de faire appel à des soins de chirurgie plastique ou de reconstruction de la main.

DANGER: RISQUES D'EXPLOSION OU D'INCENDIE - Les vapeurs dégagées par le solvant ou la peinture sont explosives et inflammables et peuvent causer des corporels sérieux ou dommages matériels.

MESURES PRÉVENTIVES:

- Veiller à éviter toute accumulation de vapeurs inflammables en vous assurant que la zone où la pulvérisation a lieu est suffisamment ventilée.
- Veiller à éviter la présence de toute source incandescente telle qu'étincelle électrostatique, flamme nue, flamme-pilote, objet brûlant, cigarette et étincelle provenant du branchement ou du débranchement d'un cordon d'alimentation électrique ou d'un commutateur.
- Ne pas fumer dans la zone d'épandage.
- Toujours avoir un extincteur en état de fonctionner à portée de la main.
- Placer la pompe à peinture dans une zone bien aérée. Les vapeurs inflammables sont souvent plus lourdes que l'air. Le plancher doit être extrêmement bien aéré. La pompe à peinture contient des pièces pouvant créer des étincelles et enflammer les vapeurs présentes dans l'air.
- Le matériel utilisé, ainsi que les objets se trouvant à proximité de la zone de pulvérisation, doivent être convenablement reliés à la terre afin d'éviter toute étincelle ou toute décharge électrostatique.
- N'utiliser que des flexibles d'alimentation en liquide à haute pression conducteurs ou reliés à la terre dans les cas d'utilisation sans air comprimé. S'assurer que le pistolet est convenablement relié à la terre par l'intermédiaire du flexible.
- Le cordon d'alimentation doit être raccordé à un circuit mis à la terre (les modèles électriques seulement).
- Toujours purger l'appareil dans un contenant métallique séparé, en s'assurant que la pompe soit à basse pression et que le chapeau soit retiré. Tenir le pistolet fermement contre la paroi du contenant pour mettre celui-ci à la terre et empêcher l'émission d'étincelles causées par l'électricité statique.
- Se conformer aux consignes et recommandations de sécurité du fabricant du solvant ou du produit.
- S'entourer de toutes les précautions possibles lorsqu'on utilise des produits ayant un point d'éclair inférieur à 21 °C (70 °F). Le point d'éclair d'un fluide est la température à laquelle les vapeurs émanant du fluide peuvent s'enflammer au contact d'une flamme ou d'une étincelle.
- Le plastique peut être une source d'étincelles provoquées par l'électricité statique. Ne jamais utiliser une couverture en plastique pour fermer une zone d'épandage ni utiliser des toiles de protection en plastique lors de la pulvérisation de matières inflammables.
- Lorsque vous purgez l'appareil, veillez à utiliser à la pression minimale.

MOTEUR À ESSENCE (DANS LES CAS OÙ CELA S'APPLIQUE)

Toujours placer la pompe à l'extérieur de la structure à l'air frais. Garder tous les solvants loin de l'échappement du moteur. Ne jamais remplir le réservoir à carburant lorsque le moteur est en marche ou lorsqu'il est chaud ; les surfaces chaudes risquent d'enflammer le carburant déversé accidentellement. Toujours raccorder un fil de mise à la terre entre la pompe et un objet mis à la terre, tel qu'une conduite d'eau métallique. Se reporter au guide d'utilisation du moteur pour obtenir de plus amples renseignements concernant la sécurité.

DANGER: RISQUES D'EXPLOSION PAR INCOMPATIBILITÉ DES MATÉRIAUX - Peuvent être à l'origine de corporels sérieux ou dommages matériels.

MESURES PRÉVENTIVES:

- Ne pas utiliser de matériaux contenant des agents de blanchiment ou du chlore.
- Ne pas utiliser des solvants à base d'hydrocarbure halogéné tels que l'agent anticryptogamique, le chlorure de méthylène et le trichloro-éthane-1,1,1. Ces produits ne sont pas compatibles avec l'aluminium.
- Communiquer avec votre fournisseur de revêtement pour connaître la compatibilité du matériau avec l'aluminium.

DANGER: VAPEURS NOCIVES – la peinture, les solvants, les insecticides et autres matériaux peuvent être nocifs lorsqu'ils sont inhalés ou en contact avec le corps. Les vapeurs peuvent causer une nausée importante, des évanouissements ou un empoisonnement.

MESURES PRÉVENTIVES:

- Utiliser un respirateur ou un masque chaque fois qu'il y a des risques d'inhalation de vapeurs. Lire attentivement toutes les instructions se rapportant au masque pour vérifier que celui-ci vous assure une protection suffisante contre les vapeurs toxiques.
- Porter des lunettes de protection.
- Porter des vêtements de protection, conformément aux directives du fabricant de revêtement.

DANGER: GÉNÉRALITÉS - Peut causer des dommages matériels ou corporels sérieux.

MESURES PRÉVENTIVES:

- Avant d'utiliser tout équipement, lire attentivement toutes les instructions et les consignes de sécurité
- Toujours débrancher le moteur de l'alimentation électrique avant d'effectuer des travaux sur l'appareil (les modèles électriques seulement).
- Se conformer à la législation locale, provinciale ou fédérale pour tout ce qui concerne la ventilation, la prévention des incendies et les conditions générales d'utilisation.
- Les normes de sécurité du Gouvernement américain sont régies par le Occupational Safety and Health Act (OSHA). Il est important de consulter ces normes, en particulier la section 1910 sur les normes générales et la section 1926 sur les des normes de la construction.
- N'utiliser que les pièces autorisées par le fabricant. L'utilisateur assume tous les risques et responsabilités lorsqu'il utilise des pièces qui ne sont pas conformes aux caractéristiques techniques minimales ainsi qu'aux dispositifs de sécurité du fabricant de la pompe.
- Vérifier, avant toute utilisation, que les flexibles ne présentent pas d'entaille ou de fuite, que le couvercle ne soit pas gonflé et que les raccords ne soient pas endommagés. Si le flexible a subi l'un des dommages précités, remplacez-le immédiatement. Ne jamais réparer un flexible d'alimentation en peinture. Le remplacer par un autre flexible mis à la terre.
- Tout flexible, raccord orientable, pistolet et accessoire utilisé avec cet appareil doit pouvoir fonctionner à une pression égale ou supérieure à 3 300 lb/po² / 22.8 MPa.
- Ne jamais pulvériser lorsqu'il vente.
- Porter des vêtements pour protéger la peau et les cheveux contre tout contact avec la peinture.

Instructions de mise à la terre

Les modèles électriques doivent être mis à la terre. La mise à la terre réduit les risques d'électrocution lors d'un court-circuit en permettant au courant de s'écouler par le fil de mise à la terre. Cet appareil est muni d'un cordon électrique avec fil de mise à la terre ainsi que d'une fiche de terre. La fiche doit être branchée sur une prise installée correctement et mise à la terre conformément à la réglementation et aux codes en vigueur.

DANGER — Une prise de terre mal branchée peut être à l'origine d'électrocutions. S'il s'avère nécessaire de réparer ou de remplacer le cordon électrique ou la fiche, ne pas brancher le fil vert de mise à la terre sur l'une ou l'autre des bornes à broche plate. Le fil recouvert d'un isolant vert avec ou sans rayures jaunes est le fil de mise à la terre et doit être branché sur la broche de mise à la terre.

Si vous ne comprenez pas les instructions de mise à la terre ou si vous n'êtes pas sûr que l'appareil est correctement mis à la terre, contactez un électricien agréé. Ne pas modifier la fiche d'origine. Si la prise ne convient pas à la fiche, faites installer la prise adéquate par un électricien agréé.

Ce produit a une intensité nominale de plus de 15 ampères et doit être utilisé sur un circuit de 120 volts ou plus. Il doit en outre être muni de l'usure d'un cordon électrique et d'une fiche spécifiques permettant son raccordement à un circuit électrique approprié. S'assurer que le produit soit branché sur une prise ayant la même configuration que la fiche. Ne pas utiliser d'adaptateur avec ce produit. Si le produit doit être branché à nouveau pour être utilisé sur un circuit électrique de type différent, le raccordement doit être effectué par un personnel de service qualifié.



Utiliser uniquement une rallonge à trois fils munie d'une fiche de terre dans une prise secteur mise à la terre correspondant au type de fiche de l'appareil. S'assurer que votre rallonge est en bon état. Lorsque vous utilisez une rallonge, assurez-vous qu'elle soit d'un calibre suffisant pour supporter l'intensité du courant requise par l'appareil. Une rallonge trop mince entraîne une chute de tension, une diminution de l'intensité et une surchauffe. Pour les longueurs inférieures à 15,2 mètres (50 pi), utiliser des rallonges de calibre 12 AWG. Si vous devez utiliser une rallonge à l'extérieur, celle-ci doit comprendre la marque W-A après la désignation indiquant le type de cordon. Par exemple, la désignation SJTW-A indique que le cordon est conçu pour être utilisé à l'extérieur.

Sécurité du moteur à essence



L'État de la Californie reconnaît que les gaz d'échappement de cet appareil contiennent des produits chimiques susceptibles de causer le cancer, des malformations congénitales ou pouvant être nocifs pour le système reproducteur.

1. Les moteurs Honda sont conçus pour être fiables et sécuritaires lorsqu'ils sont utilisés selon les directives. Lire et comprendre le guide d'utilisation de Honda avant de faire fonctionner le moteur. Le non-respect de cet avertissement risque de causer des blessures graves ou d'endommager l'appareil.
2. Afin de prévenir les risques d'incendie et d'assurer une ventilation adéquate, garder le moteur à une distance d'au moins un mètre (3 pi) des bâtiments et des autres appareils durant le fonctionnement. Ne pas placer des objets inflammables près du moteur.
3. Les enfants et les animaux doivent être tenus à l'écart de la zone de fonctionnement de l'appareil afin d'éviter les risques de brûlures causées par les composants chauds du moteur ou par les équipements utilisés avec le moteur.
4. Savoir comment couper le moteur rapidement et bien comprendre le fonctionnement de toutes les commandes. Ne jamais laisser quiconque utiliser le moteur sans lui avoir d'abord fourni les directives appropriées.
5. Le carburant est une matière extrêmement inflammable et peut exploser sous certaines conditions.
6. Ravitailler en carburant dans un endroit bien aéré une fois le moteur arrêté. Ne pas fumer et s'assurer qu'il n'y ait ni flammes ni étincelles dans la zone de ravitaillement ou d'entreposage du carburant.
7. Ne pas trop remplir le réservoir d'essence. Après le ravitaillement, s'assurer que le bouchon du réservoir soit bien fermé et serré.
8. Prendre soin de ne pas renverser de carburant lors du ravitaillement, car les vapeurs émanant du carburant ou le carburant déversé accidentellement peuvent s'enflammer. En cas de déversement, s'assurer que l'endroit soit complètement sec avant de démarrer le moteur.
9. Ne jamais mettre le moteur en marche dans un endroit fermé ou restreint, car les gaz d'échappement contiennent des matières toxiques, telles que le monoxyde de carbone, susceptibles de provoquer des évanouissements ou même d'entraîner la mort.
10. Le silencieux devient très chaud durant le fonctionnement et le demeure pendant un certain temps une fois le moteur arrêté. S'assurer d'attendre quelques minutes avant de toucher au silencieux. Pour éviter les risques de brûlures graves ou d'incendie, laisser le moteur se refroidir avant de le transporter ou de l'entreposer à l'intérieur.
11. Ne jamais expédier ou transporter l'appareil lorsque le réservoir est rempli de carburant.



Ne pas utiliser cet appareil pour vaporiser de l'eau ou de l'acide.



Ne pas soulever par la poignée du chariot lors du chargement ou du déchargement.

Seguridad

Este manual contiene información que debe leer y comprender antes de usar el equipo. Cuando se encuentre con uno de los siguientes símbolos, asegúrese de observar sus indicaciones de seguridad.

⚠️ ADVERTENCIA

Este símbolo indica la existencia de un peligro potencial que puede causar lesiones graves o la muerte. Después del mismo se incluye información de seguridad importante.

⚠️ PRECAUCION

Este símbolo indica la existencia de un peligro potencial para usted o el equipo. Después del mismo se incluye información importante que indica la forma de evitar daños al equipo o la forma de prevenir lesiones menores.

NOTA: los avisos contienen información importante, présteles especial atención.

⚠️ ADVERTENCIA

PELIGRO: LESIÓN POR INYECCIÓN - La corriente de pintura de alta presión que produce este equipo puede perforar la piel y tejidos subyacentes, lo que conduciría a lesiones serias y una posible amputación. Consulte de inmediato a un médico.

NO TRATE LAS LESIONES POR INYECCIÓN COMO SI FUERAN SIMPLES CORTADAS! Una inyección puede conducir a una amputación. Consulte de inmediato a un médico.

El rango de operación máximo de la unidad es 3300 PSI / 22.8 MPa de presión de fluidos.

PARA PREVENIR:

- NO dirija NUNCA la punta de la pistola hacia alguna parte del cuerpo.
- NO permita NUNCA que alguna parte del cuerpo tenga contacto con la corriente del fluido. EVITE tener contacto con corrientes de fluido que salgan de fugas que haya en la manguera.
- NO ponga NUNCA la mano enfrente de la manguera. Los guantes no ofrecen ninguna protección contra lesiones por inyección.
- Bloquee SIEMPRE el gatillo de la pistola, apague la bomba de fluido y libere toda la presión antes de dar mantenimiento, limpiar el protector de la boquilla, cambiar la boquilla o dejar desatendido el equipo. La presión no se liberará al apagar el motor. Para liberar la presión debe girarse la perilla PRIME/SPRAY (cebar/atomizar) hasta la posición PRIME. Consulte el PROCEDIMIENTO PARA LIBERAR LA PRESIÓN que se describe en este manual.
- Mantenga puesto SIEMPRE el protector de la boquilla mientras atome. El protector de la boquilla ofrece cierta protección contra lesiones por inyección pero es principalmente un dispositivo de advertencia.
- Quite SIEMPRE la boquilla del atomizador antes de enjuagar o limpiar el sistema.
- Pueden desarrollarse fugas en la manguera de pintura por causa del desgaste, retorcimientos o el abuso. Una fuga es capaz de inyectar el material en la piel. Cada vez que use la manguera de pintura, inspecciónela antes.
- NO use nunca una pistola de atomización que no tenga un bloqueador o un protector de gatillo puesto y que funcione.
- Todos los accesorios deben tener una capacidad de 3300 lb/pulg² / 22.8 MPa o mayor. Esto incluye las boquillas de atomizador, pistolas, extensiones y mangueras.

NOTA PARA EL MÉDICO: La inyección dentro de la piel es una lesión traumática. Es importante que la lesión se trate quirúrgicamente tan pronto como sea posible. NO retrase el tratamiento por investigar la toxicidad. La toxicidad es motivo de preocupación con algunos revestimientos que se inyectan directamente en la corriente sanguínea. Es recomendable consultar a un cirujano plástico o reconstructor de manos.

PELIGRO: EXPLOSIÓN O INCENDIO - Los vapores de solventes y pintura pueden explotar o incendiarse, causando con esto lesiones severas y/o daños en la propiedad.

PARA PREVENIR:

- Debe proveerse un escape y aire fresco para hacer que el aire que está dentro del área de atomización se mantenga libre de acumulaciones de vapores inflamables.

- Evite todas las fuentes de ignición como son las chispas electrostáticas, llamas abiertas, flamas de piloto, objetos calientes, cigarros, y chispas que se generan al conectar y desconectar las extensiones o de apagadores de luz que estén funcionando.
- No fume en la zona de trabajo.
- Debe haber un equipo para extinguir incendios permanentemente y en buenas condiciones.
- Coloque la bomba para pintar en una zona bien ventilada. Los gases inflamables a menudo son más pesados que el aire. La zona del piso debe tener la debida ventilación. La bomba para pintar contiene piezas que forman arcos que emiten chispas y pueden encender los gases.
- El equipo que se utilice, así como los objetos que estén dentro y alrededor del área de atomización, deben conectarse a tierra de manera apropiada para prevenir las descargas eléctricas y las chispas.
- Use solamente mangueras para fluidos de alta presión, conductoras o conectadas a tierra, para aplicaciones sin aire. Asegúrese de que la pistola esté conectada a tierra de manera apropiada, mediante conexiones de manguera.
- El cable de alimentación debe enchufarse a un circuito aterrado (eléctrico modelo único).
- Siempre enjuague la unidad en un recipiente de metal por separado, con presión baja en la bomba y sin la boquilla. Sostenga la pistola firmemente contra el recipiente para ponerlo a tierra y evitar chispas estáticas.
- Siga las advertencias y avisos de seguridad del fabricante de los materiales y solventes.
- Tenga muchísimo cuidado al usar materiales cuyo punto de ignición sea inferior a 70° F (21° C). El punto de ignición es la temperatura a la cual pueden encenderse los vapores emanados por un fluido al exponerlos a llamas o chispas.
- El plástico puede causar chispas estáticas. Nunca cuelgue plástico en las ventanas ni en las puertas del área donde va a pintar. No utilice plástico para proteger el piso cuando pinte materiales inflamables.
- Cuando enjuague el equipo utilice la presión más baja posible.

MOTOR DE GAS (SEGÚN CORRESPONDA)

Coloque siempre la bomba fuera del edificio, al aire libre. Mantenga todo solvente alejado del escape del motor. Nunca llene el tanque de combustible si el motor está encendido o caliente. La superficie caliente puede encender el combustible derramado. Conecte siempre un conductor de tierra desde la unidad de la bomba a un objeto puesto a tierra, por ejemplo una tubería de agua metálica. Consulte el manual del motor para obtener información completa de seguridad.

PELIGRO: PELIGRO DE EXPLOSIÓN DEBIDO A MATERIALES INCOMPATIBLES - Podría causar lesiones severas o daños en la propiedad.

PARA PREVENIR:

- No utilice materiales que contengan blanqueador o cloro.
- No use solventes con hidrocarburos halogenados, tales como productos para eliminar el moho, cloruro de metileno y 1,1,1 - tricloroetano. Estos no son compatibles con el aluminio.
- Comuníquese con el proveedor del producto para obtener información de compatibilidad con materiales de aluminio.

PELIGRO: GASES PELIGROSOS - Las pinturas, solventes, insecticidas y otros materiales pueden ser perjudiciales si se inhalan o entran en contacto con el cuerpo. Los gases pueden causar náusea, desmayos o envenenamiento graves.

PARA PREVENIR:

- Use una mascarilla respiratoria o careta siempre que exista la posibilidad de que se puedan inhalar vapores. Lea todas las intrusiones que vengan con la careta para estar seguro de que se tendrá la protección necesaria contra la inhalación de vapores dañinos.
- Use gafas protectoras.
- Use ropa de protección, según lo requiera el fabricante del producto.

PELIGRO: GENERAL - Puede causar daños en la propiedad o lesiones severas.

PARA PREVENIR:

- Lea todas las instrucciones y advertencias de seguridad antes de hacer funcionar cualquier equipo.
- Desconecte siempre el motor del suministro eléctrico antes de dar servicio al equipo (eléctrico modelo único).

- Observe todos los códigos locales, estatales y nacionales apropiados que rigen las medidas de ventilación, prevención de incendios y operación.
- Los Estándares de Seguridad del Gobierno de los Estados Unidos se han adoptado bajo el Acta de Seguridad y Salud Ocupacionales (OSHA por sus siglas en inglés). Deben consultarse estos estándares, particularmente la parte 1910 de los Estándares Generales y la parte 1926 de los Estándares de la Construcción.
- Utilice únicamente piezas autorizadas por el fabricante. El usuario asume todos los riesgos y responsabilidades si usa piezas que no cumplen con las especificaciones mínimas y dispositivos de seguridad del fabricante de la bomba.
- Antes de usarla cada vez, revise todas las mangueras para ver que no tengan cortadas, fugas, una cubierta desgastada por abrasión o con abolladuras, así como uniones dañadas o que se hayan movido. Si existiera cualquiera de estas condiciones, reemplace la manguera inmediatamente. No repare nunca una manguera de pintura. Reemplácela con otra manguera conectada a tierra.
- Todas las mangueras, soportes giratorios, pistolas y accesorios que se usen con esta unidad deben tener una capacidad de presión de 3300 lb/pulg2 o mayor.
- No atomice en días con viento.
- Use ropa que evite el contacto de la pintura con la piel y el cabello.

Instrucciones para conectar a tierra

Los modelos eléctricos deben estar conectados a tierra. En caso de que ocurra un corto circuito, la conexión a tierra reduce el riesgo de choque eléctrico al proporcionar un alambre de escape para la corriente eléctrica. Este producto está equipado con un cable que tiene un alambre de conexión a tierra con un enchufe de conexión a tierra apropiado. El enchufe se debe enchufar en una toma de corriente que se haya instalado y conectado a tierra debidamente, de acuerdo con todos los códigos y estatutos locales.

PELIGRO — Una instalación inapropiada del enchufe de conexión a tierra puede dar como resultado el que exista un riesgo de choque eléctrico. Si es necesario reparar o reemplazar el cable o el enchufe, no conecte el alambre de conexión a tierra a ninguno de los terminales de hoja planos. El alambre con aislamiento que tiene la superficie exterior de color verde con franjas amarillas o sin ellas es el alambre de conexión a tierra que debe conectarse al conector de conexión a tierra.

Verifique con un electricista o técnico de servicio calificado si las instrucciones para conectar a tierra no le han quedado completamente claras, o si duda que el producto haya quedado conectado a tierra de manera apropiada. No modifique el enchufe que se proporciona. Si el enchufe no entra en la toma de corriente, pídale a un electricista calificado que instale la toma apropiada.

Este producto tiene una capacidad nominal de más de 15 amperios y es para uso en circuitos con una capacidad nominal de 120 voltios, o bien, el producto es para uso en circuitos con capacidad nominal superior a 120 voltios, y se equipa en la fábrica con un cable eléctrico y enchufe específicos para permitir la conexión a un circuito eléctrico apropiado. Asegúrese de que el producto esté conectado a una toma que tenga la misma configuración que el enchufe. No se debe usar ningún adaptador con este producto. Si es necesario cambiar la conexión de este producto para uso en un circuito eléctrico diferente, la conexión debe ser realizada por personal técnico calificado.

PRECAUCION

Use solamente extensiones trifilares que tengan un enchufe de conexión a tierra de 3 hojas y un receptáculo de triple ranura que acepte el enchufe del producto. Asegúrese de que su extensión esté en buenas condiciones. Cuando use una extensión, asegúrese de usar una que sea lo suficientemente resistente como para soportar la corriente que descargue su producto. Un cable de un tamaño menor causará una caída de voltaje en la línea que dará como resultado una pérdida de energía y un sobrecalentamiento. Para las longitudes de menos de 15 metros se debe usar un cable de extensión de 12 AWG. Si se utiliza un cable de extensión en el exterior, tiene que estar marcado con el sufijo W-A después de la designación del tipo de cable. Por ejemplo, SJTW-A para indicar que el cable es apropiado para uso en exteriores.

Seguridad con los motores de gasolina

ADVERTENCIA

El escape del motor de esta unidad contiene químicos que el Estado de California ha determinado causan cáncer, defectos de nacimiento u otros daños al sistema reproductor.

1. Los motores Honda están diseñados para proporcionar un servicio seguro y fiable, si se utilizan de acuerdo a las instrucciones. Lea y entienda las instrucciones del Manual del Propietario de Honda antes de utilizar el motor. De lo contrario, podría causar lesiones personales o daño al equipo.
2. Para evitar peligros de incendio y para proporcionar una ventilación adecuada, mantenga el motor por lo menos a 1 metro de los edificios y de otro equipo durante su uso. No coloque objetos inflamables cerca del motor.
3. Mantenga a los niños y las mascotas alejados de la zona de trabajo, pues existe la posibilidad de quemaduras causadas por los componentes calientes del motor o lesiones causadas por cualquier equipo en el que se utilice el motor.
4. Sepa cómo apagar el motor rápidamente y comprenda el funcionamiento de todos los controles. Nunca permita a nadie operar el motor sin las instrucciones apropiadas.
5. La gasolina es extremadamente inflamable y es explosiva bajo ciertas condiciones.
6. Llene el tanque de combustible en un lugar bien ventilado y con el motor apagado. No fume ni permita que haya llamas ni chispas en la zona de llenado ni en donde se almacena el combustible.
7. No llene en exceso el tanque de combustible. Después de ponerle combustible, asegúrese de que la tapa del tanque esté cerrada completamente.
8. Tenga cuidado de no derramar el combustible. Los gases del combustible o el combustible derramado pueden encenderse. Si se derrama combustible, asegúrese de que la zona esté seca antes de encender el motor.
9. Nunca utilice el motor en un lugar encerrado o confinado. El escape contiene gas de monóxido de carbono venenoso; la exposición a este gas puede causar pérdida del conocimiento y puede conducir a la muerte.
10. El escape se calienta mucho durante su uso y permanece caliente durante un rato después de apagar el motor. Asegúrese de no tocar el escape cuando esté caliente. Para evitar quemaduras graves o peligros de incendio, deje que el motor se enfríe antes de transportarlo o guardarlo bajo techo.
11. Nunca envíe ni transporte la unidad con gasolina en el tanque.

ADVERTENCIA

No utilice este equipo para rociar agua o ácido.

PRECAUCION

No cargue el equipo por el asa del carrito durante la carga y descarga.

Parts Lists and Service Instructions

Main Assembly — Gas Model

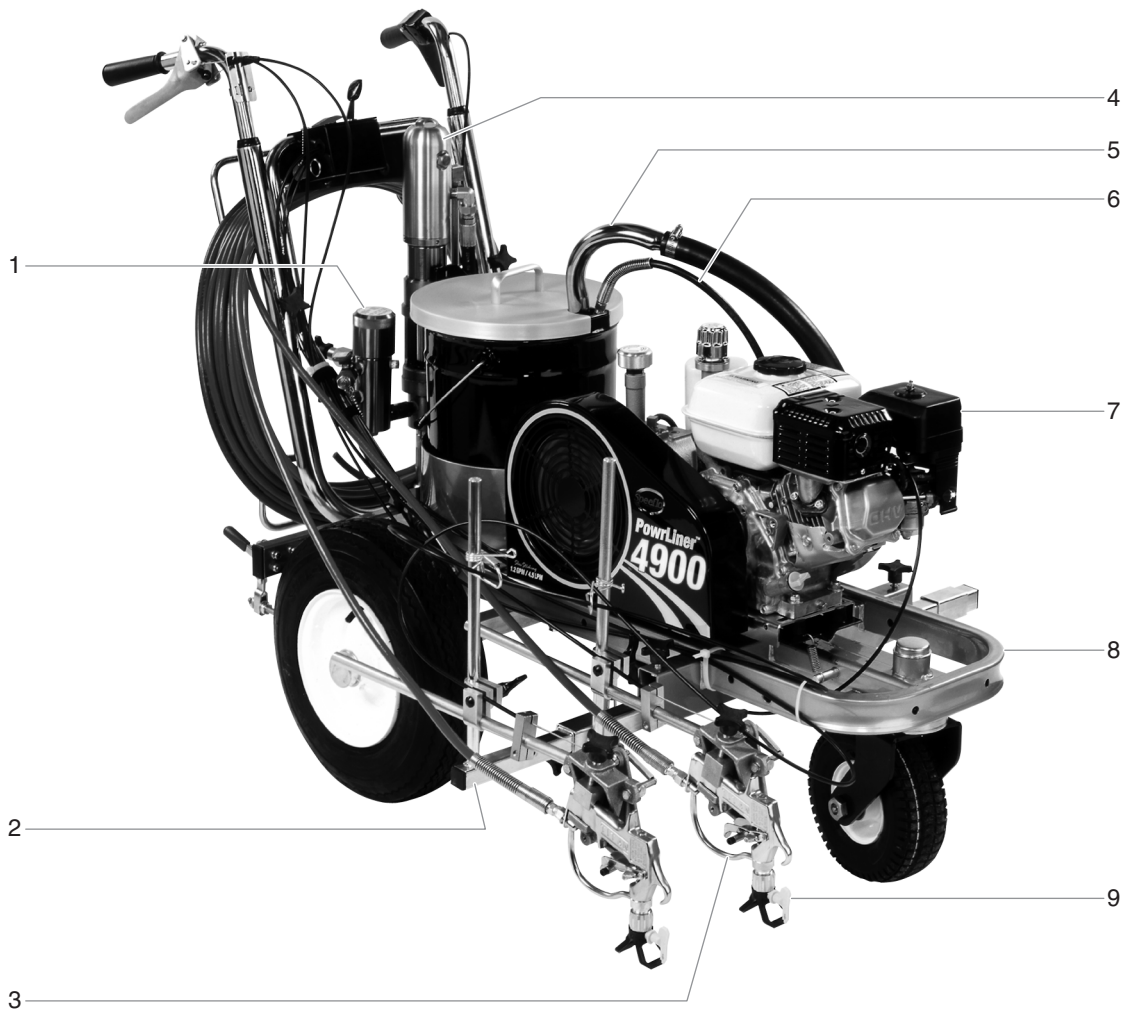

<u>Item</u>	<u>Part #</u>	<u>Description</u>	<u>One Gun</u> <u>759-490</u>	<u>Two Guns</u> <u>759-492</u>
1	930-515	Filter assembly, outlet manifold.....	1	1
2	759-038	Second gun kit.....	1	1
3	550-100	Airless Gun.....	1	2
4	235-107	Motor/pump assembly.....	1	1
5	103-841	Siphon hose assembly.....	1	1
6	840-212	Bleed line assembly w/ valve.....	1	1
7	506-145	Convertokit, 4 HP, Honda, Gasoline.....	1	1
8	779-001	Cart assembly.....	1	1
9	665-xxxx	SC-6 stripping tips (optional, see tip chart near the end of this section)		

Hydraulic System Assembly (P/N 779-027)

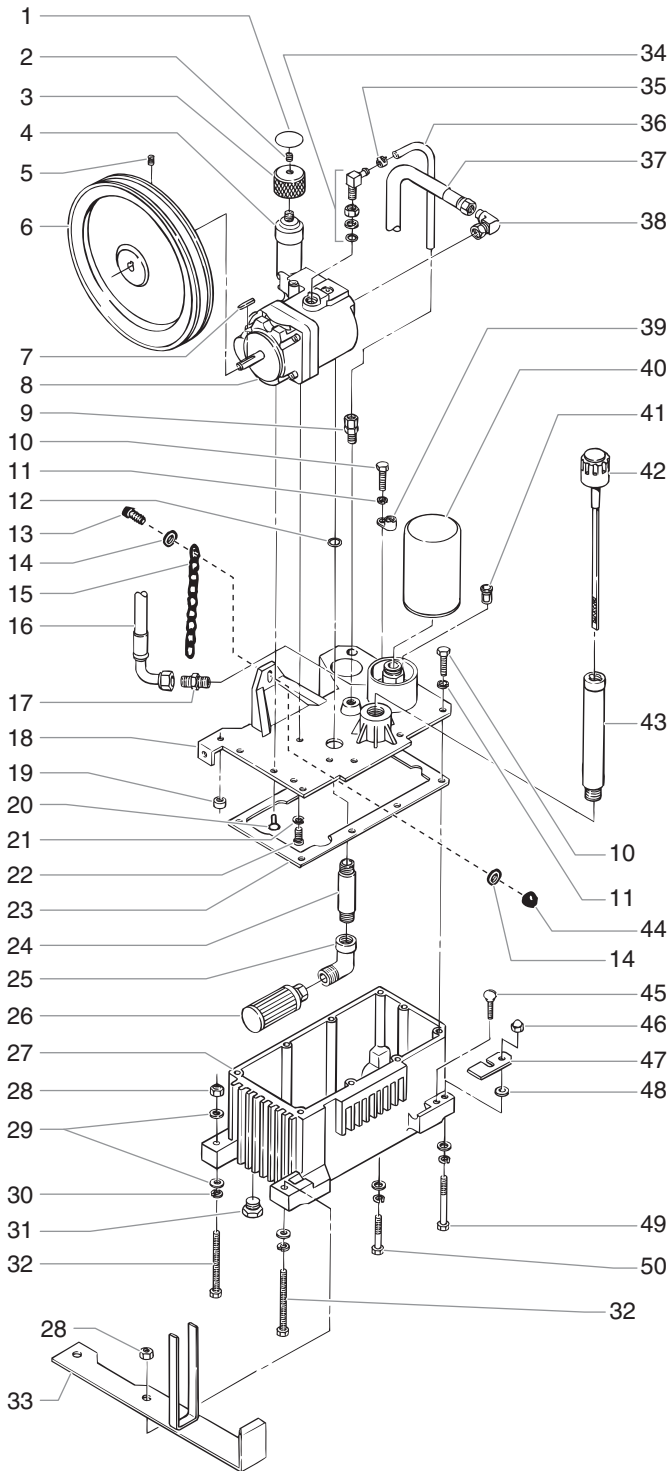

Item	Part #	Description	Quantity
1	313-755	Knob decal	1
2	862-414	Set screw	1
3	448-243	Pressure control knob	1
4	449-286	Pressure compensator	1
5	860-520	Set screw	1
6	448-250	Pulley/fan assembly	1
7	448-494	Key, pump (.156 x .156 x 1 ^{3/16})	1
8	449-751	Hydraulic pump (includes item 4)	1
9	431-042	Tube connector	1
10	858-636	Screw, HH	8
11	858-002	Lock washer	10
12	325-031	O-ring	1
13	860-528	Screw	1
14	860-002	Washer	2
15	424-283	Chain	1
16	424-236	Return hose assembly	1
17	451-029	Fitting	1
18	449-616	Tank cover	1
19	858-609	Clinch nut	1
20	858-621	Socket screw	2
21	859-001	Washer	2
22	858-624	Screw	2
23	449-605	Tank gasket	1
24	112-208	Nipple	1
25	472-500	Elbow, street	1
26	448-208	Inlet screen	1
27	449-623	Hydraulic tank	1
28	862-410	Flex lock nut	2
29	862-001	Flat washer	6
30	862-002	Lock washer	4
31	449-212	Plug	1
32	862-499	Screw, 4"	2
33	449-985	Shield	1
34	192-228	Elbow	1
35	449-126	Hose clamp	1
36	420-250	Tubing, Teflon	1
37	424-284	Pressure hose assembly	1
38	192-051	Elbow	1
39	101-205	Ground lug	1
40	451-220	Hydraulic filter	1
41	449-609	Hydraulic by-pass	1
42	449-626	Hydraulic fluid cap/dipstick	1
43	449-614	Tube assembly	1
44	860-502	Nut	1
45	862-438	Thumb screw	1
46	862-402	Acorn nut	1
47	449-107	Mounting plate retainer	1
48	449-135	Spacer	1
49	862-403	Screw, 3.5"	1
50	862-493	Screw, 3"	1
51	451-121	Elbow (not shown)	1
52	941-555	Ball valve (not shown)	1

Torque and Sealant Guide

Item	Description
5	Use blue Loctite on threads
9	Use hydraulic sealant
17	Use hydraulic sealant
20	Use blue Loctite on threads
20	Torque to 8 FT/LBS (11 N/m)
22	Torque to 8 FT/LBS (11 N/m)
24	Use hydraulic sealant
25	Use hydraulic sealant
26	Use hydraulic sealant
32	Torque to 15 FT/LBS (20,5 N/m)
40	Torque to 20 FT/LBS (28 N/m)
49	Torque to 15 FT/LBS (20,5 N/m)
50	Torque to 15 FT/LBS (20,5 N/m)

Gas Convertokit (P/N 506-145)

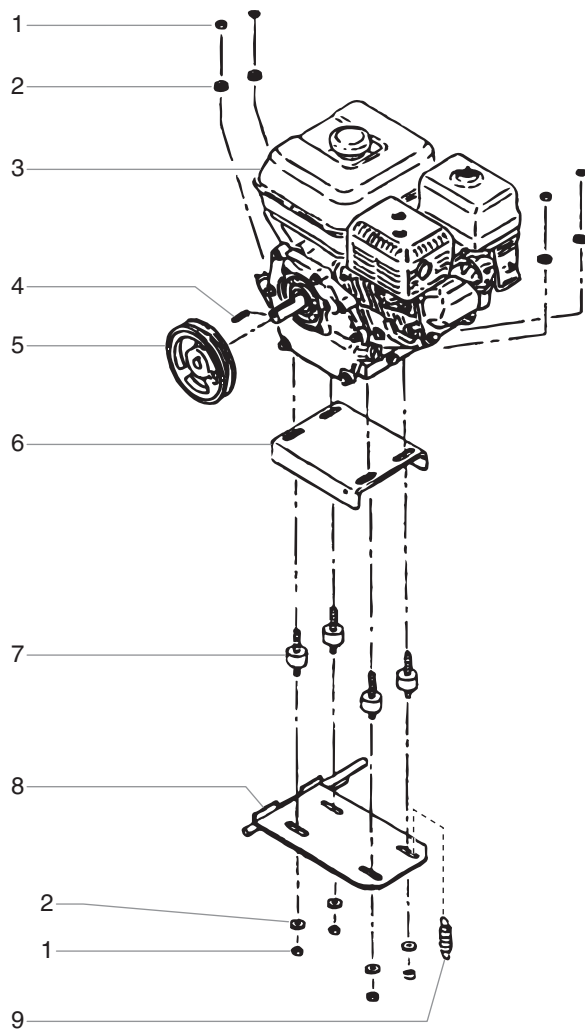

Item	Part #	Description	Quantity
1	860-502	Nut, stop.....	8
2	860-004	Washer, flat	8
3	750-200	Engine, gas 4.0 HP, Honda.....	1
4	980-307	Key	1
5	448-221	Pulley.....	1
6	449-144	Bracket	1
7	449-165	Vibration pad	4
8	449-219	Mounting plate.....	1
9	424-255	Spring	1
10	431-134	Belt. "V"	

(not shown, not part of assembly)

DC — Electric Convertokits

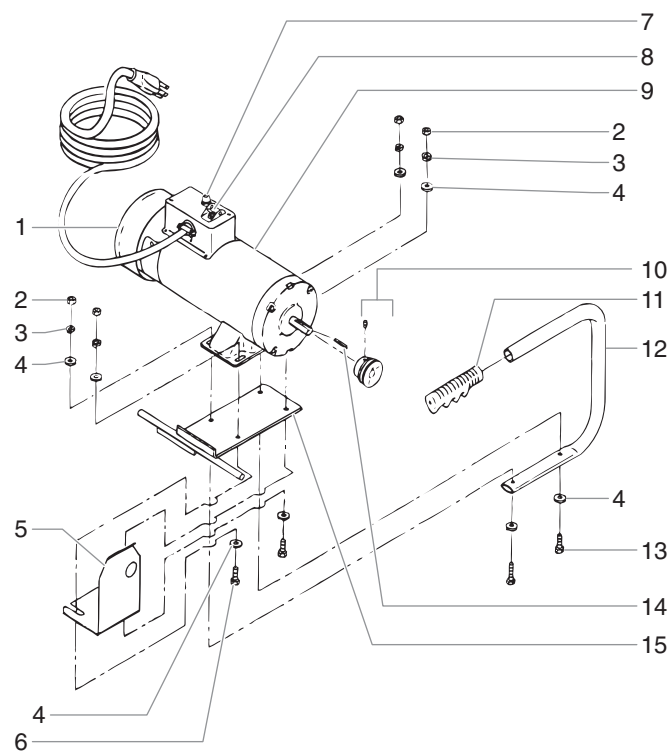

Item	Part #	Description	506-217 Qty.	506-214 Qty.
1	506-259	Cover.....	1	1
2	860-501	Nut, Stop	4	4
3	860-002	Washer, Lock	4	4
4	860-004	Washer, Flat	8	8
5	449-192	Motor shaft shield.....	1	1
6	860-535	Screw	2	2
7	978-040	Circuit breaker reset.....	1	1
8	506-260	ON/OFF switch.....	1	1
9	978-350	Motor, DC-Electric, 2 HP 50/60 Hz, 115 V	1	
	978-351	Motor,DC-Electric, 2 HP 50/60 Hz, 220 V		1
10	977-227	Pulley	1	1
11	590-068	Grip, Handle	1	1
12	335-017	Handle	1	1
13	860-552	Screw	2	2
14	980-307	Key	1	1
15	448-337	Mounting Plate	1	1
16	449-285	Belt, "V"		

(not shown, not part of assembly)

Siphon Hose Assembly (P/N 103-841)

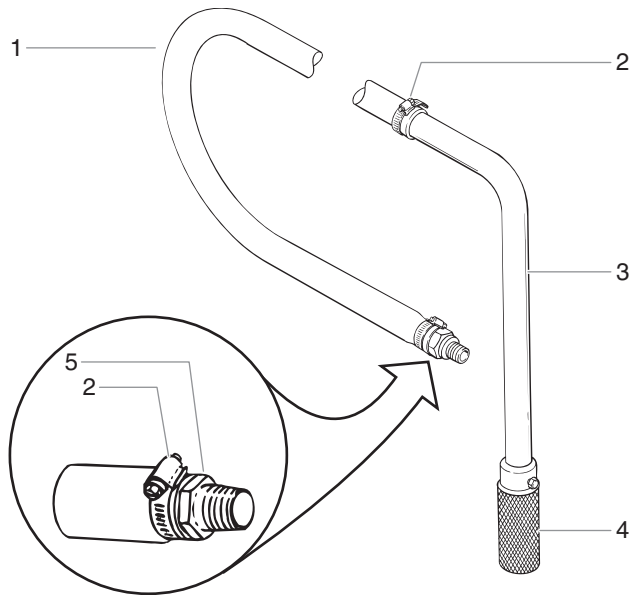

Item	Part #	Description	Quantity
1	779-191	Hose, 52"	1
2	103-679	Hose clamp	2
3	103-575	Tube	1
4	103-627	Intake screen.....	1
5	194-761	Adapter.....	1

Bleed Hose Assembly with Valve (P/N 840-211)

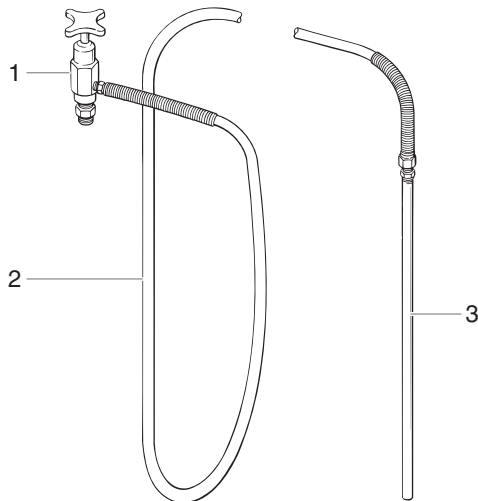

Item	Part #	Description	Quantity
1	944-028	Bleed valve.....	1
2	539-078	Hose assembly.....	1
3	103-117	Tube	1
4	103-111	Bleed line assembly (includes items 2 and 3).....	1

Bleed Valve Assembly (P/N 944-028)

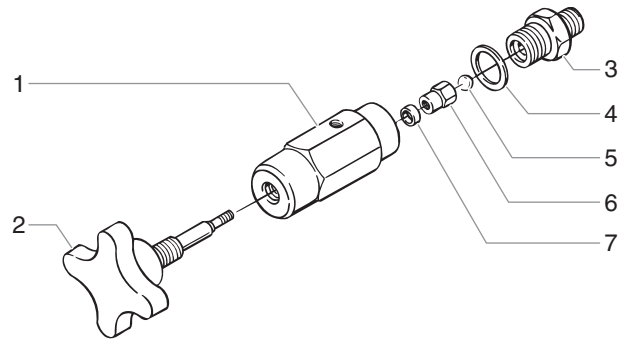

Item	Part #	Description	Quantity
1	944-020	Valve body.....	1
2	944-024	Knob assembly.....	1
3	944-904	Valve seat.....	1
4	945-003	Copper gasket.....	1
5	761-715	Ball, T.C.	1
6	944-026	Valve stem stop.....	1
7	944-004	O-ring, Teflon.....	1

Service Instructions

This bleed valve has a tungsten carbide valve seat and should not require frequent replacement. The tungsten carbide ball, in normal service, will last a long time because it rotates and wears evenly. If there is leakage, replace the ball.

CAUTION

Open the adjustment knob, to full counterclockwise position before unthreading valve seat, from valve body. If the valve stem is rotated inwardly with the ball removed, the Teflon o-ring may require replacement. If there has been leakage from the valve stem, the Teflon o-ring should be replaced

NOTE: The valve stem stop must be unthreaded from the valve stem with a socket screwdriver, then the valve stem can be threaded out of the valve body.

CAUTION

All non-moving threads must be assembled with Speedlo Loctite Sealant (P/N 426-051).

Wheel Assembly

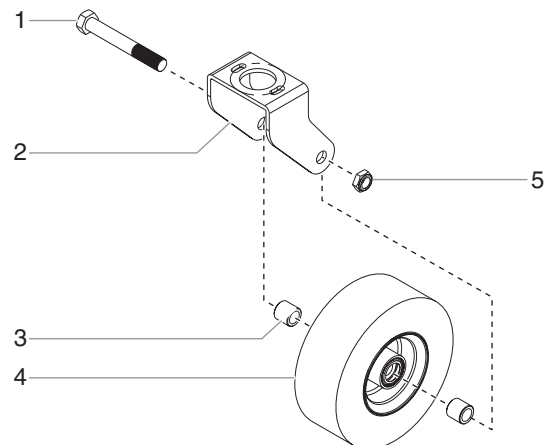

Item	Part #	Description	Quantity
1	779-018	Axle.....	1
2	779-011	Frame	1
3	779-017	Spacer	2
4	779-016	Wheel.....	1
5	779-019	Lock nut.....	1

Cart Assembly (P/N 779-001)

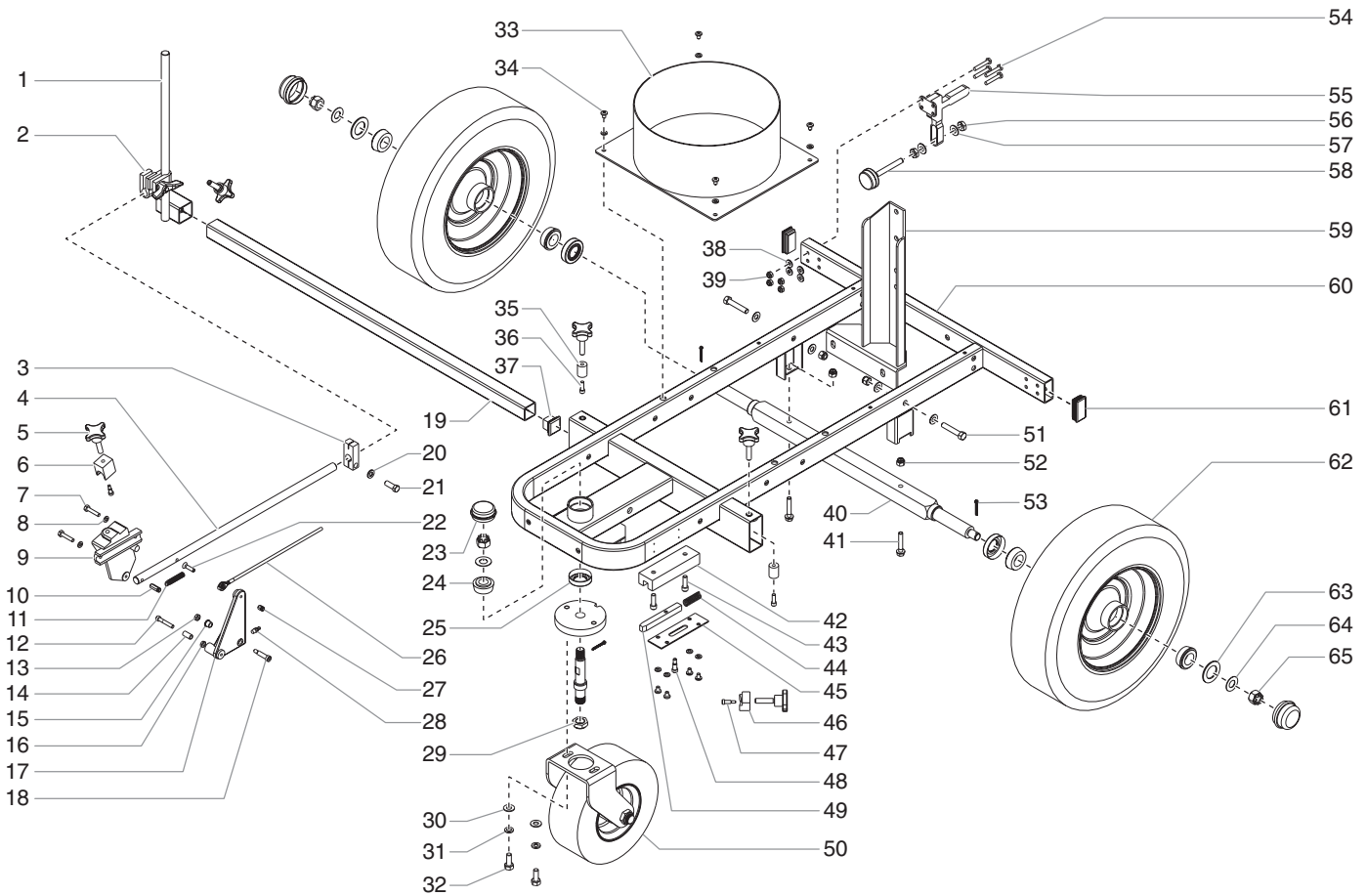

Item	Part #	Description	Quantity	Item	Part #	Description	Quantity
1	757-089	Slide tube weldment.....	1	34	700-784	Screw	8
2	779-083	Clamp assembly.....	1	35	757-022	Clamp rod.....	2
3	424-226	Cable mounting clamp	1	36	759-110	Screw	2
4	424-224	Support arm.....	1	37	757-055	Plastic end cap.....	1
5	756-034	Clamping knob.....	5	38	770-601	Flat washer.....	4
6	779-106	Clamp block.....	1	39	770-144	Lock nut, 1/4"	7
7	858-644	Screw	2	40	779-035	Axle	1
8	858-002	Lock washer, 1/4".....	10	41	761-178	Hex screw.....	2
9	424-201	Gun holder.....	1	42	779-118	Guide block	1
10	759-057	Spring holder (long).....	1	43	730-148	Socket screw.....	2
11	759-058	Return spring.....	1	44	756-087	Lock spring.....	1
12	858-653	Shoulder screw.....	1	45	759-014	Block cover.....	1
13	858-601	Jam nut.....	1	46	779-046	Block.....	1
14	424-249	Sleeve bearing	1	47	756-037	Shoulder screw.....	2
15	424-248	Flange bearing	2	48	759-016	Shoulder screw.....	1
16	858-603	Jam nut.....	1	49	779-138	Caster lock pin	1
17	424-202	Lever	1	50	-----	Wheel assembly (see separate listing)	1
18	860-936	Shoulder screw.....	1	51	862-468	Screw	2
19	757-014	Gun support bar	1	52	763-549	Lock nut, 5/16"	2
20	862-002	Lock washer	1	53	756-079	Cotter pin.....	3
21	862-436	Screw	1	54	858-652	Screw	4
22	703-079	Screw	1	55	424-271	Brake clamp	1
23	779-086	Dust cap	1	56	862-401	Nut.....	2
24	779-068	Taper bearing	2	57	860-004	Flat washer.....	2
25	779-085	Taper bearing seal.....	1	58	424-269	Brake pad	1
26	779-152	Gun cable	1	59	779-080	Pump support.....	1
27	759-056	Spring holder (short)	1	60	779-025	Frame	1
28	424-229	Grease fitting	1	61	779-121	Plastic plug	2
29	779-019	Lock nut, 3/4"	1	62	757-050	Rear wheel.....	2
30	862-001	Flat washer.....	2	63	176-919	Washer	2
31	862-002	Lock washer	2	64	756-080	Spring washer	3
32	862-436	Hex screw.....	2	65	756-078	Castle nut	3
33	779-136	Bucket holder	1				

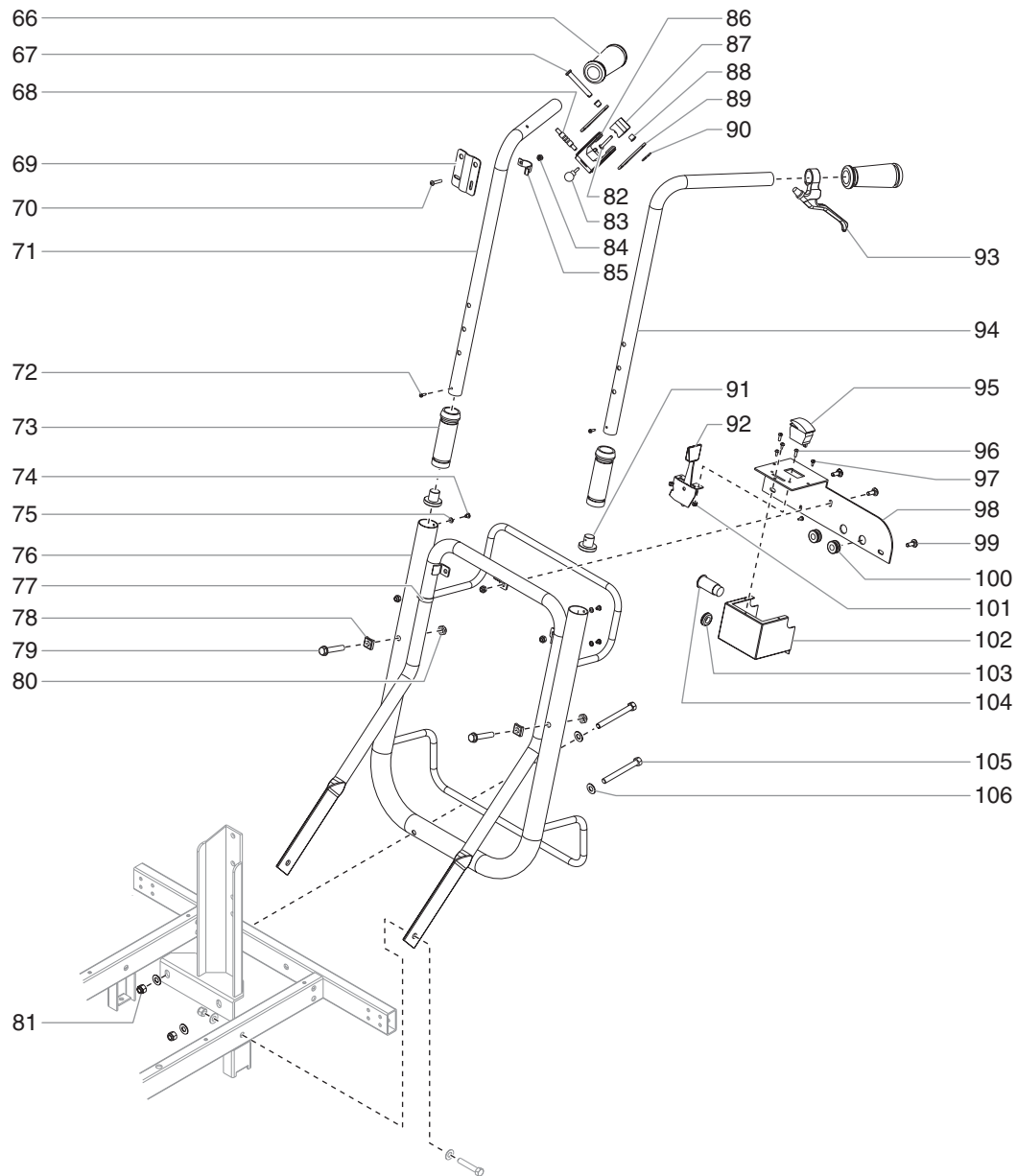

Item	Part #	Description	Quantity
66	424-245	Grip.....	2
67	759-015	Clevis pin.....	1
68	424-227	Selector spool.....	1
69	759-031	Cable guide plate.....	1
70	757-092	Screw.....	1
71	779-054	Handle bar, right.....	1
72	704-137	Screw.....	2
73	590-504	Handle sleeve.....	2
74	856-921	Screw.....	4
75	856-002	Lock washer.....	4
76	779-055	Handle assembly.....	1
77	424-247	Cable clip.....	1
78	779-104	Screw block.....	2
79	862-468	Screw.....	2
80	862-411	Nut.....	2
81	862-410	Lock nut, 3/8".....	4
82	856-744	Screw.....	2
83	759-033	Clamp knob.....	1
84	220-001	Lock nut.....	1
85	759-035	Strap.....	1
86	424-203	Trigger.....	1
87	424-219	Mounting block.....	1

Item	Part #	Description	Quantity
88	424-218	Flange bearing.....	2
89	424-217	Lever plate.....	2
90	759-034	Cotter pin.....	1
91	779-059	Handle guide.....	2
92	779-089	Throttle control.....	1
93	779-251	Trigger lever.....	1
94	779-056	Handle bar, left.....	1
95	779-090	Kill switch.....	1
96	700-139	Screw.....	2
97	779-193	Screw.....	4
98	779-057	Control plate.....	1
99	770-712	Carriage screw.....	3
100	800-036	Grommet.....	2
101	855-914	Lock nut.....	2
102	779-119	Control panel housing.....	1
103	773-932	Grommet.....	1
104	779-177	12V plug adapter.....	1
105	862-498	Screw.....	2
106	862-001	Flat washer.....	8
107	779-268	Caster cable (not shown).....	1
108	779-152	Gun cable (not shown).....	1

Hydraulic Motor

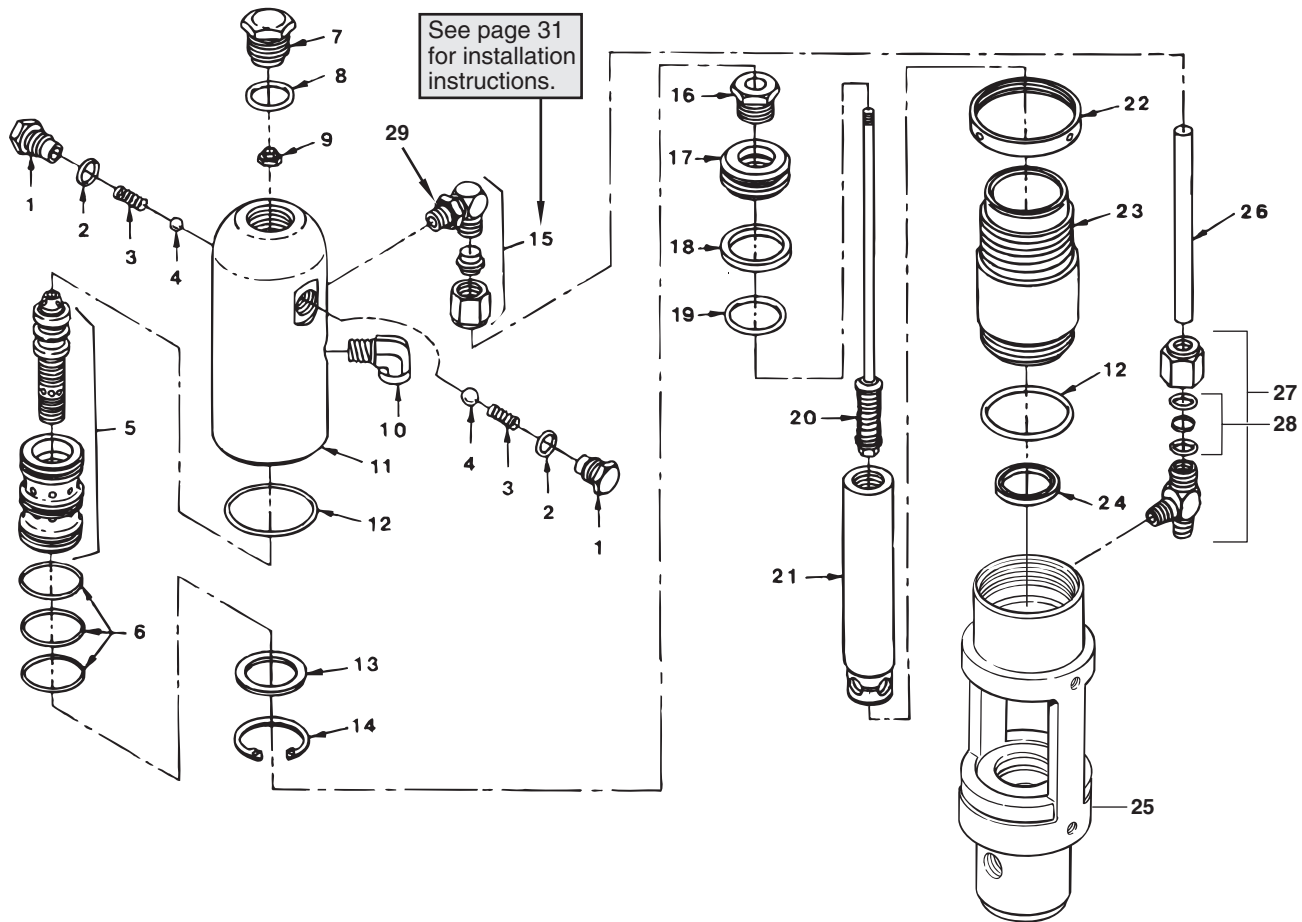

Item	Part #	Description	Quantity
1	235-018	Trip retainer	2
2	141-007	O-ring	2
3	325-005	Trip spring,	2
4	569-016	Ball, SS.....	2
5	441-908	Spool / sleeve set.....	1
6	441-152	O-ring	3
7	235-030	Cylinder head plug	1
8	441-217	O-ring	1
9	858-811	Flex lock nut.....	1
10	451-121	Male elbow, 90°.....	1
11	235-112	Cylinder head	1
12	431-032	O-ring	2
13	431-053	Sleeve retainer	1
14	431-054	Retainer ring.....	1
15	192-000	Elbow.....	1
16	235-022	Piston retainer screw.....	1
17	235-014	Piston	1
18	235-027	Piston seal.....	1
19	235-026	O-ring	1
20	235-021	Valve rod assembly	1
21	235-948	Piston rod	1
22	235-001	Lock ring.....	1
23	235-007	Cylinder	1
24	235-028	Rod seal	1
25	235-923	Motor/pump block.....	1
26	235-029	Motor tube	1
27	197-031	Tee.....	1
28	431-019	O-ring kit.....	1
29	700-499	O-ring	1

Motor Service Kit — Minor (P/N 235-050)

Item	Part #	Description	Quantity
2	141-007	O-ring	2
3	325-005	Trip spring	2
4	569-016	Ball, SS.....	2
6	441-152	O-ring	3
8	441-217	O-ring	1
9	858-811	Flex lock nut.....	1
12	431-032	O-ring	2
18	235-027	Piston seal.....	1
19	235-026	O-ring	1
24	235-028	Rod seal	1

Servicing the Hydraulic Motor

Perform this procedure using the necessary parts from Motor Service Kit — Minor (P/N 235-050). If the hydraulic motor is operable, start the machine and jog the piston rod (21) into its top position.

NOTE: Servicing of the hydraulic motor should be carried out in a clean, dust free area only. Any dust or metallic particles left in the motor or entering it on reassembly may damage the critical parts and affect its service life and warranty. All parts should be inspected for absolute cleanliness.

Disassembling the Hydraulic Motor

1. Disconnect the pressure hose from the elbow (36 and 37 in Hydraulic System parts list) on the back of the hydraulic pump.
2. Remove the two mounting screws and two lock washers that attach the motor/pump assembly to the pump support on the cart.

3. Place the motor/pump assembly in a vise, holding it securely by the motor/pump block (25).
4. Remove cylinder head plug (7).
5. Loosen lock ring (22) with a spanner wrench and unthread tube retaining nut on tee (27). Loosen tube retaining nut on elbow (15). Slide the nut down. Push motor tube (26) into tee (27) far enough to clear elbow (15). Slowly unthread cylinder head (11) and lift it just high enough above the cylinder (23) to reach the valve rod assembly (20) with vise grip pliers.
6. The piston rod (21) should be near the top of its stroke for disassembly. It may be necessary to use a wood or nylon driver to push the piston rod up to its top position.
7. Grip the valve rod securely with vise grip pliers and then remove the FlexLoc nut (9) from the top of the valve rod assembly (20). Be careful that spool (5) does not fall. The cylinder head (11) can now be lifted off. Unthread the cylinder (23) from the motor/pump block (25). Note: An extra lock ring (22) can be used to jam the two lock rings together on the cylinder and a pipe wrench can be used to unthread the cylinder (23) from the motor/pump block (25).

8. To remove the connecting pin, slide the retaining ring down with a small screwdriver, and then push the connecting pin out.
9. Remove the piston rod assembly from the motor/pump block (25).

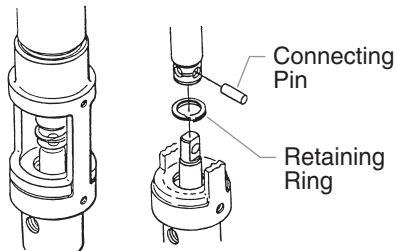

10. Remove rod seal (24), being extremely careful not to scratch the seal groove in the motor/pump block (25).
11. Place the piston retainer screw (16) on the piston rod assembly in a vise. Slide a long bar through the hole at the base of the piston rod for leverage, and unthread the piston rod from the piston retainer screw.
12. Remove piston (17) and lift out valve rod assembly (20).
13. Remove piston seal (18) and o-ring (19).
14. Remove trip retainers (1), trip springs (3), and balls (4) from cylinder head (11). Remove o-rings (2) from trip retainers (1).
15. Remove retaining ring (14) and sleeve retainer (13). Gently tap spool/sleeve set (5) out of cylinder head (11) using a wood or nylon rod.
16. Inspect piston rod (21) and cylinder (23) for wear, scratches, and dents. Replace if damaged.
17. Inspect spool valve (5) for wear. Replace if necessary. spool valve should move smoothly and freely with no force by holding in a vertical position. If it does not, it can cause the motor to stall.

Reassembling the Hydraulic Motor

1. Separate spool/sleeve set (5). Place o-rings (6) onto sleeve. Lubricate o-rings with hydraulic oil. Gently push the sleeve into cylinder head (11) with the flatter side of the sleeve facing out. Use a nylon rod to tap sleeve down until it reaches its full depth. Do not use any other type of tool that might damage or leave particles or residue on the sleeve. Install the spool through the top of the cylinder head, down into the sleeve.



Do not use Piston Lube pump packing lubricant. It is a solvent and will severely damage seals and O-Rings of the hydraulic motor.

2. Install o-rings (2) on trip retainers (1). Install trip retainer balls (4) followed by springs (3) which, when installed, will hold spool/sleeve set (5) in proper place for assembly.

3. Install sleeve retainer (13) followed by snap ring (14) into cylinder head (11), which will hold valve sleeve in place. Install o-ring (12) in the o-ring groove of the cylinder head.
4. Replace lower seal (24) in motor/pump block (25). Be sure the open portion of the seal is facing upward (V). This seal requires no special tool.
5. Place piston rod (21) in vise. Inspect valve rod assembly (20) for any damage. Make sure the lock nut at the bottom of the valve rod assembly (20) is secure. DO NOT remove. Then, place into piston rod (21) as illustrated. Install o-ring (19), lubricating it well and replacing piston (17) onto piston rod (21). Put one drop of blue Loctite on the piston retainer screw (16). Tighten piston retainer screw until piston is locked into place. Check valve rod assembly (20) for normal spring action at this time.
6. Install piston seal (18) with lips facing downward. Carefully install o-ring (19). Expand the ring and stretch it sufficiently for installation.
7. With motor/pump block (25) still in vise, install lower seal (24) by pushing it towards its groove with a properly sized blunt rod. Then complete installation with the fingers. No tool is necessary. Do not twist the seal.
8. Pre-lubricate the piston and valve rod assembly with Coolflo™ hydraulic fluid (P/N 430-361). Install piston rod (21) into motor/pump block (25) with a gently pushing and rotating motion to work the piston rod in through the seal (24).

NOTE: Inspect the bottom of piston rod (21) for nicks or sharp areas that could damage the piston seal during installation through the motor/pump block (25).

9. Replace the connecting rod pin and retainer ring.
10. Install o-ring (12) on cylinder wall. Lubricate ring and inner wall. With the piston rod held firmly, the cylinder should be gently driven over the piston seal with a rubber mallet. Tightly thread the cylinder into motor/pump block (25).
11. Raise piston rod (21) to top position and thread lock ring (22) all the way up on upper threads of cylinder (23).
12. Pull valve rod assembly (20) up as far as it will travel and grasp it with vise grip pliers. Then install cylinder head (11), already assembled, over valve rod until the top threads of the valve rod pass through the top of the spool/sleeve set (5). The valve rod threads must be clean and free of oil. Place one drop of blue Loctite on threads of flex lock nut (9) and thread nut onto valve rod to full tight position (do not over-tighten) while holding valve rod below with vise grip pliers.
13. Thread cylinder head (11) down onto the cylinder (23) and then back off just enough to reassemble hydraulic fittings and motor tube (26). Tighten lock ring with spanner wrench to hold cylinder head in position.
14. The tee assembly (27) and the elbow (15) use an o-ring (28) to seal on the outer diameter (O.D.) of the motor tube (26). The O.D. of the motor tube should be free of scratches or sharp edges. The lock nuts on these fittings first should be hand tightened, then wrench tightened another half turn.
15. Install o-ring (8) onto cylinder head plug (7). Tighten.

Hydraulic Motor Cut-Away

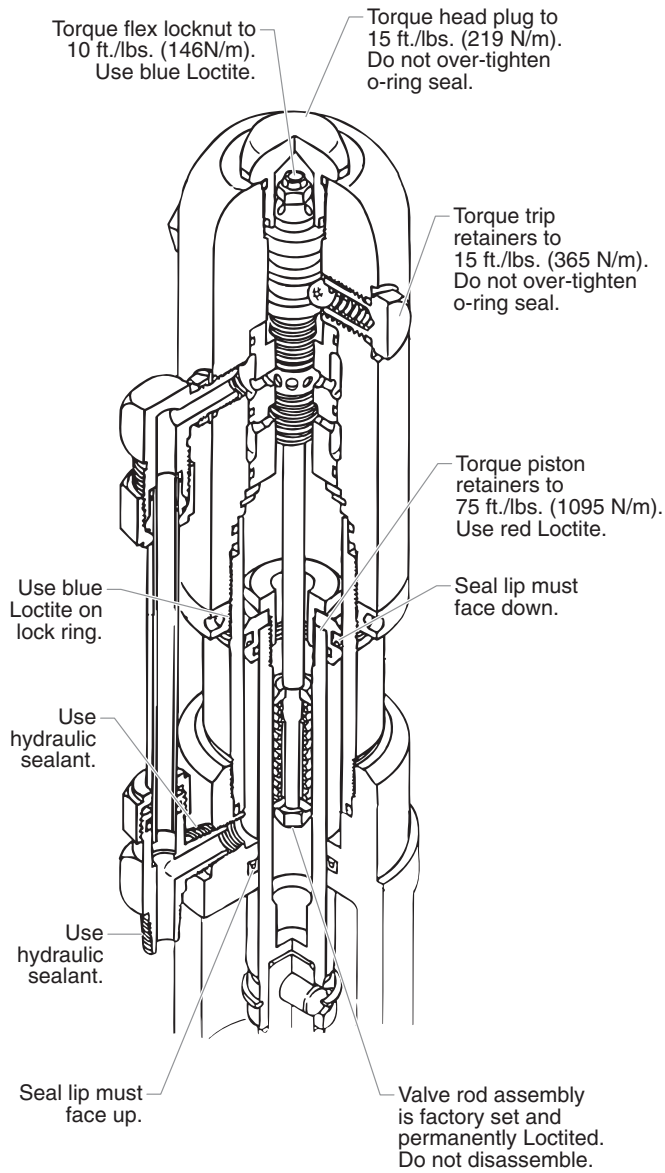

Fluid Section

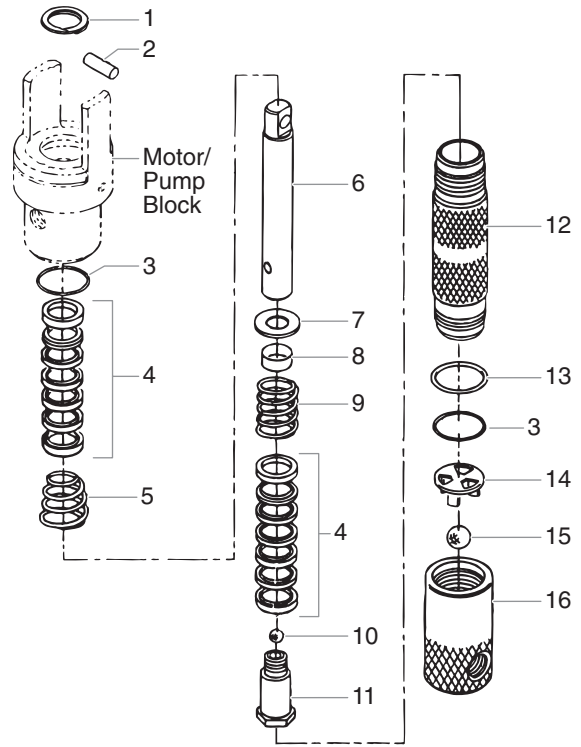

Item	Part #	Description	Quantity
1	143-019	Retainer ring.....	1
2	107-003	Connecting pin	1
3	106-015	O-ring, Teflon.....	2
4	106-002	Packing set, leather/UHMPWPE/steel	2
5	106-005	Upper packing spring, SS	1
6	107-029	Displacement rod, Severe Service 500.....	1
7	106-001	Spring retainer.....	1
8	106-116	Sleeve	1
9	106-016	Lower packing spring, SS	1
10	569-021	Ball, SS.....	1
11	106-011	Piston seat.....	1
12	107-936	Pump cylinder, Severe Service 500	1
13	106-014	O-ring	1
14	106-012	Ball cage, SS.....	1
15	138-340	Ball, SS.....	1
16	107-013	Foot valve assembly	1

Fluid Section Service Kit — Major (P/N 107-501)

Item	Part #	Description	Quantity
6	107-019	Displacement rod	1
12	107-936	Pump cylinder.....	1
	107-051	Pump Service Kit, Minor.....	1

Fluid Section Service Kit — Minor (P/N 107-051)

Item	Part #	Description	Quantity
1	143-019	Retainer ring.....	1
3	106-015	O-ring, Teflon.....	2
4	106-002	Packing set, leather/UHMWPE/steel.....	2
10	569-021	Ball, SS.....	1
13	106-014	O-ring	1
15	138-340	Ball, SS.....	1
	426-051	Loctite sealant	1

Servicing the Fluid Section

NOTE: USE OF NON-SPEEFLO SERVICE PARTS MAY VOID WARRANTY. ASK FOR ORIGINAL PARTS MADE BY SPEEFLO FOR BEST SERVICES. This pump should receive a routine servicing after approximately 1,000 hours of use. Earlier servicing is required if there is excessive leakage from the top packing or if pump strokes become faster on one stroke or the other. The use of Speeflo Piston Lube (P/N 700-925) is recommended as an upper packing lubricant. DO NOT SUBSTITUTE OIL, WATER, OR SOLVENT for an upper packing lubricant.

Disassembling the Fluid Section

1. Remove siphon tube assembly. Unthread the foot valve (16) and the pump cylinder (12) with a strap wrench.
2. Slide the retainer ring (1) up with a small screwdriver, then push the connecting pin (2) out.
3. Pull the displacement rod (6) through the lower cavity of the motor/pump block.
4. Remove the motor/pump block, Teflon o-ring (3), upper packing spring (5), and upper packing set (4).
5. Hold the displacement rod (6) in a vise by the flats at the top of the displacement rod and remove the piston seat (11) with a wrench while holding the displacement rod horizontal with wooden support, if necessary. Remove the ball (10), lower packing set (4), lower packing spring (9), sleeve (8), and spring retainer (7).
6. Remove the ball cage (14), Teflon o-ring (3), and ball (15).
7. Replace the connecting pin (2) and retainer ring (1).
8. Remove the o-ring (13) from the pump cylinder (12).

Reassembling the Fluid Section

NOTE: Use Teflon tape on all threaded pipe connections.

1. Place the ball (15) into the foot valve (16), followed by the ball cage (14).
2. Insert the Teflon o-ring (3) into the lower groove of foot valve (16).
3. Place the lower packing set (4) onto the piston seat (11) with the peak of the "V" packings pointing down toward the foot valve.

NOTE: The packings must be soaked in oil before installation.

4. Clean the threads on the piston seat (11) and coat the threads with blue Loctite. Make sure no Loctite is on the seat.
5. Place the ball (10) onto the piston seat (11).
6. Place the lower packing spring (9) onto the piston seat (11), followed by the sleeve (8) and the spring retainer (7).
7. Screw the displacement rod (6) and the piston seat (11) together. Tighten in a vise to 75 ft./lbs.
8. Insert the Teflon o-ring (3) into the upper groove of the motor/pump block.
9. Insert the upper packing set (4) into the motor/pump block with the peak of the "V" packings pointing up toward the motor.

NOTE: The packings must be soaked in oil before installation.

10. Place the upper packing spring (5) into the motor/pump block with the small tapered end facing up toward the motor/pump block.
11. Insert the displacement rod (6) up through the upper packings in the motor/pump block.

12. Align the holes in the displacement rod (6) and the hydraulic piston rod and insert the connecting pin (2).
13. Thread the short threads of the pump cylinder (12) into the motor/pump block and tighten with a strap wrench.
14. Place the o-ring (13) onto the top groove of the pump cylinder (12).
15. Thread the foot valve (16) onto the pump cylinder (12), tighten with a strap wrench, then back off to align the siphon hose.

NOTE: It is not necessary to over-tighten the foot valve. O-ring seals perform sealing function without excessive tightening. Full thread engagement is sufficient. The foot valve may be rotated backward up to 1/2 turn from full engagement for convenient hose position.

For siphon hose attachment, it is critically important that the threads of the siphon hose fit snugly into the foot valve with the hose assembly couplings Teflon taped and sealed to prevent air leakage.

Fluid Section Cut-Away

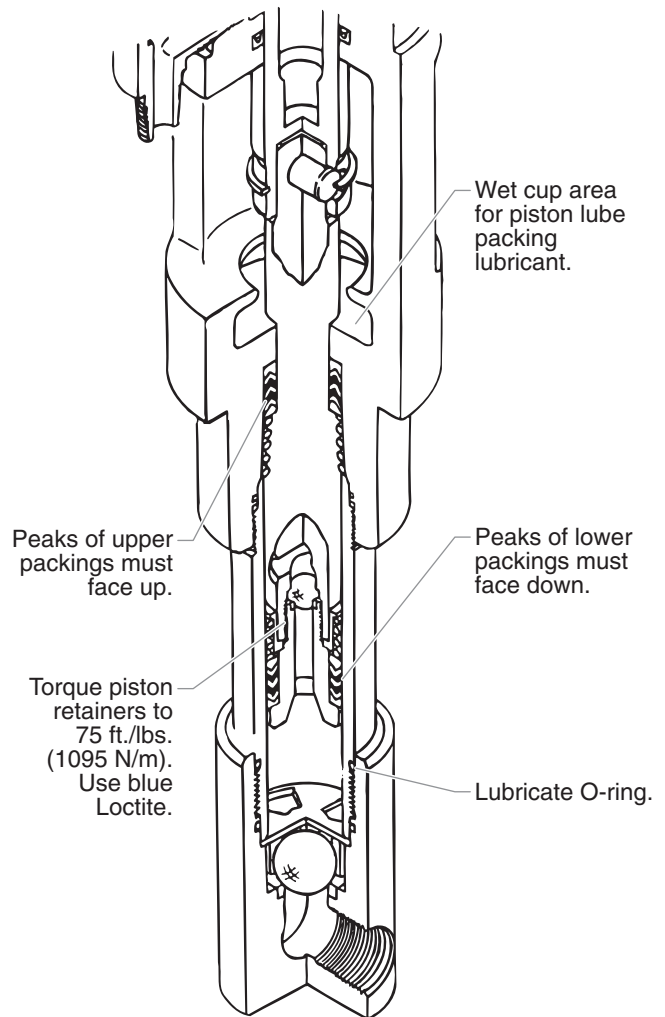

SAE O-Ring Fitting Installation

Steps 1 & 2:

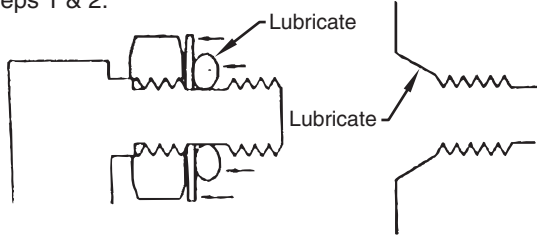

Step 3:

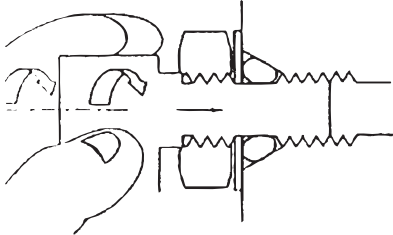

1. Pull washer and o-ring back as far as possible.
2. Lubricate o-ring and entrance port.
3. Screw fitting in until washer pushes o-ring into entrance and sits flat against port. (Do not tighten! - only do this step hand tight to compress o-ring into port!)

Step 4:

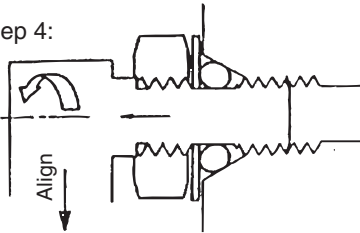

4. Back fitting out no more than one complete turn to align as required.

Step 5:

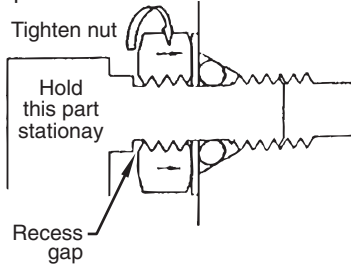

5. Torque nut wrench tight holding backup on fitting. This should expose a recess gap behind the nut which can act as an indicator that the fitting is assembled correctly. (This is a feature for a specific version of this fitting only - which screws into the cylinder head. Other fittings, as the ones which attach to the hydraulic pump, assemble the same but may not have the indicator.)

Cautions:

Avoid screwing fitting in too far.

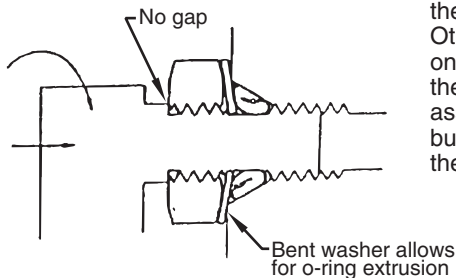

Avoid leaving fitting too far out.

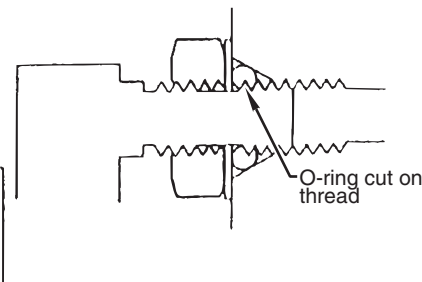

Accessories and Service Kits

These items may be purchased separately from your local Speedflo distributor.

Part #	Description
103-627	Rock Catcher
520-050	SGX-20 G, T, and 1/4" x 50' Hose Kit
520-051	SGX-20 G, T, and 3/8" x 50' Hose Kit
580-050	LX-80 G, T, and 1/4" x 50' Hose Kit
101-208	Grounding Clamp
101-212	Grounding Wire, 12 Gauge x 25'
314-480	Piston Lube
430-362	Coolflo™ Hydraulic Fluid, 1 Quart
430-361	Coolflo™ Hydraulic Fluid, 1 Gallon
107-051	Fluid Section Service Kit — Minor
920-050	Filter Service Kit
944-050	Bleed Valve Service Kit
611-275-1	6" Gun Extension
611-276-1	12" Gun Extension
611-277-1	18" Gun Extension
611-278-1	24" Gun Extension
930-005	Filter element, 5 mesh, w/ball
930-007	Filter element, 100 mesh, w/ball
759-145	Headlight Kit
759-120	Floating Gun Kit
759-130	Paint Hopper
759-038	Second Gun Kit (with gun)
759-076	Second Gun Kit (without gun)
759-140	Lazer Pointer
424-650	Self Propulsion Module
759-150	Side Striper
424-826	Bead Dispenser, 1st Gun Kit, 4-6" line width
424-816	Bead Dispenser, 2nd Gun Kit, 4-6" line width
424-836	Bead Dispenser, 2nd Gun Kit w/Hopper, 4-6" line width
424-840	Bead Dispenser, 1st Gun Kit w/Hopper, 12" line width
424-841	Bead Dispenser, 2nd Gun Kit w/Hopper, 12" line width

Second Gun Assembly (P/N 759-038 with gun P/N 759-076 without gun)

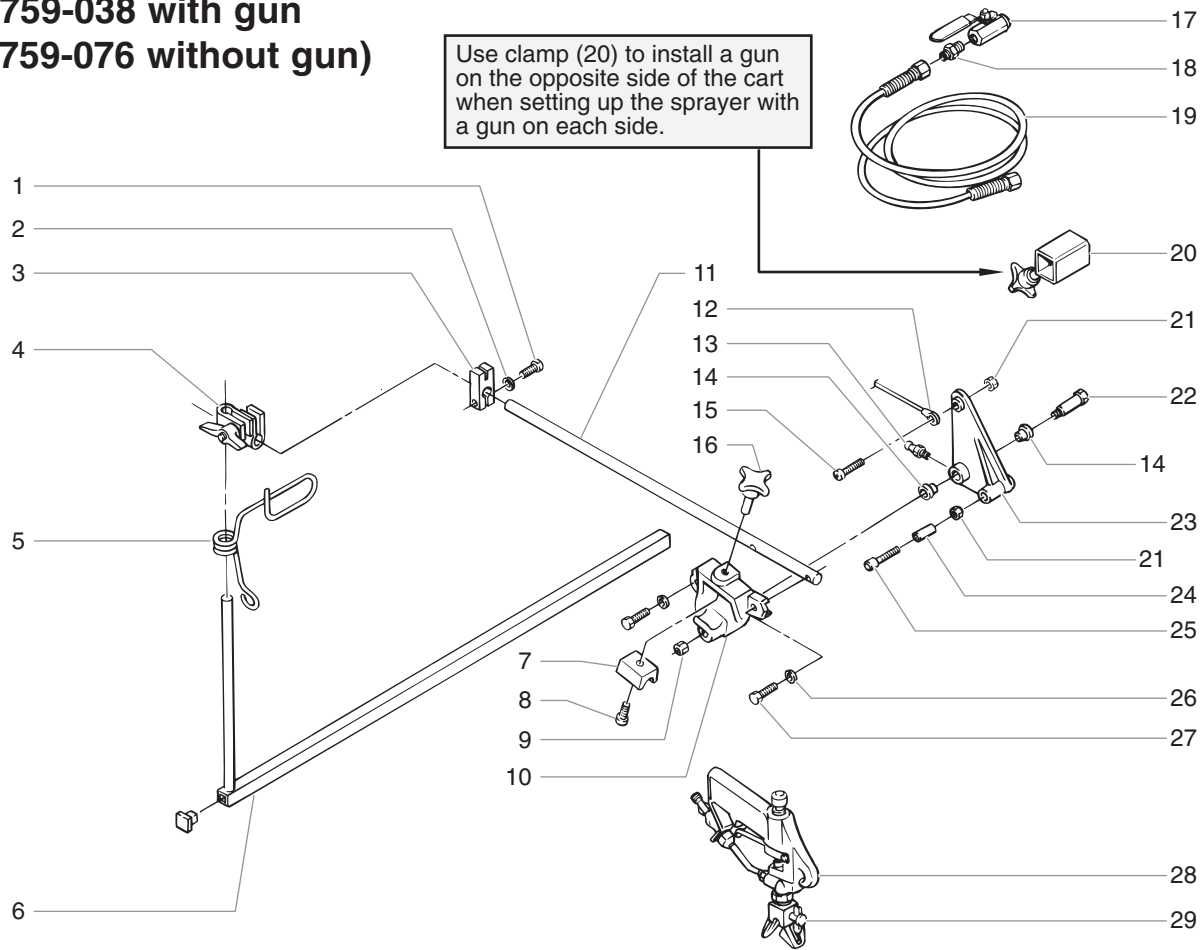

Item	Part #	Description	Quantity
1	862-436	Hex screw.....	1
2	862-002	Lock washer.....	1
3	424-226	Cable mounting clamp.....	1
4	779-083	Clamp assembly.....	1
5	424-288	Cable guide.....	1
6	756-124	Extension bar.....	1
7	779-106	Clamp.....	1
8	858-912	Screw, shoulder.....	1
9	858-601	Nut.....	1
10	424-201	Gun holder.....	1
11	424-224	Support arm.....	1
12	779-152	Gun control cable assembly.....	1
13	424-229	Grease fitting.....	1
14	424-248	Flanged bearing.....	2
15	858-637	Screw.....	1
16	756-034	Knob.....	2
17	940-553	Ball valve.....	1
18	227-006	Hex nipple.....	1
19	316-533	Hose assembly, 4'.....	1
20	779-132	Clamp.....	1
21	858-603	Nut.....	2
22	860-936	Screw, shoulder.....	1
23	424-202	Actuator lever.....	1
24	424-249	Sleeve bearing.....	1
25	858-653	Screw, socket head.....	1
26	858-002	Lock washer.....	2
27	858-636	Screw, hex head.....	2
28	550-100	Airless gun, S-5.....	1
29	661-517	Reversible tip, SC6.....	1
	665-1908	Striping tip, SC6.....	1

Second Gun Installation

NOTE: The gun support beam must be removed to install the second gun and hose. The sprayer must be shut down before installation.



Before installing the second gun, follow the "Pressure Relief Procedure" in the Operation section of this manual. Once you have completed this procedure, unplug the power supply cord. Failure to reduce pressure can result in serious injury.

1. Engage the first gun's trigger lock.
2. Remove the trigger cable from the block of the first gun.

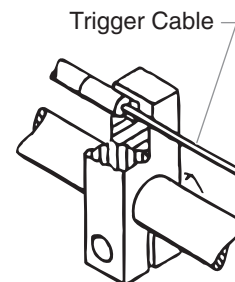

NOTE: The gun or guns can be installed on either side of the cart and can face either forward or backward. Refer to the “Spray Gun Positions” illustration near the back of this manual.

3. Remove the plastic plug from the gun support bar. Slide the extension bar through the clamp upright and the gun support bar to the desired position. Tighten the clamp knob to secure the clamp upright and the extension bar.

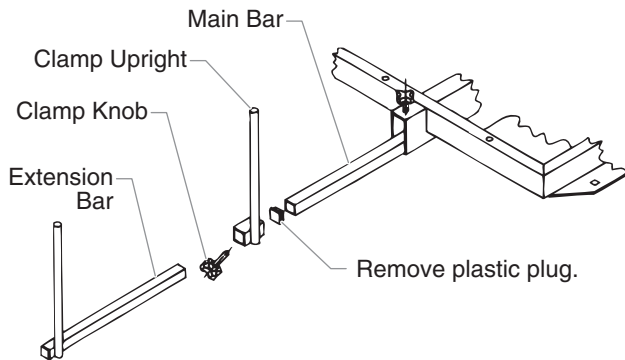

NOTE: The gun support bar has a clearance hole for the clamp knob to go through and tighten on the extension bar.

4. Mount the gun holders as shown in the Cart Assembly exploded view drawing in this section.
5. Locate the second gun outlet on the pump filter. Remove the plug and install the hex nipple and ball valve. Thread the second gun hose onto the hex nipple.

NOTE: Once the second gun is in position, the trigger cables can be installed on both guns. Make sure the trigger cable from the second gun is disconnected before performing the next step.

6. Insert the cable bushing into the guide plate. The first gun cable and the second gun cable should be parallel.
7. Insert the hooked end of the cable into the lever plate. Make sure it engages the plate.

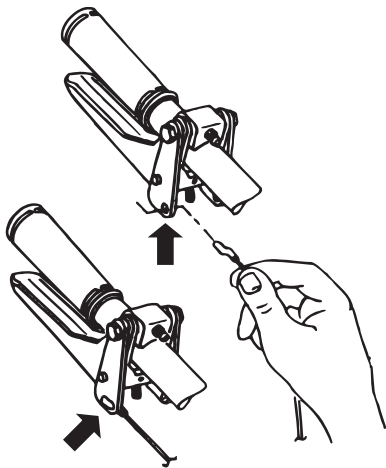

8. Reconnect the trigger cables to the guns. Connect both cables to the blocks.

Tension Adjustment

To increase tension, loosen the screw in the cable tension clamp block on the gun arm. Slide the block forward to increase the gap between the lever and the point where the trigger touches the gun arm.

To decrease tension, slide the block backwards. Make sure there is about 1/32" to 1/16" gap between the trigger lever and where the trigger touches the bar.

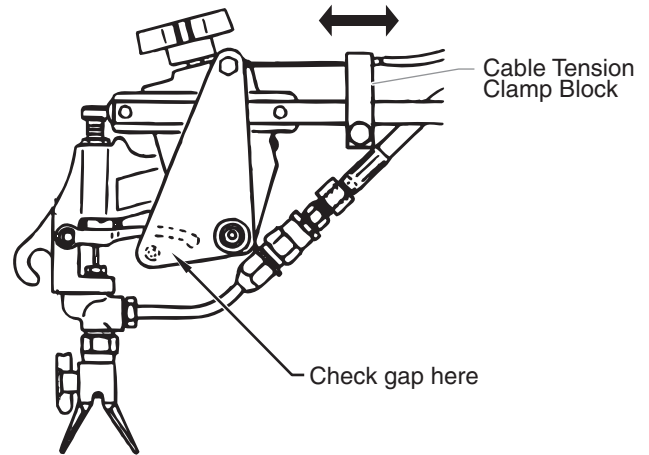

CAUTION

Always turn the trigger lock on the spray gun to the locked position before making any adjustments to the gun. Also, release the trigger cable from its block by lifting the cable up and out of the block. There will be a brief triggering of the gun while releasing the trigger cable.

SC-6 Striping Tip Chart

Tip Part #	Line Width	Orifice Size	Common Uses
665-1302	1"-4" (25-102 mm)	.013" (.33 mm)	Stencils & Athletic Courts — Light film (use 100 mesh filter)
665-1304	2"-3" (51-76 mm)	.013" (.33 mm)	Stencils & Athletic Courts — Light film (use 100 mesh filter)
665-1308	4"-8" (102-203 mm)	.013" (.33 mm)	Stencils & Athletic Courts — Light film (use 100 mesh filter)
665-1502	1"-4" (25-102 mm)	.015" (.38 mm)	Stencils & Athletic Courts — Alkyd only, light film
665-1504	2"-3" (51- 76 mm)	.015" (.38 mm)	Stencils & Athletic Courts — Light film
665-1508	4"-8" (102-203 mm)	.015" (.38 mm)	Stencils & Athletic Courts — Light film
665-1702	1"-4" (25-102 mm)	.015" (.33 mm)	Stencils & Athletic Courts — Alkyd only, heavy film
665-1704	2"-3" (51- 76 mm)	.017" (.43 mm)	Most traffic paints — Medium film
665-1708	4"-8" (102-203 mm)	.017" (.43 mm)	Most traffic paints — Light film
665-1904	2"-3" (51- 76 mm)	.019" (.48 mm)	Most traffic paints — Heavy film
665-1908	4"-8" (102-203 mm)	.019" (.48 mm)	Most traffic paints — Medium film
665-2108	4"-8" (102-203 mm)	.021" (.53 mm)	Most traffic paints — Heavy film
665-2112	6"-12" (152-305 mm)	.021" (.53 mm)	Most traffic paints — Light film
665-2308	4"-8" (102-203 mm)	.023" (.58 mm)	Most traffic paints — Heavy film
665-2312	6"-12" (152-305 mm)	.023" (.58 mm)	Most traffic paints — Medium film
665-2508	4"-8" (102-203 mm)	.025" (.64 mm)	Most traffic paints — Very Heavy film
665-2512	6"-12" (152-305 mm)	.025" (.64 mm)	Most traffic paints — Heavy film
665-2708	4"-8" (102-203 mm)	.027" (.69 mm)	Most traffic paints — High speed, light film
665-2712	6"-12" (152-305 mm)	.027" (.69 mm)	Most traffic paints — Heavy film
665-2908	4"-8" (102-203 mm)	.029" (.74 mm)	Most traffic paints — High speed, medium film
665-2912	6"-12" (152-305 mm)	.029" (.74 mm)	Most traffic paints — High speed, light film
665-3108	4"-8" (102-203 mm)	.031" (.79 mm)	Most traffic paints — High speed, heavy film
665-3112	6"-12" (152-305 mm)	.031" (.79 mm)	Most traffic paints — High speed, medium film
665-3508	4"-8" (102-203 mm)	.033" (.84 mm)	Most traffic paints — High speed, heavy film
665-3512	6"-12" (152-305 mm)	.035" (.89 mm)	Most traffic paints — High speed, heavy film
665-3908	4"-8" (102-203 mm)	.039" (.99 mm)	All traffic paints — High speed, heavy film
665-3912	6"-12" (152-305 mm)	.039" (.99 mm)	All traffic paints — High speed, heavy film
665-4308	4"-8" (102-203 mm)	.043" (1.09 mm)	All traffic paints — High speed, heavy film
665-4312	6"-12" (152-305 mm)	.043" (1.09 mm)	All traffic paints — High speed, heavy film

NOTE: Divide the last two digits of the SC-6 striping tip part number by 2 to determine the fan width of the tip.
Example: A tip with the part number 665-1308 has a .013" orifice and produces a 4" fan width.

Electrical Schematic

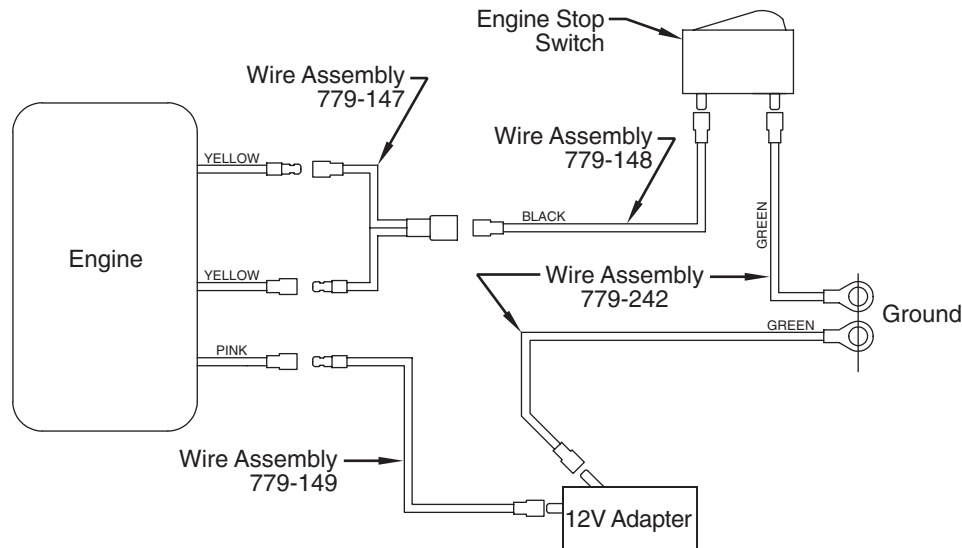

Spray Gun Positions

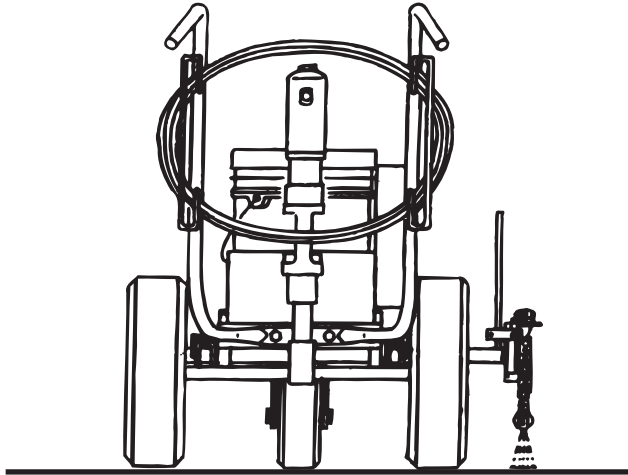

Single Line

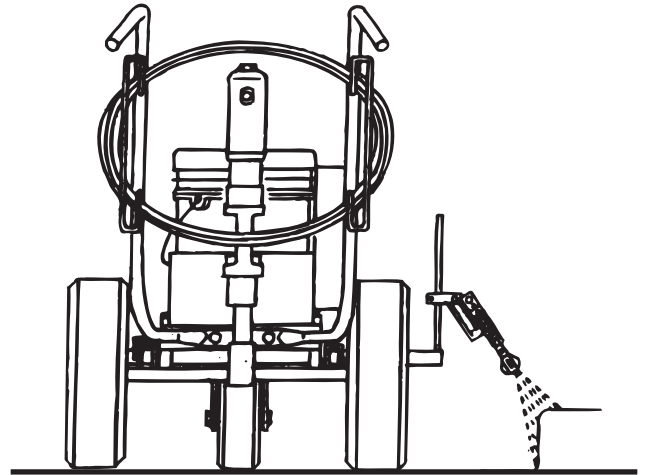

One Gun Curb

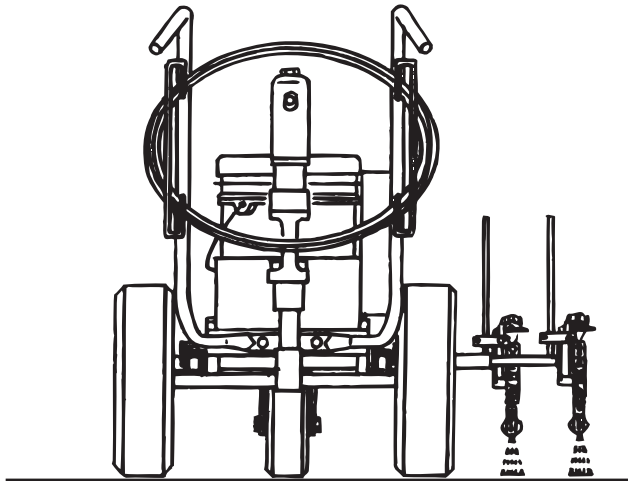

Two Lines

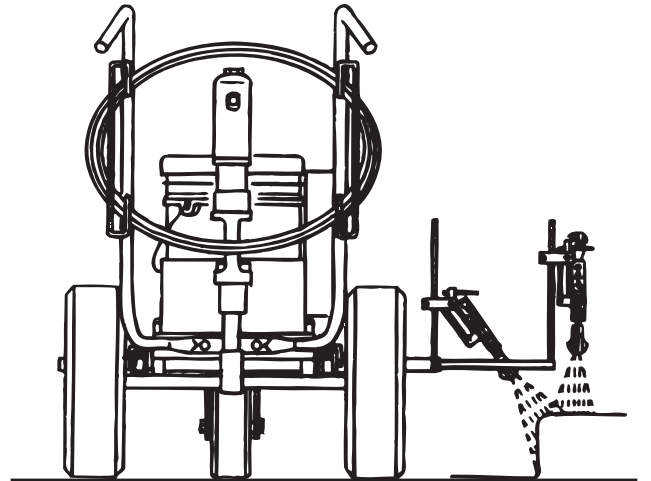

Two Gun Curb

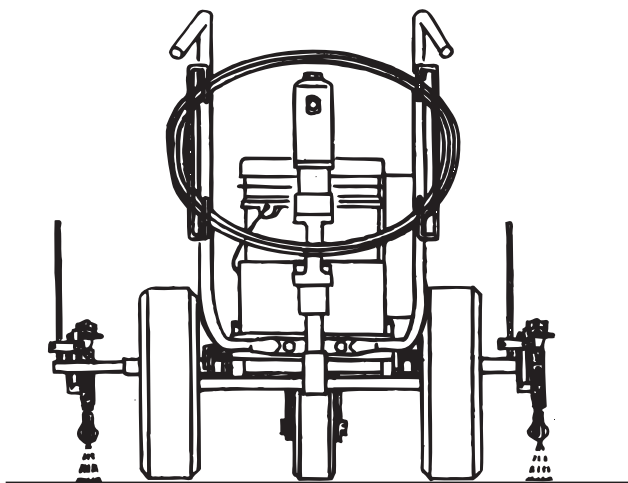

Spraying Around Obstacles

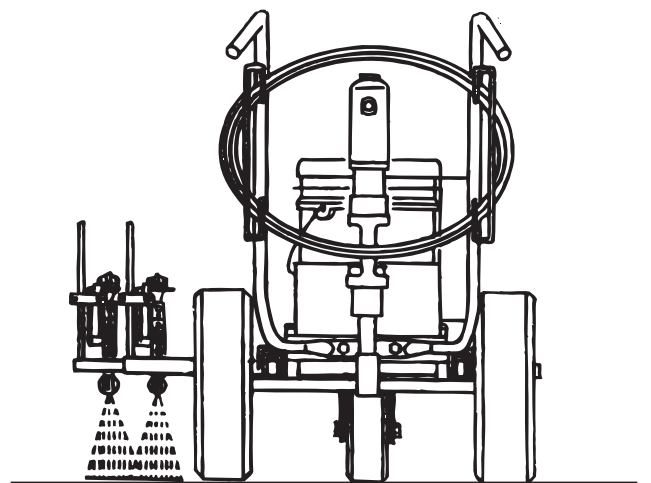

Two Lines or One Wide Line

Warranty

Titan Tool, Inc., ("Titan") warrants that at the time of delivery to the original purchaser for use ("End User"), the equipment covered by this warranty is free from defects in material and workmanship. With the exception of any special, limited, or extended warranty published by Titan, Titan's obligation under this warranty is limited to replacing or repairing without charge those parts which, to Titan's reasonable satisfaction, are shown to be defective within twelve (12) months after sale to the End User. This warranty applies only when the unit is installed and operated in accordance with the recommendations and instructions of Titan.

This warranty does not apply in the case of damage or wear caused by abrasion, corrosion or misuse, negligence, accident, faulty installation, substitution of non-Titan component parts, or tampering with the unit in a manner to impair normal operation.

Defective parts are to be returned to an authorized Titan sales/service outlet. All transportation charges, including return to the factory, if necessary, are to be borne and prepaid by the End User. Repaired or replaced equipment will be returned to the End User transportation prepaid.

THERE IS NO OTHER EXPRESS WARRANTY. TITAN HEREBY DISCLAIMS ANY AND ALL IMPLIED WARRANTIES INCLUDING, BUT NOT LIMITED TO, THOSE OF MERCHANTABILITY AND FITNESS FOR A PARTICULAR PURPOSE, TO THE EXTENT PERMITTED BY LAW. THE DURATION OF ANY IMPLIED WARRANTIES WHICH CANNOT BE DISCLAIMED IS LIMITED TO THE TIME PERIOD SPECIFIED IN THE EXPRESS WARRANTY. IN NO CASE SHALL TITAN LIABILITY EXCEED THE AMOUNT OF THE PURCHASE PRICE. LIABILITY FOR CONSEQUENTIAL, INCIDENTAL OR SPECIAL DAMAGES UNDER ANY AND ALL WARRANTIES IS EXCLUDED TO THE EXTENT PERMITTED BY LAW.

TITAN MAKES NO WARRANTY AND DISCLAIMS ALL IMPLIED WARRANTIES OF MERCHANTABILITY AND FITNESS FOR A PARTICULAR PURPOSE WITH RESPECT TO ACCESSORIES, EQUIPMENT, MATERIALS OR COMPONENTS SOLD BUT NOT MANUFACTURED BY TITAN. THOSE ITEMS SOLD, BUT NOT MANUFACTURED BY TITAN (SUCH AS GAS ENGINES, SWITCHES, HOSES, ETC.) ARE SUBJECT TO THE WARRANTY, IF ANY, OF THEIR MANUFACTURER. TITAN WILL PROVIDE THE PURCHASER WITH REASONABLE ASSISTANCE IN MAKING ANY CLAIM FOR BREACH OF THESE WARRANTIES.

Patents

These products are covered by one or more of the following U.S. patents:

5,947,381 5,749,528 5,660,332 5,425,506 4,611,758 4,508,268

Material Safety Data Sheets (MSDS) are available on Titan's website or by calling Customer Service.



United States Sales & Service

1-800-526-5362

Fax 1-800-528-4826

107 Bauer Drive
Oakland, NJ 07436

www.titantool.com

Canadian Branch

1-800-565-8665

Fax 1-905-856-8496

200 Trowers Road, Unit 7B
Woodbridge, Ontario L4L 5Z8

International

1-201-337-1240

Fax 1-201-405-7449

107 Bauer Drive
Oakland, NJ 07436 USA