

QSR-502 & 503 RECIPROCATING AIR MOTORS

IMPORTANT: Read and follow all instructions and Safety Precautions before using this equipment. Keep for future reference.

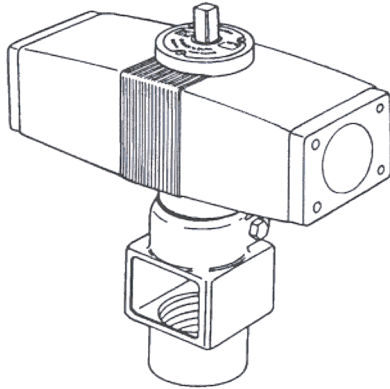

DESCRIPTION

This reciprocating air motor is used to drive material agitators used with pressure feed tanks. Agitator paddle(s) oscillates back and forth in a 180 arc. Air motor speed should be regulated according to the nature of the material to be agitated.

SPECIFICATIONS

Performance data with 60 pounds air pressure when agitating a liquid of 120 seconds viscosity No. 4 Ford cup.	Speed - Oscillations per Minute	Approximate Air Consumption
	20	1.0 cfm
	30	1.5 cfm
	40	3.0 cfm

Maximum Operating Pressure 100 psi

INSTALLATION

Air supply to the motor should be moisture free. Install a separator in the supply line if necessary. See "Accessory Items" for suggested separator.

Where stratification is encountered as with heavy, fast settling materials, it is suggested that the stationary paddle be removed from the fluid of 10 and 15 gallon tanks.

When adjusting slow settling materials, it is not necessary to adjust the paddle position.

To Install Air Motor Assembly on Agitator

For QSR-502

- 1 Screw support (40) of air motor assembly onto agitator shaft bearing housing on tank lid.

- 2 Tighten setscrew (33)

Note

It might be necessary to loosen cap screw (39) in order to get air motor in proper position for attaching hose.

For QSR-503

- 1 Slide air motor drive assembly support (40A) onto bearing assembly so that the agitator shaft engages into the air motor.

Note

It might be necessary to rotate air motor drive assembly in order to get agitator shaft to engage. Once engaged, rotate air motor drive assembly until air motor inlet port is positioned towards back of tank for attaching hose.

- 2 Tighten hex head cap screw (39).

Connect Air Hoses:

For Tanks with No Regulation - Proceed as Follow: QSR-503 Only:

- 1 Remove air inlet valve from service tee on tank and install service tee (64) in its place.
- 2 Reinstall air inlet valve in service tee (63).
- 3 Install nipple (2) in service tee (63) followed by hose assembly (62).
- 4 Connect other end of hose assembly (62) to air inlet on banjo assembly (8).

For Tanks with Single, Double, and Extra-sensitive Regulation - Proceed as Follows (QSR-503 Only):

- 1 Remove air inlet valve from regulator on tank and install service tee (63) in regulator.
- 2 Reinstall air inlet valve in service tee (63).
- 3 Install nipple (2) in service tee (63) followed hose assembly (62).
- 4 Connect other end of hose assembly (62) to air inlet in banjo (8).

For Tanks with Single & Extra-Sensitive Regulation: Proceed as Follows (QSR-502):

- 1 Remove inlet valve on air regulator and install service tee (1).
- 2 Reinstall inlet valve in service tee.
- 3 Install shoulder bushing (2) in service tee (1) followed by air valve (3) and hose assembly (4).
- 4 Connect other end of hose assembly (4) to air in on banjo assembly (8).

For Tanks with Double Regulation-Proceed as Follow (QSR-502):

- 1 Remove plug on side of lower regulator and ins air valve (3).
- 2 Connect air valve (3) to inlet on banjo assembly with hose assembly (4).

OPERATION

To operate air motor, open air valve (3). Then adjust knob (11) to desired speed. Run air motor only fast enough to sufficiently agitate material.

Note

Adjust knob (11) is used as an on-off control and speed adjustment for the QSR-503 Model.

A hand crank can be attached to squared extension of pinion (52) for manual operation. Turn crank back and forth in a half circle. Do not force crank beyond a 180 arc.

To avoid possible personal injury, the hand crank must be removed from the air motor before applying operating air.

PREVENTIVE MAINTENANCE

After approximately 100 hours of operation, disconnect hose assembly at banjo assembly (8) and inject two or three drops of light oil into the air motor.

A line type oiler may be added to the air inlet to maintain uniform lubrication.

After approximately 1000 hours of operation, pinion (52) and piston assembly (41) should be removed and cleaned. When reassembling, lubricate pinion (52), cup washers (46), and rack section of piston assembly (41) with one or two ounces of good grade bearing or gear grease.

QSR-502 & 503 Reciprocating Air Motor Exploded View

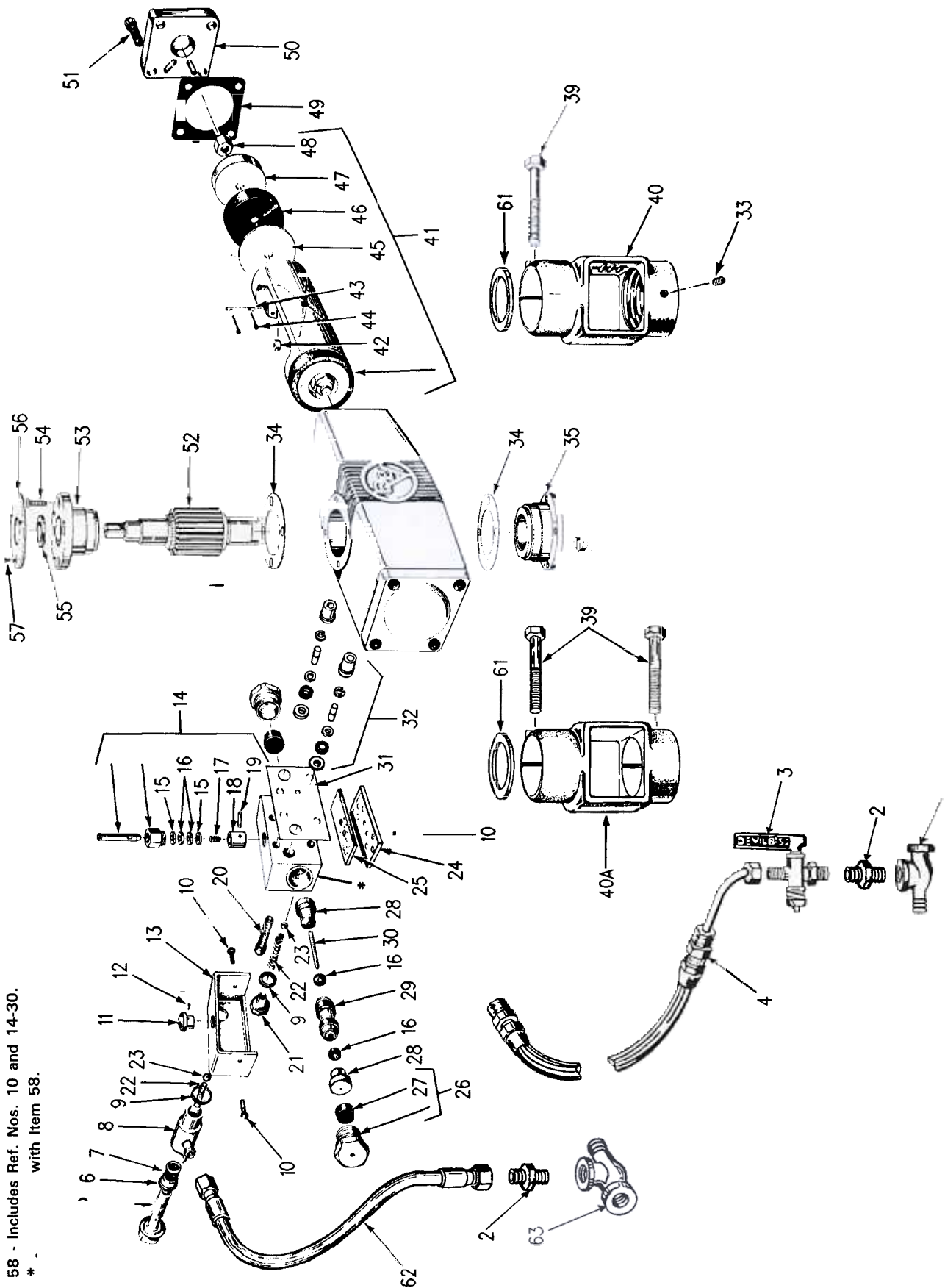

59 - Includes Ref. Nos. 5-32 and 34-38 and 41.
58 - Includes Ref. Nos. 10 and 14-30.
* with Item 58.

Replacement Parts for QSR-502 and 503

Ref No.	Part No.	Description	Individual Parts Req.
1	23425-282	Service Tee 1/4"	1
2	H-2008	Nipple	2
3	P-H-87	Air Valve 1/4" NPT (M) x 1/4" NPS (M)	1
4	P-H-5359	Hose Assy. 1/4" NPS (F) x 1/4" NPS (F)	1
5	33384-120	Filter Screw	1
6	38237-120	Rubber Washer	1
7	41771-013	Filter	1
8	41372-513	Banjo Assembly	1
9	AGA-33-K6	Gasket (Kit of 6)	2
10	2235-225	Screw	4
11	33815-112	Knob	1
12	22311 -021	Screw	1
13	37732-413	Valve Cover	1
14	44122-021	Regulator Screw Assy.	1
15	32213-122	Brass Washer	2
16	38223-119	Washer	4
17	31221-121	Spring	1
18	32411-118	Ring	1
19	22313-042	Screw	1
20	22416-007	Screw	4
21	33384-121	Plug	1
22	31246-117	Spring	2
23	SS-1555	Hard Steel Ball 5/16" Dia.	2
24	36711-103	Silencer Plate	1
25	38512-114	Silencer	1
26	45578-024	Valve Cylinder Plug	2
27	38213-117	Rubber Plug Insert	2
28	33122-122	Valve Cap	2
29	42825-001	Piston	1
30	32132-114	Piston Rod	1
31	38512-113	Valve Gasket	1
32	KK-4136	Service Kit	1
33	SS-399	Setscrew 1/4" x 3/8"	1
34	38245-112	Adapter Gasket	2
35	42542-102	Bottom Bearing Housing Assy.	1
36	33475-117	Coupling	1
37	38244-129	Washer	1
38	33465-104	Adapter	1
39	SS-29-CD	Hex Hd. Cap Screw 3/8"-16x2"	1
40	QS-70-2	Support for QSR-502	1
40A	QMS-35	Support for QSR-503	1
41	45855-802	Piston Assy.	1
42	32212-130	Roller	2
43	32125-126	Pin	2
44	21126-381	Cotter Pin 1/16" Dia. x 1/2" Long	4
45	32244-119	Washer	2
46	SSG-4501	Cup Washer	2
47	32415-116	Piston Washer	2
48	22486-323	Lock Nut 3/8"	2
49	38533-120	End Cap Gasket	2
50	37732-111	End Cap	2
51	22416-023	Screw	8
52	31441-208	Pinion	1
53	42542-101	Top Bearing Housing	1
54	22417-004	Screw	4
55	38243-130	Felt Washer	1
56	31861-406	Nameplate	1
57	21264-901	Screw	3
58	44181-003	Valve Assy.	1
59	QSR-402	Reciprocation Air Motor	1
60	22416-182	Screw	4
61	32243-133	Washer	1
62	HA-57011	Hose Assy. 1/4" NPS(F) x 1/4" NPS(F)	1
63	23425-282	Service Tee 1/4" NPT	1

These Parts Should Be Kept On Hand For Service Convenience

Ref No.	Part No.	Description	Individual Parts Req.
6	38237-120	Rubber Washer	1
7	41771-013	Filter	1
9	AGA-33-K6	Gasket (Kit of 6)	2
16	38223-119	Washer	4
17	31221-121	Spring	1
22	31246-117	Spring	2
29	42825-001	Piston	1
31	38512-113	Valve Gasket	1
32	KK-4136	Service Kit	1
34	38245-112	Adapter Gasket	2
37	38244-129	Washer	1
42	32212-130	Roller	2
43	32125-126	Pin	2
46	SSG-4501	Cup Washer	2
49	38533-120	End Cap Gasket	2
55	38243-130	Felt Washer	1

SERVICE CHECKS

CONDITION	CAUSE	CORRECTION
A. Motor sluggish or inefficient.	1. Motor (59) needs cleaning. 2. Filter (7) clogged. 3. Cup washers (46) worn or damaged. 4. Piston (29) worn or damaged.	1. See Preventive Maintenance section. 2. Clean with solvent or replace. 3. Replace. 4. Replace.

SERVICE BULLETIN REVISIONS

Refer to the following chart for Part No./Literature changes.

Part No. Changes			Literature Changes
Old Part No.	New Part No.	Interchangeability	
SS-11972 Service Tee 3/8"	23425-282 Service Tee 1/4"	Directly	

Worldwide Sales and Service - www.devilbiss.com

DeVilbiss Industrial Spray Equipment

DeVilbiss has authorized distributors throughout the world. **FOR TECHNICAL ASSISTANCE OR THE DISTRIBUTOR NEAREST YOU, CALL TOLL FREE 1-800-338-4448 (U.S.A. AND CANADA ONLY).** For local calls, see listing below.

U.S./Canada Sales & Customer Service

Address

Telephone No.

MAUMEE, OH 43537

1724 Indian Wood Circle

General Inquiry (419) 891-8200
Toll Free Fax No.1-800-338-0131



An Illinois Tool Works Company

7/99 © Copyright 1999, DeVilbiss

Printed in U.S.A.