



## Model MAX-504 Ultra Efficient Ergonomically Designed Spray Gun (Spray Pistol)

**IMPORTANT:** Before using this equipment, read all safety precautions and instructions. Keep for future use.

### TABLE OF CONTENTS

|  | Page # |
|--|--------|
| Description.....                                   | 1      |
| Specifications.....                                | 1      |
| Installation.....                                  | 1      |
| Safety Precautions.....                            | 2      |
| Operation.....                                     | 4      |
| Fluid Control Knob.....                            | 4      |
| Horn Air Control Knob.....                         | 4      |
| Spray Pattern.....                                 | 4      |
| Adjustments.....                                   | 4      |
| Cleaning.....                                      | 4      |
| Periodic Maintenance.....                          | 5      |
| Lubrication Points.....                            | 5      |
| Replacement of Parts.....                          | 5      |
| Replacement Procedures.....                        | 5      |
| Air Cap.....                                       | 5      |
| Fluid Head and Needle.....                         | 5      |
| Gun Grips.....                                     | 6      |
| Air Valve Bushing, Seal, Piston, and Air Seal..... | 6      |
| Horn Air Control Knob.....                         | 10     |
| Primary Trigger.....                               | 10     |
| T-Block and Actuator.....                          | 10     |
| Fluid Tube Assembly.....                           | 11     |
| Air Fitting.....                                   | 11     |
| Air Cap Seal.....                                  | 12     |
| Fluid Head Retaining Ring.....                     | 12     |
| KK-5054 Gun Repair Kit.....                        | 7      |
| Spray Gun (spray pistol) Exploded View.....        | 8      |
| Parts Listing.....                                 | 9      |
| Troubleshooting & Service Checks.....              | 13     |
| Warranty.....                                      | 15     |
| Accessories.....                                   | 16     |
| Worldwide Sales & Service.....                     | 16     |

Products shown here are covered by one or more of the following U.S. Patent Nos. 5,236,129, 5,289,974, 5,330,108, 5,332,156, 5,332,159, D351,895, D349,559, 5,395,094 & 5,711,485. Foreign patents are issued or pending.

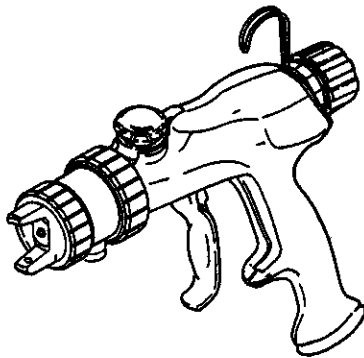

Figure 1

### DESCRIPTION

Model: MAX-504

The patented MAX-504 spray gun is an ultra efficient, ergonomically designed, spray gun intended for professional use. It uses low atomization pressure to spray most general purpose coatings and is suited for high production applications. The gun is intended for use with a pressure feed paint supply.

The MAX-504 weighs only 12 ounces (340 g). The handle grip is contoured to fit the palm. The primary trigger requires less than 2 pounds (908 g) of force to pull, and the pneumatic trigger less than 1 pound (454 g).

### SPECIFICATIONS

|                                      |                           |
|--------------------------------------|---------------------------|
| Air Inlet:                           | 1/4"                      |
| Fluid Inlet:                         | 3/8"                      |
| Body:                                | Engineered Resins*        |
| Wetted Parts:                        | Engineered Resins* & S.S. |
| Weight:                              | 12 ounces (340 g)         |
| Fluid Delivery:                      | Pressure Feed             |
| Max. Fluid Temp.                     | 40°C                      |
| P-1 - Maximum Air Pressure:          | 100 PSI (7 bar)           |
| P-2 - Maximum Fluid Pressure:        | 150 PSI (10 bar)          |
| Air Consumption at 10 PSI Cap Press. | 22.5 CFM (48MP)           |
| Trigger Force:                       |                           |
| Primary                              | < 2 lbs. (908 g)          |
| Pneumatic                            | < 1 lb. (454 g)           |

\*A list of materials used in the construction of this equipment is available upon request.

### INSTALLATION

Attach air hose to 1/4" fitting at base of gun handle. Use two wrenches to tighten. Attach fluid hose to 3/8" fitting on end of 4 ft. fluid hose, using "S" clip as shown in Figure 2.

A means of regulating both fluid and air pressures must be provided so that operation of the spray gun can be properly controlled. Inlet air pressure (measured at the gun) of approximately 65 PSI (4.4 bar) will result in approximately 10 PSI (.6 bar) at the air cap. Actual air cap pressure should be measured with an air cap test kit (see Accessories) to confirm 10 PSI (.6 bar) or less to meet air quality regulations.

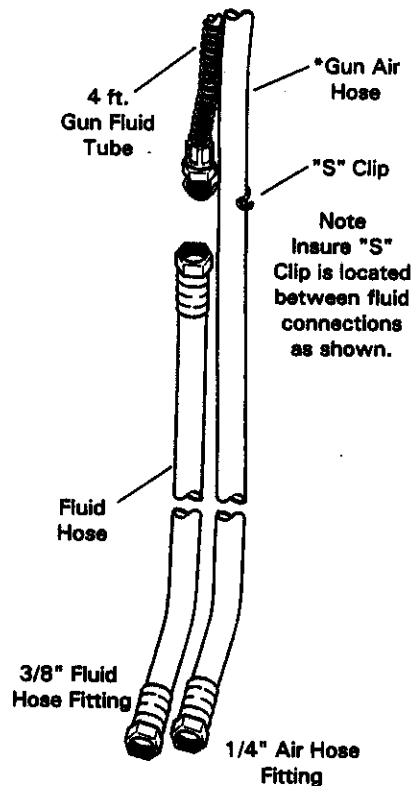

Figure 2 \*H-3670 Ergoflex™ 3/8" flexible air hose recommended (purchase separately).

**SAFETY PRECAUTIONS**

This manual contains information that is important for you to know and understand. This information relates to **USER SAFETY** and **PREVENTING EQUIPMENT PROBLEMS**. To help you recognize this information, we use the following symbols. Please pay particular attention to these sections.



**Important safety information - A hazard that may cause serious injury or loss of life.**





**Important information that tells how to prevent damage to equipment, or how to avoid a situation that may cause minor injury.**

**Note**

**You should pay special attention to this information.**



**The following hazards may occur during the normal use of this equipment. Please read the following chart before using this equipment.**

| Hazard   | Cause  | Safeguards  |
|--|--|---|
| <p><b>Fire</b></p>   | <p>Solvents and coatings can be highly flammable or combustible especially when sprayed.</p>   | <p>Adequate exhaust must be provided to keep air free of accumulations of flammable vapors.</p> <p>Smoking must never be allowed in the spray area.</p> <p>Fire extinguishing equipment must be present in the spray area.</p> <p>Static discharges must be prevented. Ground all conductive objects in the spray area, such as cleaning solvent bucket, fire extinguisher, etc.</p> <p>When using solvents for cleaning:</p> <ul style="list-style-type: none"> <li>• Those used for equipment flushing must have a flash point equal to or higher than that of the coating.</li> <li>• Those used for general cleaning must have flash points above 100° F (37.8 C).</li> </ul> |
| <p><b>Inhaling Toxic Substances</b></p>                  | <p>Certain materials may be harmful if inhaled, or if there is contact with the skin.</p>  | <p>Follow the requirements of the Material Safety Data Sheet supplied by your coating material manufacturer.</p> <p>Adequate exhaust must be provided to keep the air free of accumulations of toxic materials.</p> <p>Use a mask or respirator whenever there is a chance of inhaling sprayed materials. The mask must be compatible with the material being sprayed and its concentration. Equipment must be as prescribed by an industrial hygienist or safety expert, and be NIOSH approved.</p>  |
| <p><b>Explosion Hazard - Incompatible Materials</b></p>  | <p>Halogenated hydrocarbon solvents - for example; methylene chloride and 1, 1, 1-h are not chemically compatible with the aluminum that might be used in many system components. The chemical reaction caused by these solvents reacting with aluminum can become violent and lead to an equipment explosion.</p> | <p>The MAX-504 HVLP Paint Spray Gun can be used with these solvents. However, aluminum is widely used in other spray application equipment, such as material pumps, cups and regulators, valves, etc. Check all equipment items before use and make sure they can also be used safely with these solvents. Read the label or data sheet for the material you intend to spray. If in doubt as to whether or not a coating or cleaning material is compatible, contact your material supplier.</p>  |

## SAFETY PRECAUTIONS (continued)

| Hazard  | Cause   | Safeguards   |
|---|---|--|
| <b>General Safety</b>   | Improper operation or maintenance of equipment.   | Operators should be given adequate training in the safe use and maintenance of the equipment (in accordance with the requirements of NFPA-33, Chapter 15 in U.S.). User must comply with all local and national codes of practice and insurance company requirements governing ventilation, fire precautions, operation, maintenance and housekeeping. In the U.S., these are OSHA Sections 1910.94 and 1910.107 and NFPA-33).   |
| <b>Noise Levels</b><br>- Ear Injury<br>  | A continuous A-weighted sound pressure level of this spray gun may exceed 85 dB(A) depending on the air cap/spray head setup being used. Sound levels are measured using an impulse sound level meter and analyzer, when the gun is being used in a normal spraying application.  | Always wear ear protection when using the gun.<br><br>Details of actual noise levels produced by the various air cap/spray head setups are available upon request.   |
| <b>Misuse</b> <ul style="list-style-type: none"> <li>• All spray guns project particles at high velocity and must never be aimed at any part of the body.</li> <li>• Never exceed the recommended safe working pressures for any of the equipment used.</li> <li>• The fitting of non-recommended or non-original accessories or spare parts may create hazardous conditions.</li> <li>• Before dismantling the equipment for cleaning or maintenance all pressure, air and materials, must be isolated and released.</li> </ul> <p>The disposal of waste materials must be carried out in an approved manner. Burning may generate toxic fumes. The removal of waste solvents and coating materials should be carried out by an authorized local waste disposal service.</p> |   |  |
| <b>Cumulative Trauma Disorders (CTD's)</b><br><br>"CTD'S", or musculo-skeletal disorders, involve damage to the hands, wrist, elbows, shoulders, neck & back. Carpal tunnel syndrome and tendinitis (such as tennis elbow or rotator cuff syndrome) are examples of CTD's.  | Use of hand tools may cause cumulative trauma disorders (CTD's).<br><br>CTD's, when using hand tools, tend to affect the upper extremities. Factors which may increase the risk of developing a CTD include: <ol style="list-style-type: none"> <li>1. High frequency of the activity.</li> <li>2. Excessive force, such as gripping, pinching, or pressing with the hands and fingers.</li> <li>3. Extreme or awkward finger, wrist or arm positions.</li> <li>4. Excessive duration of the activity.</li> <li>5. Tool vibration.</li> <li>6. Repeated pressure on a body part.</li> <li>7. Working in cold temperatures.</li> </ol> CTD's can also be caused by such activities as sewing, golf, tennis and bowling, to name a few. | Risk is reduced by avoiding or lessening factors 1-7.<br><br>Pain, tingling, or numbness in the shoulder, forearm, wrist, hands or fingers, especially during the night, may be early symptoms of a CTD. Do not ignore them. Should you experience any such symptoms, see a physician immediately. Other early symptoms may include vague discomfort in the hand, loss of manual dexterity, and nonspecific pain in the arm. Ignoring early symptoms and continued repetitive use of the arm, wrist and hand can lead to serious disability. |

**OPERATION**

The fluid control knob and orifice size of the spray tip control the volume of fluid flow. The horn air control knob (fan) provides full pattern control, from a round pattern to a full fan pattern.

**Fluid Control Knob**



**WARNING**

Risk of eye injury. Always wear eye protection and point the spray gun in a safe direction when adjusting the fluid control.



**WARNING**

Do not turn the fluid control knob out (counterclockwise) more than 1-1/2 to 2 full turns, enough to achieve full fluid flow. If the fluid control is turned out too far, the gun will actuate and spray. This can cause injury to the operator or other personnel within range of the gun outlet if the gun is accidentally triggered.

The fluid control knob, Figure 3, is located on the back of the gun handle. Turn it counterclockwise (outward) to increase fluid flow, and clockwise (inward) to decrease or shut off fluid flow. Full fluid flow is achieved at about 1-1/2 to 2 turns out. If you continue to turn the fluid control knob past the full flow point, you will hear and feel air bleed off from the hole in the fluid control knob. This warning feature, an air leak or hissing sound, indicates the knob is turned outwards too far. Turn the knob inward (clockwise) until the air leak stops. If the fluid control knob is turned outward too far, the gun will engage and spray.

Figure 3

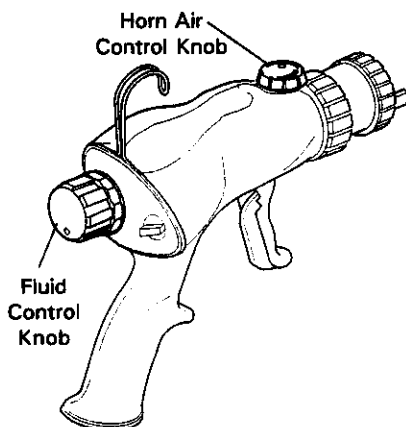

**Horn Air Control Knob**

The horn air control knob is located on top of the gun body, Figure 3. It rotates 90° from full on to full off. Within the 90° rotation, the fan pattern will change from a round pattern to a full fan pattern. To increase horn air flow and widen the spray pattern, rotate the knob counterclockwise. To reduce the fan width or for round spray, rotate clockwise.

Limit fan spray pattern to only as wide as necessary. A wider spray pattern than necessary can result in wasted paint.

**Spray Pattern**

The spray pattern can be changed from a vertical fan to a horizontal fan by loosening the air cap retaining ring and rotating the air cap 90°, Figure 4.

Figure 4

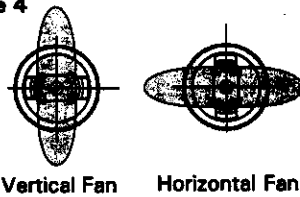

**Triggering Modes**

Figure 5

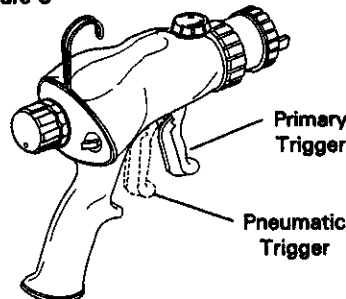

**For Primary Trigger Use** - rotate trigger forward approximately 20° and pull downward.

**For Pneumatic Trigger Use** - rotate trigger forward approximately 20° and push upward. Note a minimum of approximately 6 psi air cap pressure is required for pneumatic trigger function.

With the gun triggered on adjust the regulated air supply to the gun to provide the desired air pressure at the air cap. Confirm air cap pressure with an air cap test kit (see Accessories). Do not use more pressure than is necessary to atomize the material being applied. Adjust regulated fluid pressure to deliver the desired paint volume (refer to following note). Adjust air pressure to provide a uniform dispersion of atomized paint throughout the pattern. Excessive flow rates will result in heavy center spray patterns. Inadequate flows may cause the pattern to split. HVLP requires that a gun distance of 6-8 inches (150-200 mm) be used. Excess distance will produce inferior results.

**Note**

With the "Maximum Performer" spray head and air cap configuration, back pressure is created against the fluid column. For example, at 10 PSI (.7 bar) cap pressure, there is approximately 2.5 PSI (.2 bar) back pressure with the 46MP air cap. This will reduce fluid output, and the fluid regulator will require a slight increase to offset the back pressure.

**Note**

If local or national legislation exists prohibiting the use of air cap pressures greater than 10 PSI (0.7 bar), the air cap test kit (see Accessories) must be used to set the air cap pressure.

**Note**

The spray gun should be cleaned in accordance with local or national legislation applicable to the industry sector in which the equipment is being used.

**CLEANING**

**Note**

Use normal cleaning procedures to clean the MAX-504 spray gun. It should not be necessary to remove the spray head or fluid tube to clean the gun internally. As with all spray guns, soaking the gun is not recommended, as this removes lubrication and can affect performance.

Disconnect the fluid supply hose at the fluid source and attach cleaning solvent hose. A SolventSaver® Hose and Gun Cleaner is ideally suited to most effectively clean all fluid passages (see Accessories on Page 16).

To clean air cap, brush exterior with a stiff bristle brush. If necessary to clean air cap holes, use a broom straw or toothpick. Never use a wire or hard implement; this may scratch or burr holes, causing a distorted pattern. If necessary, the air cap assembly may be removed and soaked in solvent. The fluid head can also be removed and soaked in solvent if necessary. See "Fluid Head (6) and Needle (12)" under REPLACEMENT OF PARTS section.

Wipe the exterior of the gun with a damp solvent rag to remove overspray. The grips can be removed and soaked in solvent if necessary. See "Gun Grips (38 and 39)" in REPLACEMENT OF PARTS section.

## PERIODIC MAINTENANCE

At least once a day check and make sure head retaining ring (Figure 5) is tight. A loose ring will cause an air leak and pattern distortion.

## LUBRICATION POINTS

The following parts should be lubricated when assembling the spray gun:

| Ref. # | Description   | Instructions   |
|--------|---------------|--|
| 6      | Fluid Head    | SSL-10 gun lube (2 drops on fluid head threads)  |
| 13     | Needle Spring | Coat ends lightly with pure petroleum jelly (petroleum based grease)   |
| 10/46  | O-Ring        | SSL-10 gun lube  |
| 19     | O-Ring        | SSL-10 gun lube  |
| 26     | O-Ring        | SSL-10 gun lube  |
| 30     | Piston Assy.  | Light coating of pure petroleum jelly (petroleum based grease) on shaft of piston                            |
| 34     | Rear Plug     | SSL-10 Gun Lube (on threads for knob)  |
| 43     | O-Rings       | SSL-10 gun lube  |
| 50     | Skeleton      | Light coating of pure petroleum jelly (petroleum based grease) on inside diameter where piston (30) travels. |

## REPLACEMENT OF PARTS

All repairs should be made on a clean flat surface. Do not clamp parts in a vise. All part need only be hand tight except where specified in the repair procedures. If using pliers or similar tool to free parts, make sure the jaws are padded.

### Replacement Procedures

#### Note

Always remove the gun from the work site for service or repair. Flush gun thoroughly, relieve pressure, and disconnect fluid and air hoses.

### Air Cap (1)

- When installing the air cap assembly, (1, Figure 10), tighten hand tight, do not overtighten. Apply two drops of SSL-10 gun lube onto the fluid head (6) threads before installing the air cap. (Lubrication facilitates removal of air cap after use.)

### Fluid Head (6) and Needle (12)

- Remove fluid control knob (35, Figure 9) by turning counterclockwise. Remove needle spring (13).
- Pull trigger to expose needle (12). Remove needle with needle nose pliers.
- Remove air cap assembly (1) from fluid head (6).
- Loosen head retaining ring (15) by turning clockwise (when facing front of spray gun). Note the ring remains attached to the skeleton.

### CAUTION

If the air cap or head retaining ring become "locked" on due to dried paint, soak the affected area in solvent long enough to soften the paint. Do not use any tools to remove, damage may occur.

- Grasp fluid head (6) firmly and pull straight off from gun body. If there is any difficulty removing, apply a slight wiggling motion to free the fluid end from the fluid tube O-ring (10).

#### Note

The fluid head (6) and needle (12) should be replaced as a set. If replacing the fluid head and needle, be sure to also replace the packing (8) to prevent fluid leakage.

- Remove packing spring (7).
- Remove fluid tube O-ring (10) from fluid tube assembly and install a new O-ring. See following note.

#### Note

The O-ring (10) is made of BUNA-N and will naturally swell from solvent and paint. This provides a tight seal in the fluid head. When removing the fluid head, always replace the O-Ring. Trying to reuse a swollen O-Ring will make reassembly difficult, and could damage the O-Ring, causing a fluid leak. Swollen O-Rings can be removed, allowed to dry and "shrink" to their normal size, and then reused. **DO NOT** reuse if there are any signs of damage.

- Remove baffle seal (11) and replace with a new seal.

- Install the new or cleaned fluid head and needle as follows:
  - Apply a small amount of SSL-10 gun lube to the front tip of the needle (12). Install needle (12) partially into gun body through rear opening. Leave about 1" (25 mm) of needle exposed out the rear of the gun.
  - Apply a small amount of gun lube to O-ring (10).
  - Apply two drops of gun lube to fluid head threads. (Lubrication facilitates removal of part after use.)
  - Slide new packing/spring (7) over end of needle.
  - Place the fluid head against the gun body, ensuring that the fluid head lines up with the fluid tube opening, Figure 6. Firmly push the fluid head over the fluid tube O-ring and against the head retaining ring.

- Turn the head retaining ring (15) counterclockwise to draw the fluid head onto the body. Hand tighten the retaining ring until the fluid head is drawn firmly against the gun body.
- Push the needle in completely. Install the needle spring (13) and screw in the fluid control knob (35). Turn knob completely in clockwise, then back out 1-1/2 to 2 turns for full fluid flow.
- Apply SSL-10 gun lube to the air cap threads. Screw the air cap assembly (1) onto the fluid head (6). Tighten hand tight, do not overtighten.

Figure 6

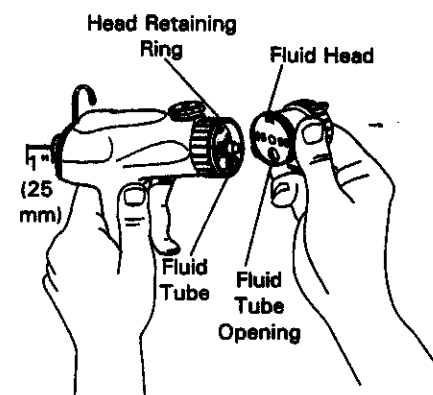

**Gun Grips (38 and 39)**

1. Place 1/4" (6 mm) flat blade screwdriver, Figure 7, and pry upper clip out of groove. Expand the bottom of the clip to remove from the mounting slots.
2. To remove the lower clip (41) from the gun grips, use a pair of external retaining pliers or push down on the clip tabs with your thumbs.

**Figure 7**

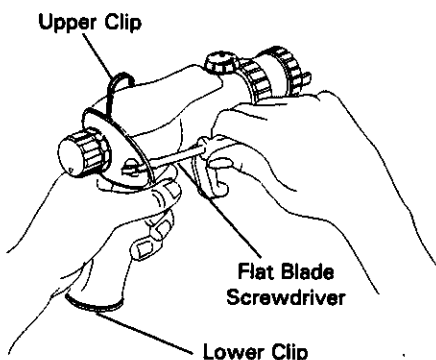

3. Separate grips at handle and top by prying christmas tree clips (37).
4. Pull outward on the back of each grip to disengage the grips from the notch at the front of the body under the fluid head retaining ring (15).
5. To reassembly grips, install right gun grip. Push grip down into position.
6. Install tab on left gun grip (38) into slot under retaining ring and push grip down into position.
7. Push grips together at christmas tree clips (37).
8. Install lower clip (41) and upper clip (40).

**Air Valve Bushing (29), Seal (28), Piston (30), and Air Seal (33) (Parts included in Gun Repair Kit KK-5054)**

**Note**

It is recommended that you use the gun repair kit KK-5054, Figure 9, when undertaking this procedure. Use all parts provided in the kit. Refer to the various procedures in this manual to access all kit parts.

1. Refer to gun grips procedure and remove gun grips (38 and 39, Figure 10).
2. Refer to fluid head and needle assembly procedure and remove head and needle assembly.
3. Remove packing/spring (7), fluid tube O-ring (10), and baffle seal (11).

4. Using a 1-1/16 inch (27 mm) socket or adjustable wrench, unscrew rear plug (34) from gun body.
5. Remove piston return spring (31). Using your finger, push air seal (33) out of rear plug (34).
6. Remove piston assembly (30). You can either remove the piston by striking the back of the gun body against the palm of your hand or by pulling it out with a pair of needle nose pliers.
7. Remove air valve bushing (29) and seal (28). To remove, use a dental pick to catch the center hole, and pull out.
8. (OPTIONAL) Pull out air inlet retainer (24) and remove air inlet plug (25) with O-ring (26).
9. Pull out lower spring clip (44) and remove air fitting (42). Remove O-rings (43) from fitting.

**Note**

When assembling spray gun, lube all sliding parts with pure petroleum jelly (petroleum based grease).

10. Install O-rings (43) into fitting (42), the lower groove is for lower spring clip. Lubricate O-rings (43) and slide fitting into skeleton.
11. Push on fitting until you can see light through the lower spring clip hole and install lower spring clip (44) into skeleton. Install spring clip into gun body from the left hand side.
12. Apply a thin film of pure petroleum jelly (petroleum based grease) to inside diameter of the skeleton (50) and outer surface of piston shaft (30). Install piston assembly (30) into air valve bushing (29). Slide U-cup seal (28), grooved end towards bushing, onto piston shaft.
13. Install assembled air valve bushing and piston into gun body. Push in completely.
14. Install air seal (33, Figure 8), tapered end first, into rear plug (34). Install spring (31) into plug.



**Overtightening can damage the plug or gun skeleton. When tightening rear plug into gun body do not overtighten. Snug only.**

15. Push assembled rear plug into back of gun body and thread into gun. Use a 1-1/8 inch (27 mm) socket or crescent wrench to snug rear plug into gun body, do not overtighten.

16. Install baffle seal (11) into face of spray gun body.
17. Install O-ring (10) onto fluid tube (47). Lubricate O-ring with SSL-10 gun lube.
18. Install needle (12) partially into gun body through rear opening, Figure 8. Leave about 1" of needle exposed out rear of gun.
19. Apply two drops of gun lube to fluid head (6) threads. (Lubrication facilitates removal of parts after use.)
20. Place packing/spring (7) on the end of the needle.
21. Place fluid head against gun body, ensuring fluid head lines up with fluid tube opening, Figure 8. Firmly push fluid head over fluid tube O-ring and against head retaining ring.
22. Turn head retaining ring (15) counterclockwise to draw fluid head onto body. Hand tighten head retaining ring until fluid head is drawn firmly against the gun body.
23. Push needle in completely. Install needle spring (13) and screw in fluid control knob (35). Turn knob completely in clockwise, then back out 1-1/2 to 2 turns for full fluid flow.

**Figure 8**

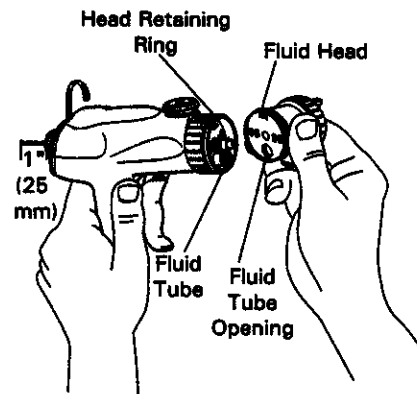

25. Apply SSL-10 gun lube to the air cap threads. Screw the air cap assembly (1) onto the fluid head (6). Tighten hand tight, do not overtighten.
26. Refer to gun grip procedure and install gun grips (38 and 39).

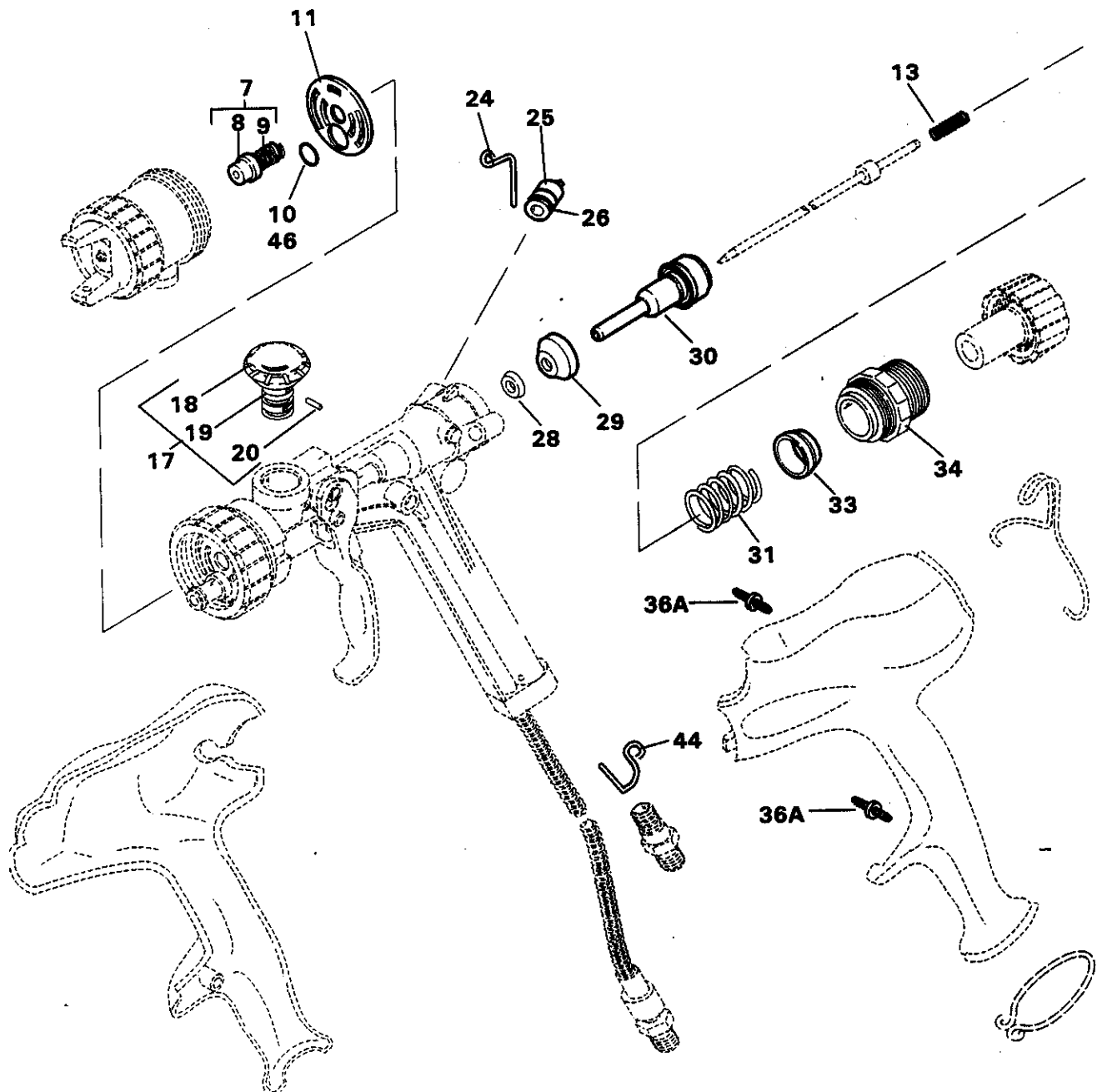

Figure 9 - KK-5054 Repair Kit

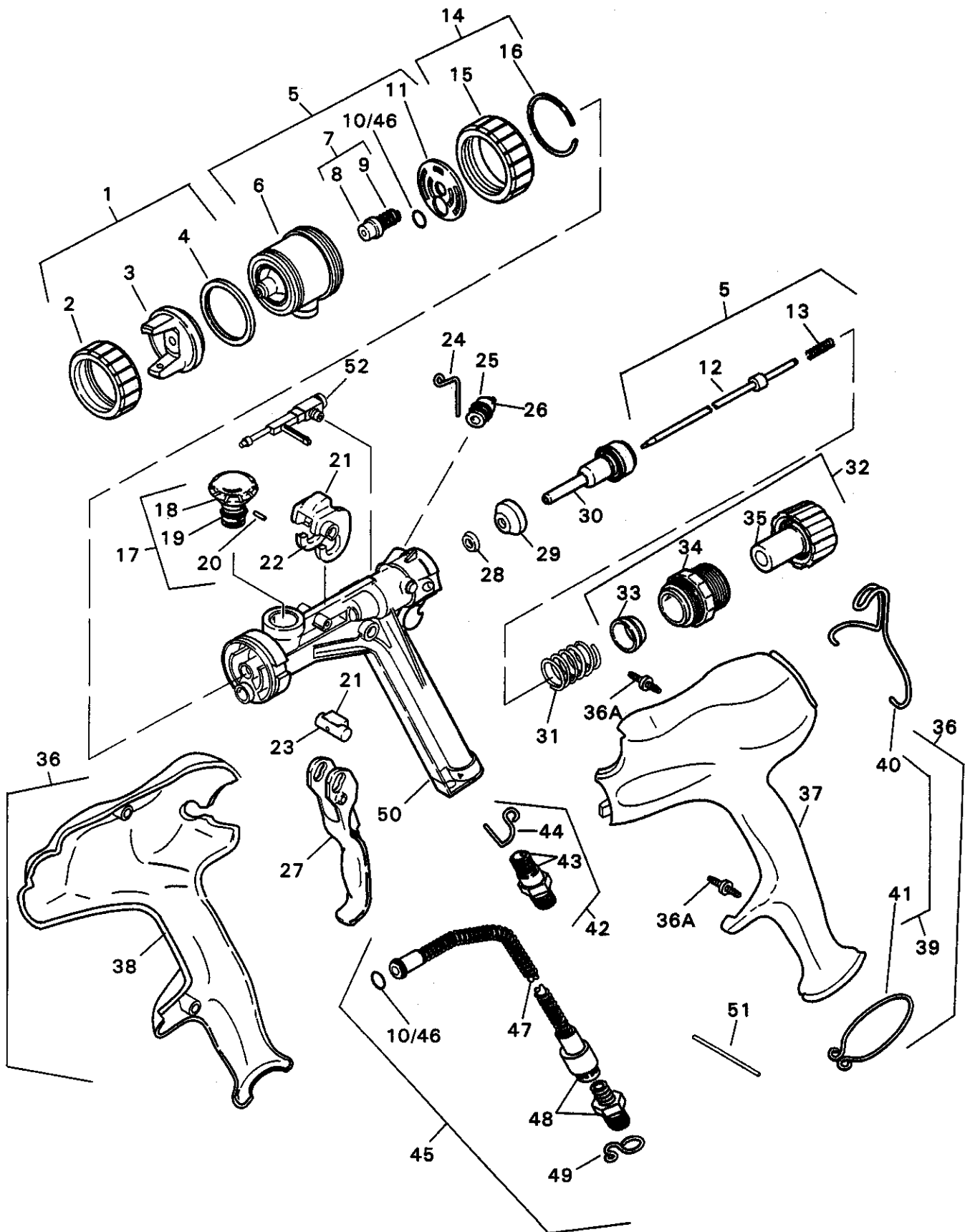

Figure 10 - MAX-504 Spray Gun Exploded View



| Ref. No. | Replacement Part Number      | Description  |
|----------|------------------------------|--|
| 1        | OMX-411-46MP<br>OMX-411-83MP | Air Cap Kit<br>Air Cap Kit                             |
| 2        | OMX-11                       | • Air Cap retaining ring (air cap retaining nut)       |
| 3        | ---                          | • Air Cap 46MP   |
| 4        | OMX-45-K2                    | • Seal Kit (Kit of 2)                                  |
| 5        | OMX-4033                     | Fluid Head and Needle Kit .055" (1.4 mm) (65-10 head)  |
|          | OMX-4034                     | Fluid Head and Needle Kit .042" (1.1 mm) (65-10 head)  |
|          | OMX-4035                     | Fluid Head and Needle Kit .070" (1.8 mm) (65-10 head)  |
|          | OMX-4036                     | Fluid Head and Needle Kit .042" (1.1 mm) (50-10 head)  |
|          | OMX-4037                     | Fluid Head and Needle Kit .055" (1.4 mm) (50-10 head)  |
| 6        | ---                          | • Fluid Head Assembly                                  |
| 7        | OMX-451                      | • Needle Packing Kit (includes 5 packings and springs) |
| 8*       | ---                          | •• Packing   |
| 9*       | ---                          | •• Packing Spring                                      |
| 10*      | SSG-8189-K10                 | Fluid Tube O-ring Kit (Kit of 10)                      |
| 11*      | OMX-48-K5                    | Baffle Seal (Kit of 5)                                 |
| 12       | ---                          | • Needle Assembly                                      |
| 13*      | ---                          | • Needle Spring, Silver                                |
| 14       | OMX-453                      | Head Retaining Ring Kit                                |
| 15       | ---                          | • Head Retaining Ring                                  |
| 16       | ---                          | • Retaining Clip                                       |
| 17*      | OMX-460                      | Horn Air Valve Kit                                     |
| 18       | ---                          | • Horn Air Valve                                       |
| 19       | ---                          | • O-Ring   |
| 20       | ---                          | • Spring Pin   |
| 21       | OMX-489                      | Actuator and T-Block Kit                               |
| 22       | ---                          | • Actuator   |
| 23       | ---                          | • T-Block  |
| 24*      | ---                          | Air Inlet Retainer                                     |
| 25*      | ---                          | Air Inlet Plug   |
| 26*      | ---                          | Air Inlet O-Ring                                       |
| 27       | OMX-150                      | Primary Trigger  |
| 28*      | ---                          | Seal   |
| 29*      | ---                          | Air Valve Bushing                                      |
| 30*      | ---                          | Piston Assembly  |
| 31*      | ---                          | Piston Return Spring                                   |
| 32       | OMX-481                      | Rear Plug, Seal & Fluid Knob Kit                       |

| Ref. No. | Replacement Part Number | Description   |
|----------|-------------------------|---|
| 33*      | ---                     | • Air Seal  |
| 34*      | ---                     | • Rear Plug   |
| 35       | ---                     | • Fluid Control Knob  |
| 36       | OMX-488                 | Gun Grip Kit (includes Items 37, 38, 39, 40, 41)                |
| 36A      | SSN-8002-K10            | Christmas Tree Clip Kit 2 used (Kit includes 10)                |
| 37       | ---                     | • Overgrip, Left  |
| 38       | ---                     | • Overgrip, Right   |
| 39       | OMX-494                 | Grip Clip Kit   |
| 40       | ---                     | •• Upper Clip   |
| 41       | ---                     | •• Lower Clip   |
| 42       | OMX-468                 | Air Inlet Kit   |
| 43       | ---                     | • O-Rings (2)   |
| 44*      | ---                     | • Lower Spring Clip   |
| 45       | OMX-4023                | 4' (1.4 m) Spring Guard Fluid Tube Assy. Kit                    |
| 46*      | ---                     | • Fluid Tube O-Ring   |
| 47       | OMX-404                 | • Fluid Tube Assembly   |
| 48       | OMX-482                 | • 3/8" Tube Connector Kit (5 in Kit) (1 in Ref. 45 and 47 Kits) |
| 49       | ---                     | • "S" Hose Clip   |
| 50       | OMX-4027                | Skeleton Assembly   |
| 51       | ---                     | Pin Removal Tool (included with Ref. No. 17)                    |
| 52       | OMX-428-K2              | Pneumatic Trigger Module (Kit of 2)                             |

\* Parts included in Repair Kit KK-5054. Refer to Figure 9.  
Notes: Items 10 and 46 are the same part. This part has been shown in 2 locations to show the relationship to parts kits.

**Horn Air Control Knob (18)**

1. Refer to gun grips procedure and remove gun grips (38 and 39).
2. Position gun body so that it is supported near the horn air spring pin (20). Use the pin removal tool (51) (supplied with OMX-460 kit), and a small hammer to drive out spring pin (20).
3. Pull horn air valve (18) from gun body. If cleaning horn air valve, remove O-ring (19). After cleaning, install new O-ring in top groove.
4. Install horn air valve (18) so that the rheostat symbol is in the forward right quadrant, Figure 11, when looking down in the gun body with the handle toward you.
5. Push horn air valve down until you can see light through the pin hole, install pin. Position gun body over block to provide support, and carefully drive pin in using a small hammer.
6. Refer to gun grips procedure and install gun grips (38 and 39).

Figure 11

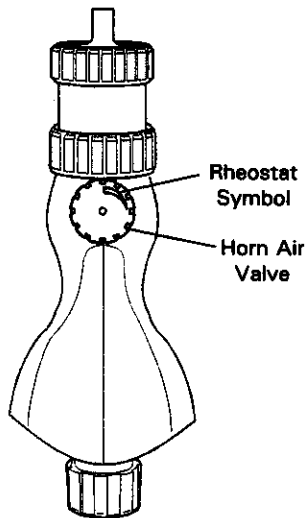

Primary Trigger (27)

**CAUTION**

Primary trigger must be positioned in the full forward position to remove or install. If not positioned full forward the trigger pins will not clear the actuator. The trigger may break if spread too far.

1. Refer to gun grips procedure and remove gun grips (38 and 39).
2. Refer to fluid head and needle assembly procedure and remove needle assembly (12) (needle only) from gun body.
3. Position primary trigger fully forward. Using your fingers or a screwdriver, pry the legs of the trigger far enough to clear the actuator and remove.
4. Assemble new trigger in reverse order.
5. Refer to gun grips procedure and install gun grips (38 and 39).

**"T-Block" (23) and Actuator (22)**

1. Refer to gun grips procedure and remove gun grips (38 and 39).
2. Remove primary trigger (27) (refer to "Primary Trigger" section).
3. To remove T-block (23), carefully lift up on actuator tab and use a small screwdriver to push back on T-block, Figure 12, snapping T-block out of actuator.

Figure 12

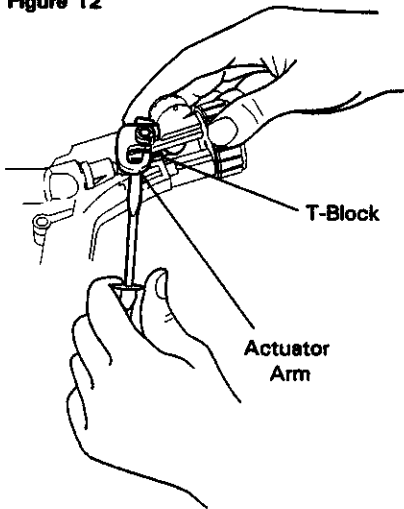

4. To remove actuator (22), wedge a screwdriver between the actuator and horn air valve (see Figure 13). Then, using a pencil or similar tool, pry the actuator back off the skeleton mounting posts as shown.

Figure 13

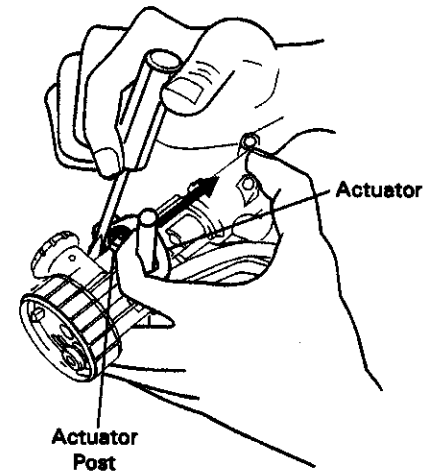

5. Install the new actuator (22) onto the skeleton as shown in Figure 14.

Figure 14

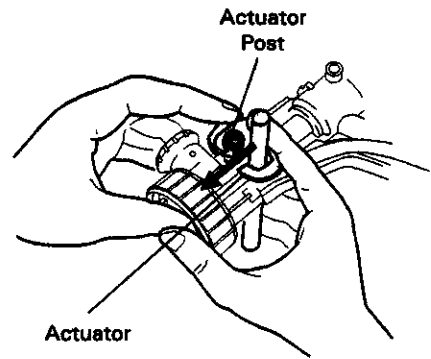

6. To assemble T-block (23) into actuator, the rounded end must be facing forward, Figure 15, toward the spray head. Install T-block into gun body slot in front of actuator with flat edge into the actuator. Use a small screwdriver to push T-block through into actuator arm on opposite side, Figure 16. At that point, flex actuator arm ear out past T-block and push T-block fully into actuator arm, Figure 17.

Figure 15

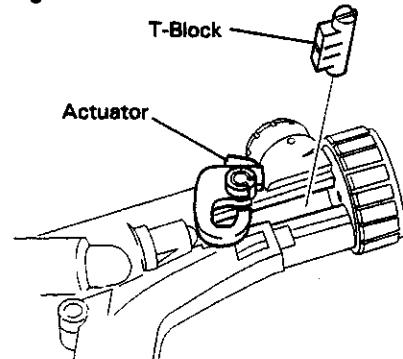

Figure 16

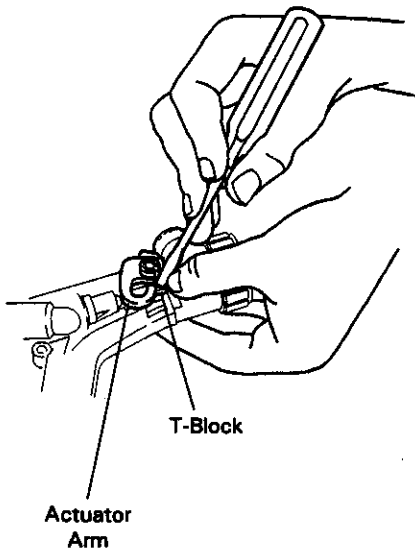
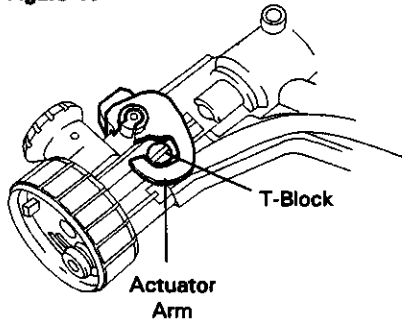

Figure 17



**Pneumatic Trigger Module (52)**

1. Refer to gun grip procedure and remove gun grips (37) and (38).
2. To remove pneumatic trigger module (52), squeeze the retaining bars with a pair of pliers and push towards the skeleton (Figure 18). Pull valve out of skeleton from the opposite side.
3. Install new pneumatic valve (52) by locating valve body into skeleton, then pushing until retaining bars engage on opposite side of skeleton. Lube O-ring with SSL-10 gun lube prior to assembly.
4. Refer to gun grip procedure and install gun grips (37) and (38).

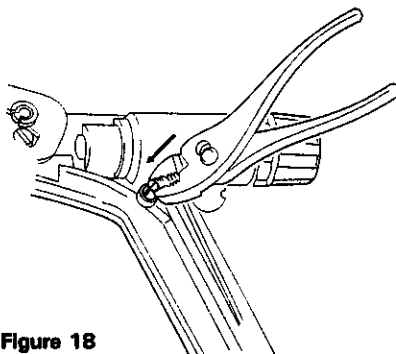
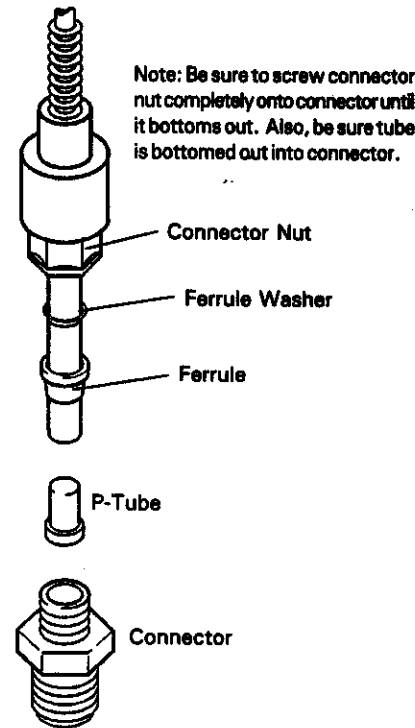

Figure 18

**Fluid Tube and Spring Guard Assembly**

1. Refer to gun grips procedure and remove gun grips (38 and 39).
2. Refer to fluid head and needle assembly procedure and remove head and needle.
3. Remove packing/spring (7).
4. Remove spring retainer and tube connector (48) from fluid tube. Remove connector nut, ferrule, ferrule washer, and P-tube, Figure 19, from fluid tube.
5. Pull fluid tube through loops of spring.

Figure 19



6. Pull fluid tube out from front of gun body, Figure 20.
7. Install fluid tube assembly (47) into round hole at bottom of gun skeleton.

Figure 20

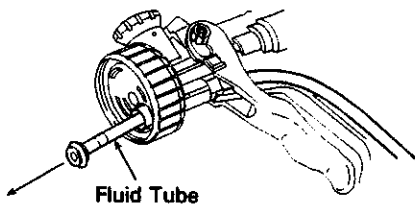

8. Slide kink guard spring over end of fluid tube. Spring should extend approximately 3" into skeleton as shown in illustration. Press spring (requires a little force) into slot at base of skeleton.

Figure 21

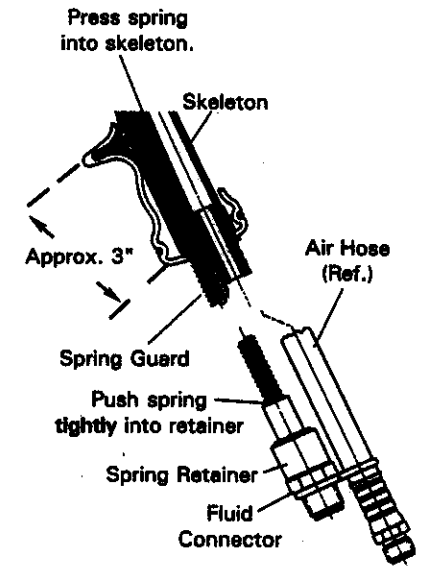

9. Install left and right grips onto gun using grip clips.
10. Compress spring guard on opposite end to expose nylon tube.
11. Slide spring retainer over tube against spring.
12. Assemble fluid connector to tube.
13. Push spring retainer tightly over fluid connector.
14. Push spring into opening of spring retainer with a twisting action. Insert a minimum of 1/2".
15. Install "S" clip to air hose and fluid connector.
16. Install spray head.

**Air Fitting (42)**

1. Refer to gun grips procedure and remove gun grips (38 and 39).
2. Pull lower spring clip (44) from gun body handle, and pull air fitting (42) from gun handle.
3. Install end of air fitting (42) into gun body handle.
4. Push on air fitting until you can see daylight through lower spring clip hole and install lower spring clip (44) into gun body.
5. Refer to gun grips procedure and install gun grips (38 and 39).

### Air Cap Seal

To replace air cap seal, pry out old seal with a small thin bladed screwdriver. With air cap in retaining ring place the seal on outer edge of ring. Use your finger and thumb to push the seal into retaining ring and slip it in place by sliding your finger around the ring, Figure 22.

Figure 22

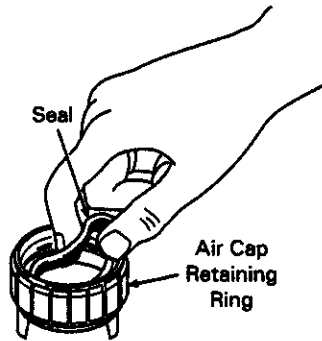

### Fluid Head Retaining Ring

1. Cut the old head retaining ring (15) using wire cutter, and remove from the gun body.
2. Remove and discard the retaining ring clip (16).
3. Position the new retaining ring clip over the retaining ring groove in the head end of the skeleton, Figure 23.
4. Close the clip with one hand, then push the retaining ring back until it slides over the clip and snaps in place. When properly secured, the head retaining ring is captive and cannot be pulled off the skeleton.



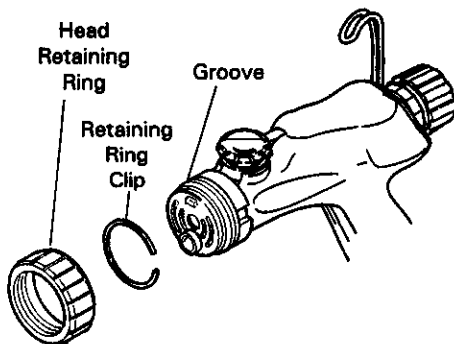

Figure 23



TROUBLESHOOTING AND SERVICE CHECKS

**Normal Spray Pattern:**  
 Proper gun adjustment will result in a normal spray pattern of this shape.



| Condition  | Cause   | Correction   |
|--|---|--|
| A. Heavy top or bottom pattern<br>                | Material build up on air cap, partially plugged horn holes, center hole or jets. Material buildup on orifice of spray head or partially plugged orifice.  | 1. Soak cap or spray head in suitable solvent and wipe clean. To clean orifices use a broom straw or toothpick. Never use a wire or hard instrument. This damages holes and distorts spray pattern.  |
| B. Heavy right or left side pattern<br>           | Note: To determine where material buildup is, invert cap and test spray. If pattern shape stays in the same position, the condition is caused by material buildup in spray head. If pattern changes with cap movement, the condition is in the air cap. |  |
| C. Heavy center pattern<br>                       | Too much material.<br><br>Material too thick.<br><br>Insufficient horn (fan) air.   | Reduce fluid flow by turning fluid control knob clockwise. Reduce fluid pressure or increase atomization pressure.<br><br>Thin.<br><br>Increase horn air if not fully open.                          |
| D. Split spray pattern or reduced fluid flow<br> | Not enough material or too high atomization pressure.<br><br>Excessive horn (fan) air.  | Reduce air pressure or increased fluid flow by turning fluid control knob counterclockwise or increase fluid pressure on pressure feed container.<br><br>Reduce horn air.                            |
| E. Jerky or fluttering spray<br>                | Loose air cap.<br><br>Obstructed fluid passage or tube.<br><br>Loose or cracked fluid tube in cup or tank.<br><br>Insufficient fluid in cup or pressure tank.   | Tighten retaining ring.<br><br>Clean.<br><br>Tighten or replace.<br><br>Fill cup or tank.  |
| F. Improper spray pattern.   | Gun improperly adjusted.<br><br>Dirty air cap or fluid tip (nozzle) exterior.<br><br>Spray head orifice obstructed.<br><br>Baffle seal (11) mis-shaped, out of position, or damaged.  | Readjust gun. Follow instructions carefully.<br><br>Clean air cap or fluid tip.<br><br>Clean.<br><br>Replace or reposition.  |
| G. Unable to get round spray.  | Spray head loose.<br><br>Fan adjustment screw not seating properly.   | Tighten spray head retaining ring.<br><br>Clean or replace.  |
| H. Will not spray.   | No air pressure at gun.<br><br>Fluid pressure too low.<br><br>Fluid control knob not open enough.<br><br>If using pneumatic trigger, large air leak ahead of piston.  | Check air supply and air lines.<br><br>Increase fluid pressure at tank.<br><br>Open by turning counterclockwise. See Warnings on Page 4 of this manual.<br><br>Identify air leak source and correct. |

## TROUBLESHOOTING (continued)

| Condition   | Cause  | Correction   |
|---|--|--|
| I. Fluid leakage from spray head.   | Fluid packing worn.<br>Spray head and needle worn or damaged.<br>Spray head loose.<br>Fluid packing installed backwards.   | Replace<br>Replace.<br>Tighten spray head retaining ring.<br>Install properly. See Figure 8.                                     |
| J. Dripping from spray head orifice.  | Obstruction in orifice.<br>Spray head and needle worn or damaged.<br>Needle return spring missing or damaged.  | Clean.<br>Replace.<br>Replace.   |
| K. Reduced fluid flow.  | Rear knob mis-adjusted.<br><br>Back pressure on fluid column from "MP" nozzle.   | Turn fluid control knob counterclockwise to increase flow. See Warning on Page 4 of this manual.<br><br>Increase fluid pressure. |
| L. Cannot stop air or fluid flow.   | Fluid control knob turned out too far (note air leaks through opening in knob).<br>Excessive air leak in rear of gun behind piston.<br>Orifice in piston U-Cup obstructed.<br>Seal face of bushing and/or piston U-Cup.          | Turn knob in clockwise.<br>Identify cause and correct.<br>Clean orifice in U-Cup.<br>Replace.                                    |
| M. Slow (sluggish) needle return when trigger released (pneumatic trigger). | Partial obstruction in orifice of piston U-Cup.<br>Excessive air leak in rear of gun.<br>Paint accumulation between primary trigger (27) and skeleton (50) not allowing trigger to "relax" when released.                        | Clean Orifice.<br>Identify cause and correct.<br>Clean off overspray.  |
| N. Pneumatic trigger will not function or is sluggish when activated.       | Insufficient air pressure (approximately 6 PSI (.4 bar) air cap pressure required for 65-10 spray head).<br>Pneumatic trigger module dirty, caused by soaking the gun (not recommended).<br>Pneumatic trigger module parts worn. | Increase air pressure.<br><br>Replace pneumatic trigger module (24).<br><br>Replace pneumatic trigger module (24).               |



**WARRANTY - Two Year Limited Warranty**

Your DeVilbiss spray gun is warranted to be free of defects in materials and workmanship for a period of two years from date of original purchase. This warranty does not cover failures resulting from abuse, improper maintenance, misuse, or normal wear. If found to be defective during the warranty period, DeVilbiss will, at its option, either repair or replace the product. THERE IS NO OTHER EXPRESS WARRANTY, IMPLIED WARRANTIES, INCLUDING THOSE OF MERCHANTABILITY AND FITNESS FOR A PARTICULAR PURPOSE, ARE LIMITED TO 24 MONTHS FROM PURCHASE AND TO THE EXTENT PERMITTED BY LAW. ANY AND ALL IMPLIED WARRANTIES ARE EXCLUDED. THIS IS THE EXCLUSIVE REMEDY, AND LIABILITY FOR CONSEQUENTIAL AND INCIDENTAL DAMAGES UNDER ANY AND ALL WARRANTIES IS EXCLUDED TO THE EXTENT EXCLUSION IS PERMITTED BY LAW. SOME STATES DO NOT ALLOW LIMITATIONS ON HOW LONG AN IMPLIED WARRANTY LASTS, OR THE LIMITATION OR EXCLUSION OR CONSEQUENTIAL OR INCIDENTAL DAMAGE, SO THE ABOVE LIMITATIONS OR EXCLUSIONS MAY NOT APPLY TO YOU.

**WARRANTY - EUROPEAN NOTE**

This warranty will not affect the purchaser's statutory rights, for example, under the U.K. Consumer Protection Act.

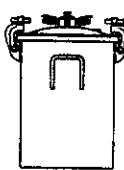
ACCESSORIES

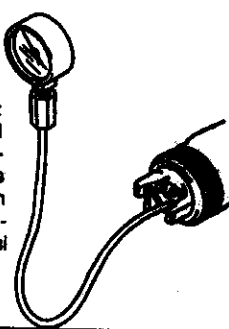
|  |  |   |  |   |
|--|--|---|--|---|
| <p><b>QMGZ SolventSaver™<br/>Hose/Gun Cleaner</b></p>  <p>2 Gal. 8.5 liters) galvanized tank used to clean the inside of hose and material passages of the gun. Available in U.S. only.</p> | <p><b>HD-503 SolventSaver™<br/>Hose/Gun Cleaner</b></p>  <p>2 Qt. (2.1 liters) Hose/Gun Cleaner used to clean the inside of hose, fluid passageways of gun &amp; other paint equipment. Available in U.S. only.</p> | <p><b>Spray Gun Lube<br/>SSL-10 (2 oz. bottle)</b></p>  <p>Compatible with all paint materials: contains no silicone or petroleum distillates to contaminate paint. MSDS available upon request.</p> | <p><b>GC-100-K5 (5 each) or GC-100-K50 (50 each) Disposable Spray Gun Covers</b></p> <p>Save money by reducing cleaning time and maintenance with these covers that also limit operator exposure to overspray.</p> | <p><b>OMX-5033-45MP Or<br/>OMX-5033-63MP<br/>Air Cap Test Kit</b></p>  <p>Measures atomizing pressure at the air cap. Used to confirm pressure in states where legislation prohibits pressures over 10 psi (.7 bar).</p> |
|--|--|---|--|---|

**WORLDWIDE SALES AND SERVICE LISTING - [www.devilbiss.com](http://www.devilbiss.com)**

**DeVILBISS INDUSTRIAL SPRAY EQUIPMENT**

DeVilbiss has authorized distributors throughout the world. **FOR TECHNICAL ASSISTANCE OR DISTRIBUTOR NEAREST YOU, CALL TOLL FREE 1-800-338-4448 (U.S.A. & Canada). FOR LOCAL CALLS, SEE LISTING BELOW.**

|  |                         |
|--|-------------------------|
| <b>U.S./Canada Sales &amp; Customer Service Office</b> | <b>Address</b>          |
| MAUMEE, OH 43537                                       | 1724 Indian Wood Circle |

**Telephone No.**  
(419) 891-8200  
**Toll Free Fax No. 1-800-338-0131**

**DeVILBISS AUTOMOTIVE REFINISHING**

DeVilbiss has authorized distributors throughout the world. For equipment, parts and service, check the Yellow Pages under "Automobile Body Shop Equipment and Supplies." If further assistance is required, write or call one of the following DeVilbiss Distribution Centers or Sales Offices nearest you. **FOR TECHNICAL ASSISTANCE, CALL TOLL FREE 1-800-445-3988 (U.S.A. & Canada). FOR LOCAL CALLS, SEE LISTING BELOW.**

|                                     |                         |
|-------------------------------------|-------------------------|
| <b>U.S. Customer Service Office</b> | <b>Address</b>          |
| Maumee, OH 43537                    | 1724 Indian Wood Circle |

**Telephone No.**  
General Inquiry (419) 891-8100  
**Toll Free Fax No. 1-800-445-6643**

# DEVILBISS

An Illinois Tool Works Company