

FLG-615 AND FLG-635 SPRAY GUN AND GFC-502 CUP

IMPORTANT: Before using this equipment, read all safety precautions on page 2 and instructions. Keep for future use.

DESCRIPTION

The FLG-615 and FLG-635 are light weight, general purpose gravity feed spray guns for both conventional and HVLP spraying applications suitable for use with a wide variety of common coating materials.

WARNING

Halogenated hydrocarbon solvents - for example; 1, 1, 1-trichloroethane and methylene chloride - can chemically react with the aluminum in this gun and cause an explosion hazard. Read the label or data sheet for the material you intend to spray. Do not use spray materials containing these solvents with this spray gun.

IMPORTANT: This gun may be used with most common coating and finishing materials. It is designed for use with mildly corrosive and non-abrasive materials. If used with other high corrosive or abrasive materials, it must be expected that frequent and thorough cleaning will be required and the necessity for replacement of parts will be increased.

OPERATION

Strain material thru 60 or 90 mesh screen.

Model FLG-615:

The No. 1 (conventional) air cap requires an air supply at the gun inlet of approximately 45 psi, measured with the trigger pulled and can be operated from a 3 H.P. compressor.

Model FLG-635:

The No. 3 (HVLP) air cap requires an air supply at the gun inlet of 23 psi max., measured with the trigger pulled and can be operated from a 3 H.P. compressor.

This gun was manufactured to provide maximum transfer efficiency by limiting air cap pressure to 10 psi (complies with rules issued by SCAQMD and other air quality authorities).

This gun will produce approximately 10 psi cap pressure at 23 psi gun inlet pressure, as measured at the gun inlet. An air cap test kit (see Accessories) should be used to insure 10 psi cap pressure is not exceeded.

Adjust inlet air pressure to provide a uniform dispersion of atomized paint throughout the pattern. Keep air pressure as low as possible to minimize bounce - back and overspray. Excessive pressure will result in split spray patterns. Inadequate pressures will cause heavy centered patterns and poor atomization. See Spray Gun Guide, SB-2-001, which is available upon request, for details concerning set up of spray guns.

PREVENTIVE MAINTENANCE

To clean air cap and fluid tip, brush exterior with a stiff bristle brush. If necessary to clean cap holes, use a broom straw or toothpick if possible. If a wire or hard instrument is used, extreme care must be used to prevent scratching or burring of the holes which will cause a distorted spray pattern.

To clean fluid passages, remove excess material at source, then flush with a suitable solvent. Wipe gun exterior with a solvent dampened cloth. Never completely immerse in solvent as this is detrimental to the lubricants and packings.

Note

When replacing the fluid tip or fluid needle, replace both at the same time. Using worn parts can cause fluid leakage. Using the supplied fluid tip tool (16), tighten fluid tip hand tight.

CAUTION

To prevent damage to the fluid tip (3) or fluid needle (6), be sure to either 1) pull the trigger and hold while tightening or loosening the fluid tip or 2) remove fluid needle adjusting screw (15) to relieve spring pressure against needle collar.

Spray Gun Lubrication

Daily, apply a drop of SSL-10 spray gun lube at trigger bearing stud (11) and the stem of the air valve (17) where it enters the air valve assembly (22). The shank of the fluid needle (6) where it enters the packing nut (8) should also be oiled. The fluid needle packing (9) should be kept soft and pliable by periodic lubrication. Make sure the baffle (5) and retaining ring (1) threads are clean and free of foreign matter. Before assembling retaining ring to baffle, clean the threads thoroughly, then add two drops of SSL-10 spray gun lube to threads. The fluid needle spring (14) and air valve spring (18) should be coated with a very light grease, making sure that any excess grease will not clog the air passages. For best results, lubricate the points indicated, daily.

- A. Trigger Points
- B. Packing
- C. Adjusting Valves
- D. Baf

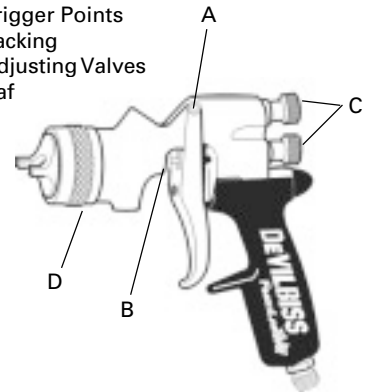

DESCRIPTION - 120175 (GFC-502)

This 32 oz. cup is designed to be used with or without the DeVilbiss disposable cup liner. The cup liner allows painting in any position and simplifies clean up.

This gravity feed cup is designed to work with the FLG, GFG and GFHV gravity feed spray guns. The cup is constructed from durable aluminum to provide trouble-free operation. The cup insert is electroless nickel plated brass. The disposable cup lid is recyclable and is constructed with recycled polyethylene. The lid has a unique drip check to prevent paint from dripping out of the vent in the lid.

ASSEMBLY OF CUP TO GUN (with or without disposable liner)

1. Remove one of the cup gaskets (26) from the poly bag.
2. Place this gasket in the fluid inlet of the gun body. See drawing on page 4.
3. Store remaining cup gaskets in safe place for future use.
4. Place filter (25) in cup outlet at this time if desired. See drawing on page 4.
5. Assemble cup to gun and tighten hand tight.

ASSEMBLY OF DISPOSABLE CUP LINER

Note

This paint cup can be used with or without the cup liner. Skip to page 3, Column 2, Filling With Paint (without disposable cup liner) if not using cup liner.

1. Locate piercing tool.

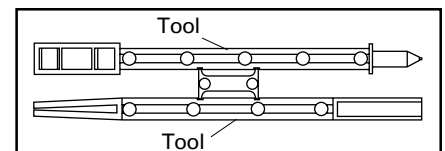

SAFETY PRECAUTIONS

This manual contains information that is important for you to know and understand. This information relates to **USER SAFETY** and **PREVENTING EQUIPMENT PROBLEMS**. To help you recognize this information, we use the following symbols. Please pay particular attention to these sections.

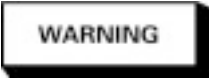

Important safety information - A hazard that may cause serious injury or loss of life.





Important information that tells how to prevent damage to equipment, or how to avoid a situation that may cause minor injury.

Note

Information that you should pay special attention to.

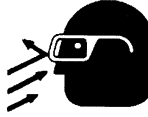

The following hazards may occur during the normal use of this equipment. Please read the following chart before using this equipment.

HAZARD	CAUSE	SAFEGUARDS
<p>Fire</p> 	<p>Solvent and coatings can be highly flammable or combustible especially when sprayed.</p>	<p>Adequate exhaust must be provided to keep air free of accumulations of flammable vapors.</p> <p>Smoking must never be allowed in the spray area.</p> <p>Fire extinguishing equipment must be present in the spray area.</p>
<p>Solvent Spray</p> 	<p>During cleaning and flushing, solvents can be forcefully expelled from fluid and air passages. Some solvents can cause eye injury.</p>	<p>Wear eye protection.</p>
<p>Inhaling Toxic Substances</p> 	<p>Certain materials may be harmful if inhaled, or if there is contact with the skin.</p>	<p>Follow the requirements of the Material Safety Data Sheet supplied by your coating material manufacturer.</p> <p>Adequate exhaust must be provided to keep the air free of accumulations of toxic materials.</p> <p>Use a mask or respirator whenever there is a chance of inhaling sprayed materials. The mask must be compatible with the material being sprayed and its concentration. Equipment must be as prescribed by an industrial hygienist or safety expert, and be NIOSH approved.</p>
<p>Explosion Hazard - Incompatible Materials</p> 	<p>Halogenated hydrocarbon solvents - for example; methylene chloride and 1, 1, 1 - Trichloroethane are not chemically compatible with the aluminum that might be used in many system components. The chemical reaction caused by these solvents reacting with aluminum can become violent and lead to an equipment explosion.</p>	<p>Guns with stainless steel internal passageways may be used with these solvents. However, aluminum is widely used in other spray application equipment - such as material pumps, regulators, valves, and this gun and cup. Check all equipment items before use and make sure they can also be used safely with these solvents. Read the label or data sheet for the material you intend to spray. If in doubt as to whether or not a coating or cleaning material is compatible, contact your material supplier.</p>

2. "Break-off" tool sections from web.

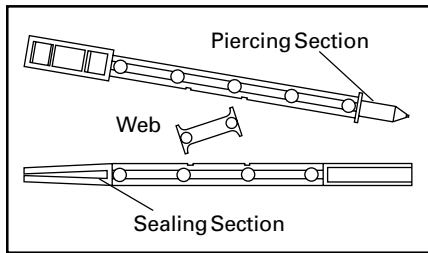

3. Locate tool connection ends.

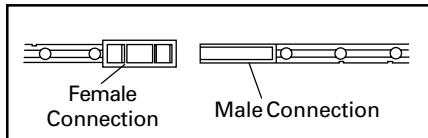

4. Assemble tool connection together.

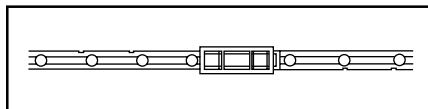

5. Locate drain bushing and piercing end of tool.

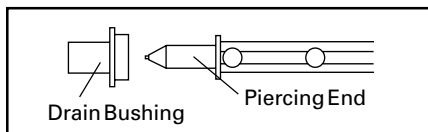

6. Assemble bushing on tool.

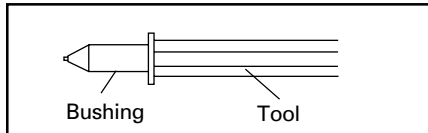

7. Open liner and insert bushing through liner bottom.

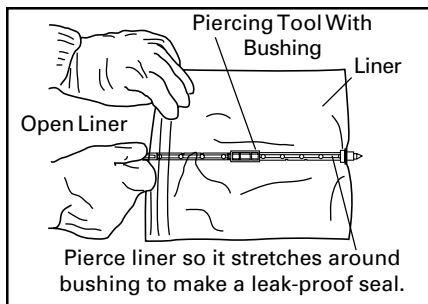

8. Insert liner with bushing into cup hole.

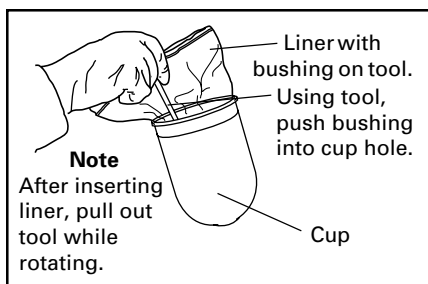

FILLING WITH PAINT (with disposable cup liner)

1. Place gun in gun holder and carefully open liner. Don't pull liner up or bushing may be pulled out of drain hole.
2. While holding funnel/strainer, fill the liner to within 1" (25 mm) of the cup's top. This will allow room to fold the liner into the paint cup.

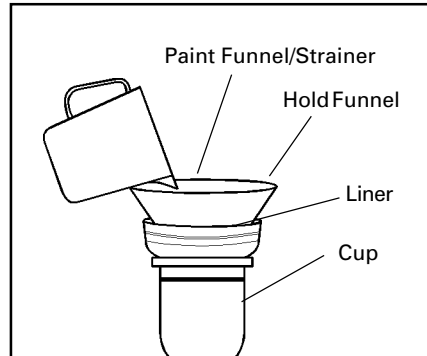

3. Starting at one end, slip the liner sealer end of the piercing tool over the liner's zipper. Hold the liner at the same end and slide the tool along the zipper. Make sure the tool overlaps the zipper.

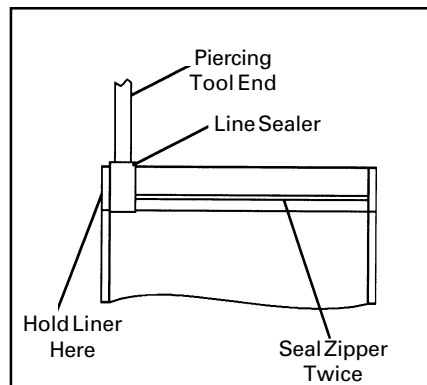

Note

Double check the zipper by sliding your fingers along the zipper. Smooth out any "bumps". "bumps" are an indication the zipper is not sealed at that area.

4. Fold top of liner down into cup before installing lid.

FILLING WITH PAINT (without disposable liner)

Fill the cup with paint to the full mark. **Do not overfill.**

INSTALLING THE LID

Place plastic lid on the top of the cup, and **push in the center of the lid to assemble lid.** Fold vent cap and push onto center portion of lid (if vent cap is not already assembled).

PAINTING

This disposable liner allows you to spray in any position, even upside down. To spray upside down, you must first purge the air from the cup liner.

To purge air from cup liner:

1. Connect to proper air supply (minimum of 20 PSI)
2. Turn cup upside down (See Figure below)
3. Trigger gun until a constant paint flow is observed.

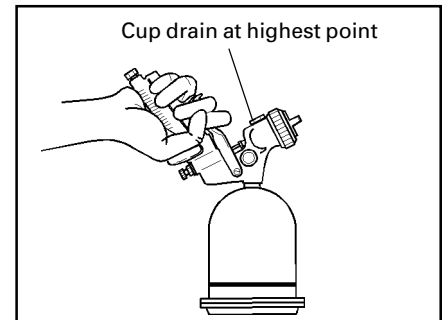

CLEANING (without disposable liner)

Note

For routine cleaning, it is not necessary to remove cup from gun. Do not remove washer (26) from gun. If washer (26) is removed, it must be replaced.



Do not soak the lid in solvent for extended periods of time. Doing so could cause cup/lid sealing problems and leakage.

The cup lid is designed to be disposable but may be cleaned and reused if slightly contaminated with overspray. **If lid becomes tight, or does not fit, it is due to extended soaking in solvent. Let lid air dry overnight and the lid should return to its original size and fit.**

Remove lid and properly dispose of any excess paint. Pour in a small amount of clean solvent. The amount will vary with different coatings and solvents. Reinstall lid. Shake cup to wash down the inside surfaces. **Hold lid while shaking to prevent lid from coming off.** Pull trigger to allow some solvent to be flushed through gun. Remove lid and pour out dirty solvent. Add a small amount of clean solvent and repeat procedure. Wipe exterior of lid with a clean cloth and clean solvent.

If a paint filter was used in the bottom of the cup outlet, it should be removed and cleaned or replaced at this time. Dispose of used cup lid if contaminated and replace with new.

CLEANING (with disposable cup liner)

1. Disconnect the air hose and remove the paint cup lid.

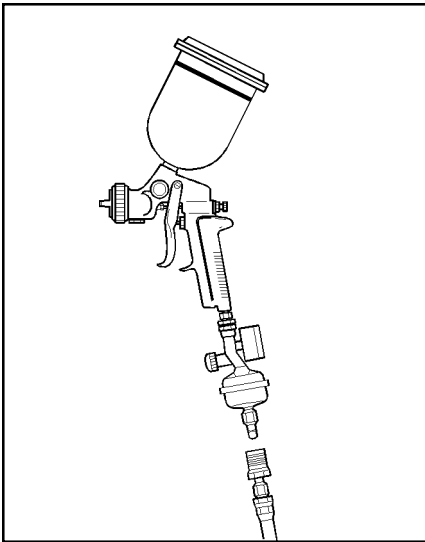

2. While holding disposable cup liner, point gun upwards and pull trigger to allow paint in gun to drain into liner.

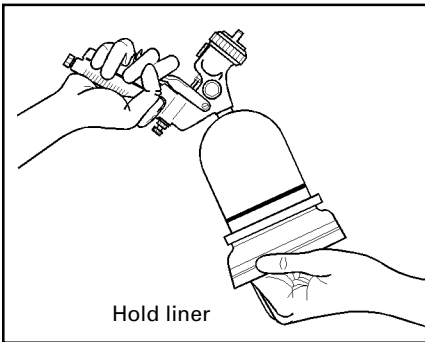

3. While still pointing the gun upwards, carefully pull out liner. Keep drain bushing up to prevent leaking. To prevent paint from being forced out of bushing, don't squeeze the liner while handling it.

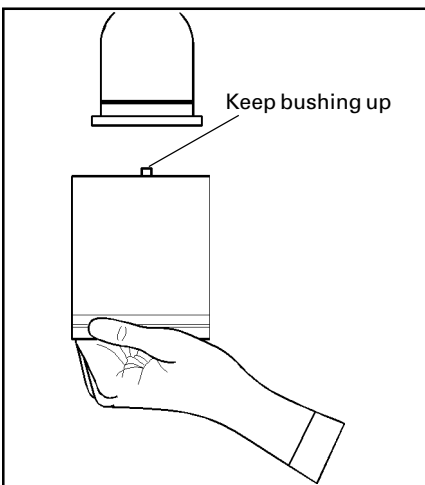

Note

If there is a large amount of paint in paint liner, open zipper and empty paint before removing liner.

4. Properly dispose of remaining paint in paint liner. Open zipper to allow for quicker draining of paint. Dispose of used liner and bushing - **Do Not Reuse**.

Note

If drain bushing remains in cup drain, use needle nose pliers to remove. See Step 6 for proper cleaning.

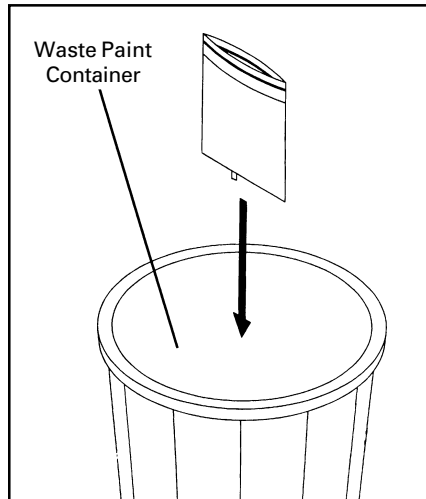

5. Pour a small amount of clean paint solvent into paint cup.

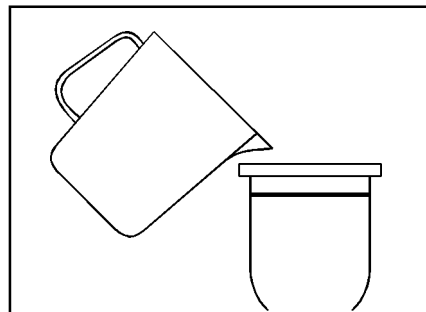

6. Clean drain hole with cleaning brush (not supplied with cup). Drain hole must be kept clean for proper sealing and easy removal of drain bushing.

View Showing Filter/Cup Installation

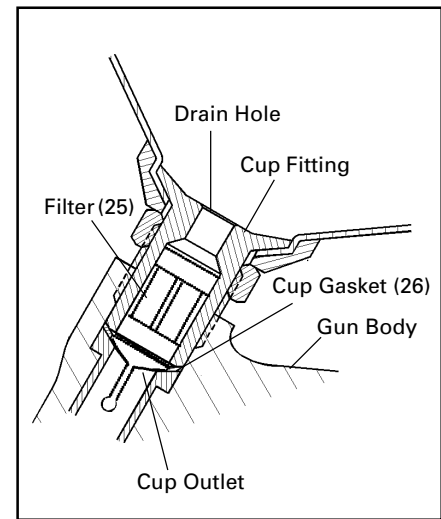

Gun Drawing

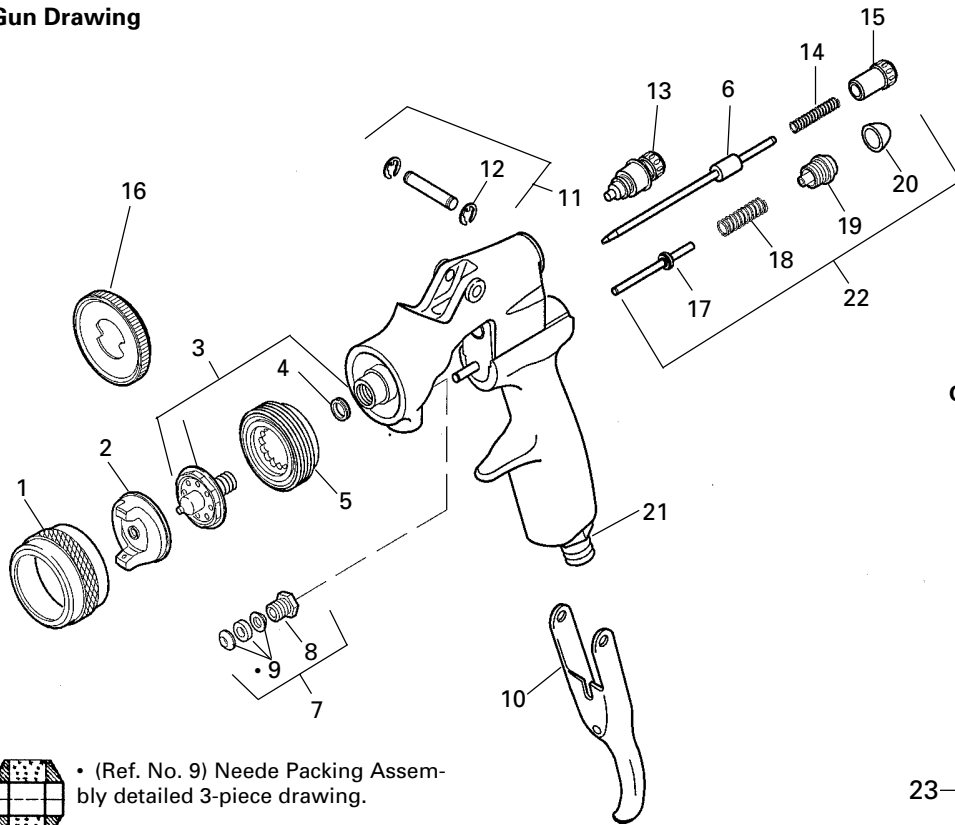

• (Ref. No. 9) Needle Packing Assembly detailed 3-piece drawing.

PARTS LIST

Ref. No.	Computer Part No.	Replacement Part No.	Description	Ind. Parts Required
1	690002	FLG-101-K2	Retaining Ring (Kit of 2)	1
2	---	See Chart 1	Air Cap	1
3	---	See Chart 1	Fluid Tip, Seal and Tip Tool	1
*4	690015	FLG-4-1-K5	Fluid Tip Seal (Kit of 5)	1
5	690007	FLG-105	Baffle	1
6	690011	FLG-431	Fluid Needle	1
*7	690012	FLG-440-K5	Packing Kit (includes 1 Packing Nut and 5 Packing Sets)	1
*8	---	---	Packing Nut	1
9	192109	JGA-4035-K5	Packing Kit (Kit of 5)	1
10	519132	FLG-412	Trigger	1
*11	519029	FLG-8-K2	Trigger Stud Kit (Kit of 2)	1
*12	---	---	Circlip	2
13	690010	FLG-416	Spreader Adjustment Valve	1
*14	---	---	Spring	1
*15	690008	FLG-109-K2	Needle Adjusting Screw (Kit of 2)	1
*16	690009	FLG-111-K2	Fluid Tip Tool (Kit of 2)	1
*17	---	---	Air Valve Stem and Seal	1
*18	---	---	Air Valve Spring	1
*19	---	---	Air Valve Cap Body	1
*20	---	---	Air Valve Cap	1
21	519054	FLG-40	Air Inlet Adapter	1
22	519134	FLG-414	Air Valve Service Kit	1
23	120175	GFC-502	Metal Gravity Feed Cup	1
24	190944	GFC-404-K2	Disposable Lid Kit (Kit of 2)	1
25	190181	KGP-5-K5	Filter Kit (Kit of 5)	1
26	192151	KGP-13-K5	Cup Gasket (Blue) (Kit of 5)	1
27	190966	OMX-70-K48	Disposable Liner Kit (Kit of 48) Kits include: 1 Piercing Tool Necessary Liners & Drain Bushings	1

GFC-502 Cup

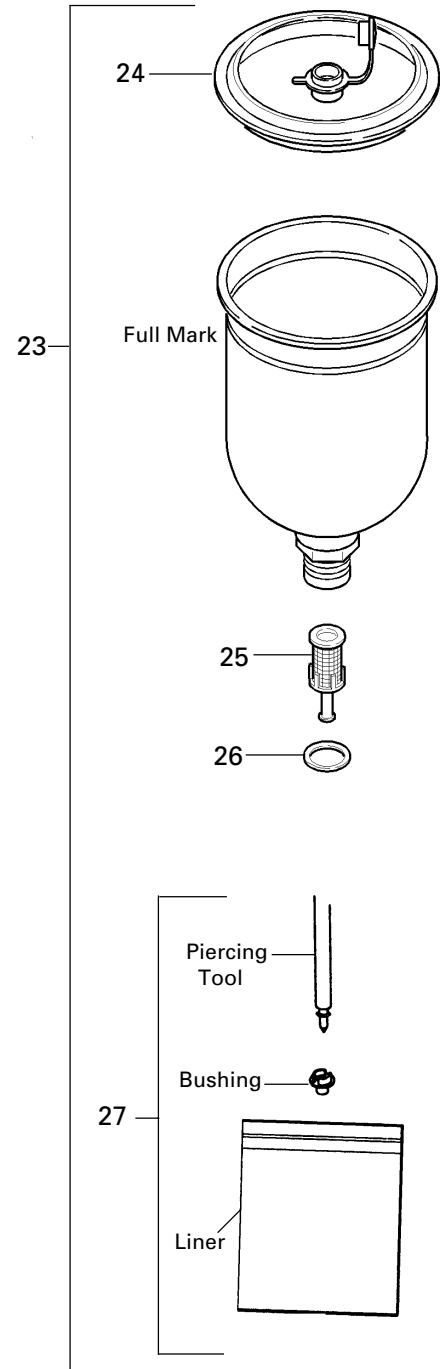





* A quantity of necessary parts is included in Repair Kit FLG-480 (Computer No. 690013) for complete gun repair and should be kept on hand for service convenience.

Chart 1 For Model Numbers FLG-615 and FLG-635 Gravity Feed Spray Guns

Spray Gun Model Number	Spray Gun Computer Number	No. on Air Cap	Ref. No. 2 Air Cap		Ref. No. 3 Fluid Tip		Fluid Tip Size
			Part No.	Computer No.	Part No.	Computer No.	
FLG-615-114	611101	1	FLG-1-1	690000	FLG-102-14K	690003	1.4 (Std.)
FLG-635-316	611103	3	FLG-1-3	690001	FLG-102-16K	690004	1.6 (Std.)
					FLG-102-14K	690003	1.4 (Std.)
					FLG-102-18K	690005	1.8 (Opt.)
					FLG-102-22K	690006	2.2 (Opt.)

TROUBLESHOOTING

CONDITION	CAUSE	CORRECTION
Heavy top or bottom pattern 	Horn holes plugged. Obstruction on top or bottom of fluid tip. Cap and/or tip seat dirty.	Clean. Ream with non-metallic point. Clean. Clean.
Heavy right or left side pattern 	Left or right side horn holes plugged. Dirt on left or right side of fluid tip. Remedies for the top-heavy, bottom-heavy, right-heavy, and left-heavy patterns: 1. Determine if the obstruction is on the air cap or the fluid tip. Do this by making a test spray pattern. Then, rotate the cap one-half turn and spray another pattern. If the defect is inverted, obstruction is on the air cap. Clean the air cap as previously instructed. 2. If the defect is not inverted, it is on the fluid tip. Check for a fine burr on the edge of the fluid tip. Remove with #600 wet or dry sand paper. 3. Check for dried paint just inside the opening; remove by washing with solvent.	Clean. Ream with non-metallic point. Clean.
Heavy center pattern 	Fluid flow too high for atomization air. Material flow exceeds air cap's capacity. Spreader adjustment valve set too low. Atomizing pressure too low. Material too thick.	Balance air pressure and fluid flow. Increase spray pattern width with spreader adjustment valve. Thin or lower fluid flow. Adjust. Increase pressure. Thin to proper consistency.
Split spray pattern 	Atomization air pressure too high. Fluid flow too low. Spreader adjusting valve set too high.	Reduce at transformer or gun. Increase fluid flow (increases gun handling speed). Adjust.
Jerky or fluttering spray 	*Loose or damaged fluid tip/seat. Material level too low. Container tipped too far. Obstruction in fluid passage. Dry or loose fluid needle packing nut.	Tighten or replace. Refill. Hold more upright. Backflush with solvent. Lubricate or tighten.
Unable to get round spray	Spreader adjustment screw not seating properly. Air cap retaining ring loose.	Clean or replace. Tighten.
Will not spray	No air pressure at gun. Fluid needle adjusting screw not open enough. Fluid too heavy for gravity feed.	Check air supply and air lines, blow out gun air passages. Open fluid needle adjusting screw. Thin material and/or change to larger tip size.
Paint bubbles in cup	Fluid tip not tight.	Tighten tip.
Fluid leaking or dripping from cup lid	Cup lid loose. Dirty threads on cup or lid. Cracked cup or lid.	Tighten lid. Clean. Replace cup and lid.
Starved spray pattern	Inadequate material flow. Low atomization air pressure.	Back fluid adjusting screw out to first thread, or change to larger tip size. Increase air pressure and rebalance gun.
Excessive overspray	Too much atomization air pressure. Gun too far from work surface. Improper stroking (arcing, gun motion too fast).	Reduce pressure. Adjust to proper distance. Move at moderate pace, parallel to work surface.
Excessive fog	Too much or too fast-drying thinner. Too much atomization air pressure.	Remix properly. Reduce pressure.

*Most common problem.

TROUBLESHOOTING (Continued)

CONDITION	CAUSE	CORRECTION
Dry spray	Air pressure too high. Gun tip too far from work surface. Gun motion too fast. Gun out of adjustment.	Reduce air pressure. Adjust to proper distance. Slow down. Adjust.
Fluid leaking from packing nut	Packing nut loose. Packing worn or dry.	Tighten, do not bind needle. Replace or lubricate.
Fluid leaking or dripping from front of gun	Packing nut too tight. Dry packing. Fluid tip or needle worn or damaged. Foreign matter in tip. Fluid needle spring broken. Wrong size needle or tip.	Adjust. Lubricate. Replace tip and needle. Clean. Replace. Replace.
Fluid dripping or leaking from bottom of cup	Cup loose on gun. Cup gasket worn or missing below cup. Cup threads dirty.	Tighten. Replace cup gasket. Clean.
Runs and sags	Too much material flow. Material too thin. Gun tilted on an angle, or gun motion too slow.	Adjust gun or reduce fluid flow. Mix properly or apply light coats. Hold gun at right angle to work and adapt to proper gun technique.
Thin, sandy coarse finish drying before it flows out	Gun too far from surface. Too much air pressure. Improper thinner being used.	Check distance. Normally approximately 8". Reduce air pressure and check spray pattern. Follow paint manufacturer's mixing instructions.
Thick, dimpled finish "orange peel"	Gun too close to surface. Air pressure too low. Improper thinner being used. Material not properly mixed. Surface rough, oily, dirty.	Check distance. Normally approximately 8". Too much material coarsely atomized. Increase air pressure or reduce fluid flow. Follow paint manufacturer's mixing instructions. Follow paint manufacturer's mixing instructions. Properly clean and prepare.

ACCESSORIES

GFC-503 (Delrin) 20 Oz. Cup
GFC-502 (Aluminum) 32 Oz. Cup
Gravity Feed Cups



These gravity feed cups are designed to be used with FLG, GFG, GFHV or GTI gravity feed spray guns.

KK-700-K10
(10 ea.) 3/8" & 5/8"
Cleaning Brushes

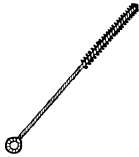

These brushes are helpful in cleaning threads and recesses of gun body.

HARG-510 Air Regulator

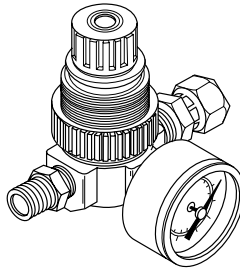

Use to maintain nearly constant outlet pressure despite changes in inlet pressure and downstream flow.

HAV-500 OR HAV-501
Adjusting Valve
(HAV-501 SHOWN)

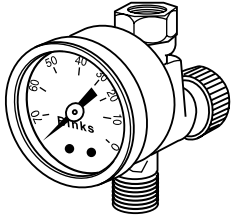

HAV-500 does not have pressure gauge. Use to control air usage at gun.

FLG-463
Air Cap Test Kit
(#3 air cap)

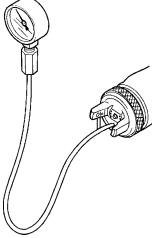

The purpose of this test kit is to measure air cap atomizing air pressure at the center air port of the air cap. Used to confirm code compliance and as a daily quality control measure.

Spray Gun
Lube
SSL-10
(2 oz. bottle)



Compatible with all paint materials; contains no silicone or petroleum distillates to contaminate paint.

MSP-524
Twin Cartridge,
Paint Spray
Respirator



NIOSH-Certified (TC84A-1623) for respiratory protection in atmospheres not immediately dangerous to life.

GH-505 Gun Holder

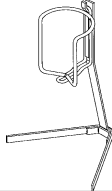

Gun holders are made to hold standard paint cups, gravity feed guns and cups, and paint filters.

Automotive Quick Connects
For HVLP Guns (Air)
High Flow Type.

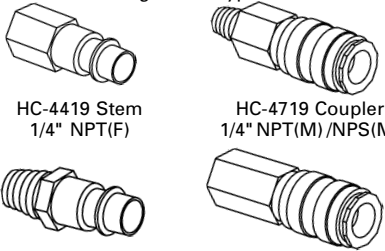

HC-4419 Stem 1/4" NPT(F)
 HC-4719 Coupler 1/4" NPT(M)/NPS(M)
 HC-1166 Stem 1/4" NPT(M)
 HC-4720 Coupler 1/4" NPT(F)

OMX-70-K48 PAINT CUP
LINER KIT

Allows quick and easy clean-up.
Consists of: 1 - Piercing Tool, 48 - Disposable Liners, 48 - Drain Bushings

HAF-507 Whirlwind™
In-Line Air Filter

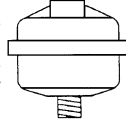

Removes water, oil, and debris from the air line.

WR-103 Wrench

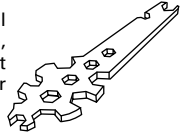

Contains all necessary tip, hose and nut sizes used on or with gun.

Industrial Quick Connects For HVLP Guns (Air)



HC-4419 Stem 1/4" NPT(F)
 HC-4699 Coupler 1/4" NPT(M) /NPS(M)
 HC-1166 Stem 1/4" NPT(M)
 HC-4700 Coupler 1/4" NPT(F)

WARRANTY
 This product is covered by DeVilbiss' 1 Year Limited Warranty. See SB-1-000 which is available upon request.

DeVILBISS WORLDWIDE SALES AND SERVICE LISTING - www.devilbiss.com

INDUSTRIAL FINISHING

DeVilbiss has authorized distributors throughout the world. **FOR TECHNICAL ASSISTANCE OR THE DISTRIBUTOR NEAREST YOU, CALL TOLL FREE 1-888-992-4657 (U.S.A. AND CANADA ONLY). FOR LOCAL CALLS, SEE LISTING BELOW.**

U.S./Canada Sales & Customer Service Office
 GLENDALE HEIGHTS, IL 60139

Address
 195 Internationale Blvd.

Telephone No.
 (630) 237-5000
 Toll Free Fax No. 1-877-790-6965

AUTOMOTIVE REFINISHING

DeVilbiss has authorized distributors throughout the world. For equipment, parts and service, check the Yellow Pages under "Automobile Body Shop Equipment and Supplies". **FOR TECHNICAL ASSISTANCE, CALL TOLL FREE 1-800-445-3988 (U.S.A. ONLY). FOR LOCAL CALLS, SEE LISTING BELOW.**

U.S. Customer Service Office
 MAUMEE, OH 43537

Address
 1724 Indian Wood Circle

Telephone No.
 (419) 891-8100
 Toll Free Fax No. 1-800-445-6643

