

Model 95G Gravity Feed Spray Gun



INTRODUCTION

This unique spray gun is engineered with sprayer comfort, operating simplicity, and paint usage efficiency in mind. Ideal for automotive refinishing, test labs, touch-up spraying, and small batch production spraying.

Light-weight, well balanced, and ergonomically contoured gun handle eliminates operator fatigue.

Gravity feed spray method allows for fast paint fill and maximum paint usage from the cup, eliminating paint waste during the gun clean-up. It also eliminates cumbersome pressure feed equipment. Requires only one air hose for operation. For waterborne, solvent based materials, ceramics, gel-coats, and wet out jobs.

FEATURES:

- Proven technology of 60 Series air and fluid nozzles.
- Stainless steel fluid needle and nozzle.
- Light-weight gun body. (1 lb., 11 oz. with cup)
- Wide gun trigger for operator comfort during spraying.
- Precise fan pattern size adjustment.
- Offered with standard 1 liter aluminum anodized cup.

In this part sheet, the words **WARNING**, **CAUTION** and **NOTE** are used to emphasize important safety information as follows:

⚠ WARNING
 Hazards or unsafe practices which could result in severe personal injury, death or substantial property damage.

⚠ CAUTION
 Hazards or unsafe practices which could result in minor personal injury, product or property damage.

NOTE
 Important installation, operation or maintenance information.

⚠ WARNING

Read the following warnings before using this equipment.



READ THE MANUAL
 Before operating finishing equipment, read and understand all safety, operation and maintenance information provided in the operation manual.



WEAR SAFETY GLASSES
 Failure to wear safety glasses with side shields could result in serious eye injury or blindness.



DE-ENERGIZE, DEPRESSURIZE, DISCONNECT AND LOCK OUT ALL POWER SOURCES DURING MAINTENANCE
 Failure to De-energize, disconnect and lock out all power supplies before performing equipment maintenance could cause serious injury or death.



OPERATOR TRAINING
 All personnel must be trained before operating finishing equipment.



EQUIPMENT MISUSE HAZARD
 Equipment misuse can cause the equipment to rupture, malfunction, or start unexpectedly and result in serious injury.

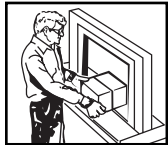

KEEP EQUIPMENT GUARDS IN PLACE
 Do not operate the equipment if the safety devices have been removed.

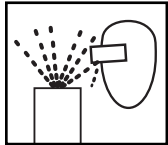

PROJECTILE HAZARD
 You may be injured by venting liquids or gases that are released under pressure, or flying debris.



PINCH POINT HAZARD
 Moving parts can crush and cut. Pinch points are basically any areas where there are moving parts.



AUTOMATIC EQUIPMENT
 Automatic equipment may start suddenly without warning.



INSPECT THE EQUIPMENT DAILY
 Inspect the equipment for worn or broken parts on a daily basis. Do not operate the equipment if you are uncertain about its condition.



NEVER MODIFY THE EQUIPMENT
 Do not modify the equipment unless the manufacturer provides written approval.



KNOW WHERE AND HOW TO SHUT OFF THE EQUIPMENT IN CASE OF AN EMERGENCY



PRESSURE RELIEF PROCEDURE
 Always follow the pressure relief procedure in the equipment instruction manual.



NOISE HAZARD
 You may be injured by loud noise. Hearing protection may be required when using this equipment.



STATIC CHARGE
 Fluid may develop a static charge that must be dissipated through proper grounding of the equipment, objects to be sprayed and all other electrically conductive objects in the dispensing area. Improper grounding or sparks can cause a hazardous condition and result in fire, explosion or electric shock and other serious injury.



FIRE AND EXPLOSION HAZARD
 Never use 1,1,1-trichloroethane, methylene chloride, other halogenated hydrocarbon solvents or fluids containing such solvents in equipment with aluminum wetted parts. Such use could result in a serious chemical reaction, with the possibility of explosion. Consult your fluid suppliers to ensure that the fluids being used are compatible with aluminum parts.



TOXIC FLUID & FUMES
 Hazardous fluid or toxic fumes can cause serious injury or death if splashed in the eyes or on the skin, inhaled, injected or swallowed. LEARN and KNOW the specific hazards of the fluids you are using.



WEAR RESPIRATOR
 Toxic fumes can cause serious injury or death if inhaled. Wear a respirator as recommended by the fluid and solvent manufacturer's Material Safety Data Sheet.

FOR FURTHER SAFETY INFORMATION REGARDING BINKS AND DEVILBISS EQUIPMENT, SEE THE GENERAL EQUIPMENT SAFETY BOOKLET (77-5300).

OPERATION AND MAINTENANCE INSTRUCTIONS

Your new Model 95G Gravity Feed Spray Gun is exceptionally rugged in construction and is built to stand up under hard, continuous use. However, like any other fine precision instrument, its most efficient operation depends on a knowledge of its construction, operation, and maintenance. Properly handled and cared for, it will produce beautiful, uniform finishing results long after other spray guns have worn out.

⚠ WARNING

Servicing the gun while pressurized could result in components or material exiting the gun at high velocity, possibly resulting in personal injury or damage to the spray gun. Before removing any components from the spray gun, shut off air pressure and drain material from the paint cup.

SET-UP FOR SPRAYING (Figure 1) CONNECTING GUN TO AIR HOSE

Air should be supplied by a suitable length of 5/16" diameter air hose fitted with a 1/4 NPS(f) connection at base of gun handle. For hose lengths over 50', use 3/8" hose.

CONNECTING GRAVITY FEED CUP TO GUN

Screw the cup into the spray gun fluid inlet. Fill the cup with filtered paint.

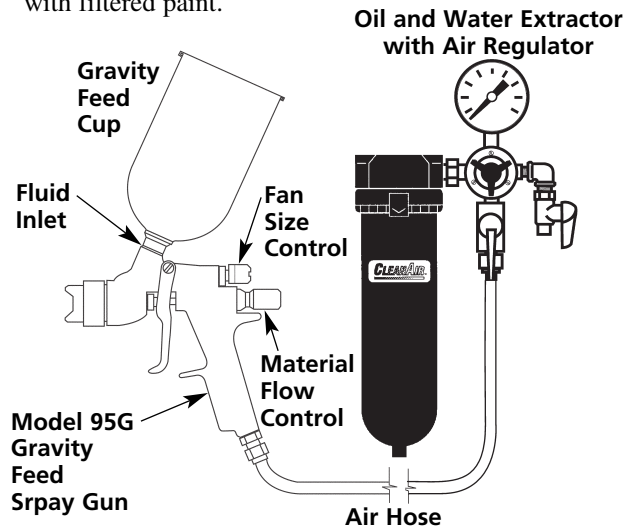

Figure 1

OPERATING THE MODEL 95G GRAVITY FEED SPRAY GUN

NOTE: All numbers in parentheses () refer to item numbers in assembly drawing on Page 6.

CONTROLLING THE MATERIAL FLOW

Correct fluid nozzle size should be selected for proper material flow rate. The material valve control knob (21) may be used to restrict the material needle valve opening and reduce the material flow as necessary.

CONTROLLING THE FAN SPRAY

The fan spray is controlled by means of the side port control assembly (9). Turning this control clockwise until it is closed will give a round spray. Turning it counterclockwise will widen the spray into a fan shape. The fan spray can be turned anywhere through 360° by positioning the air cap (2) relative to the gun. To affect this, loosen retainer ring, position nozzle, then tighten retainer ring.

TROUBLE SHOOTING

FAULTY SPRAY

A faulty spray is often caused by improper cleaning resulting in dried materials around the material nozzle tip or in the air nozzle. Soak these parts in thinners to soften the dried material and remove with a brush or cloth. If either the air cap (2) or fluid nozzle (3) are damaged, these parts must be replaced before perfect spray can be obtained.

⚠ CAUTION

Never use metal instruments to clean the air or material nozzles. These parts are carefully machined and any damage to them will cause faulty spray.

INTERMITTENT SPRAY

Fluttering spray is caused by one of the following:

1. Insufficient material in cup. Refill the cup.
2. Loose fluid nozzle. Tighten snugly.
3. Cup connection loose or dirt in connection. Correct as necessary.
4. Air vent in gravity cup blocked. Clear obstruction.

SPRAY GUN CLEANING INSTRUCTIONS

In certain states, spraying solvents which contain Volatile Organic Compounds (VOC) into the atmosphere when cleaning a spray gun is now prohibited.

In order to comply with these new air quality laws, Binks recommends one of the following two methods to clean your spray finishing equipment.

1. Spray solvent through the gun into a *closed system*. An enclosed unit or spray gun cleaning station condenses solvent vapors back into liquid form which prevents escape of VOCs into the atmosphere.
2. Place spray gun in a washer type cleaner. This system must totally enclose the spray gun, cups, nozzles and

other parts during washing, rinsing and draining cycles. This type of unit must be able to flush solvent through the gun without releasing any VOC vapors into the atmosphere.

CLEANING GUN AND GRAVITY FEED CUP

Remove the cup cover and drain unused material from cup. Carefully rinse cup with solvent. Place clean solvent into the cup and spray this through the gun until it is clean. Remove and clean the cup if necessary. Blow air through the gun to dry it. (Refer to Service Bulletin SBBI-4-043 for cleaning instructions when using cup liners.)

GENERAL SPRAY INSTRUCTIONS

To reduce overspray and obtain maximum efficiency, always spray with the lowest possible fluid/air pressure that produces an acceptable spray pattern.

Excessive atomizing air pressure can increase overspray, reduce transfer efficiency and with some materials, result in poor finish quality from dry spray.

Generally use 30 to 35 psi air at gun inlet (see below). Unusually heavy, difficult to atomize materials may require up to 50 psi at gun inlet.

SPRAY TECHNIQUE

The first requirement for a good resultant finish is the proper handling of the gun. The gun should be held perpendicular to the surface being covered and moved parallel with it. The stroke should be started before the trigger is pulled and the trigger should be released before the stroke is ended. This gives accurate control of the gun and material.

The distance between gun and surface should be 6 to 10 inches depending on material and atomizing pressure. The material deposited should always be even and wet. Lap each stroke over the preceding stroke to obtain a uniform finish.

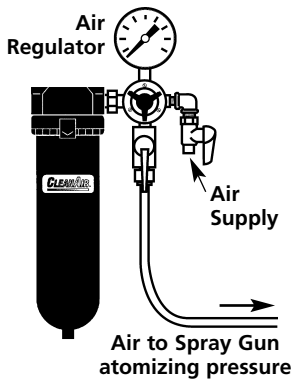
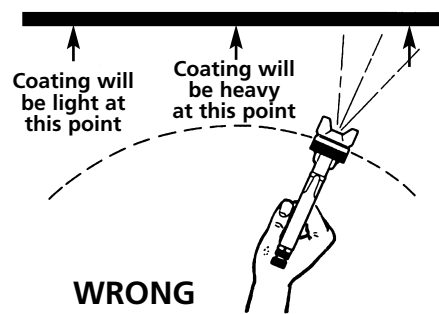
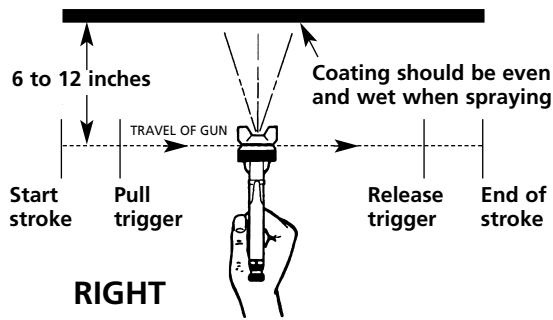

OIL AND WATER EXTRACTOR

OIL AND WATER EXTRACTOR IS IMPORTANT

Achieving a fine spray finish without the use of a good oil and water extractor is virtually impossible.

A regulator/extractor serves a double purpose. It eliminates blistering and spotting by keeping air free of oil and water and it gives precise air pressure control at the gun.

Atomizing pressure must be set to allow for the drop in air pressure between the regulator and the spray gun.

HOSE SIZE RECOMMENDATIONS WITH 60 PSI APPLIED AT AIR SUPPLY

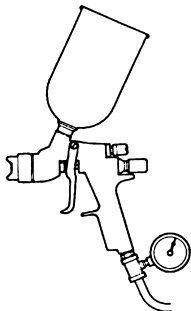

Only 34 psi at gun inlet

25 feet of 1/4" I.D. hose causes a drop of 26 psi between the air supply and the gun.

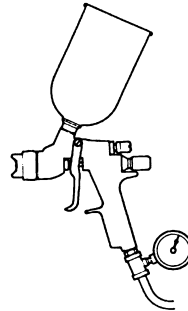

48 psi at gun inlet

25 feet of 5/16" I.D. causes a drop of 12 psi between the air supply and the gun. For this reason we recommend the use of 5/16" hose.

Not Recommended



1/4"

Cross section view showing comparison of inside diameter of air hose (actual size). 60 lbs. regulated pressure.



5/16"

Recommended

STANDARD SET-UP 66SS X 66SD• – ALL OTHERS ARE OPTIONAL

**NOZZLE AND NEEDLE SELECTION CHART
FOR MODEL 95G GRAVITY FEED SPRAY GUNS**

Type of Fluids	Fluid▲ Nozzle	Air Nozzle	Fluid Needle	Max. Pattern at 8" Distance	CFM			Fluid Flow*		
					20	30	40	20	30	40
Low to Medium Viscosity Fluids (14-20 second-No. 2 Zahn) Dyes, Stains, Lacquers, Primers, Waterborne Coats, Base Coat Metallics	65SS	66SD	865	11" @ 40 PSI	7.5	10.5	13.0	168	209	226
	•66SS	66SD	865	15" @ 40 PSI	7.5	10.0	12.0	244	290	350
	66SS	66SK	865	15.5" @ 40 PSI	9.0	11.0	13.5	235	293	367
	L6SS	66SD	865	15" @ 40 PSI	7.5	10.5	13.0	VARIES WITH VISCOSITIES		
	L6SS	66SK	865	15.5" @ 40 PSI	9.0	11.0	13.5			
Medium to High Viscosity Fluids (19-30 second-No. 2 Zahn/ Over 28 sec.-No. 4 Ford) Urethanes, Fillers, Epoxies, Varnishes, Lubricants, Shellacs, Fillers Waterborne, Top Coats	65SS	66SD	865	11.5" @ 40 PSI	7.5	10.5	13.0	176	223	263
	•66SS	66SD	865	12" @ 40 PSI	7.5	10.0	12.0	205	244	275
	66SS	66SK	865	15" @ 40 PSI	9.0	11.0	13.5	230	302	369
	67SS	67SK	867	18" @ 40 PSI	9.0	11.5	14.0	348	453	504
	L6SS	66SD	865	12" @ 40 PSI	7.5	10.5	13.0	VARIES WITH VISCOSITY		
	L6SS	66SK	865	15" @ 40 PSI	9.0	11.0	13.5			
Vitreous Enamels (20-30 second-No. 2 Zahn) Ceramics, Glazes	67VT■ 68VT■	67SK 68SA	867VT■ 868VT■	VARIES WITH FLUID VISCOSITIES						

▲ Fluid Nozzle Reference Chart

Nozzle No.	65SS	66SS	67SS	68SS
Orifice Size	.059	.070	.086	.110

■ Tungsten Carbide Fluid Nozzle & Fluid Needle Tip

*Fluid flow in cc/minute. Divide above fluid flow by 29.6 to convert to fluid ounces (U.S.)

L-Series Fluid Nozzles tend to minimize "smoking effect" at the air cap allowing for less fluid build-up at the air nozzle horns. Typically, they require slightly higher air pressures to achieve the same fluid delivery as standard No. 60 Series nozzles.

NOTE

Pressure feed type air nozzles are not recommended to be used with Model 95G Gravity Feed Spray Gun.

PARTS LIST

(When ordering, please specify Part No.)

ITEM NO.	PART NO.	DESCRIPTION	QTY.	ITEM NO.	PART NO.	DESCRIPTION	QTY.
1	*	AIR CAP ASSEMBLY	1	20	192219	PLASTIC COATED GUN HOOK	1
2	*	FLUID NOZZLE.....	1	21	54-3606	MATERIAL VALVE CONTROL KNOB	1
3	54-918▲	SEALING RING.....	1	22	54-768	AIR CONNECTION.....	1
4	54-4233	HEAD INSERT	1	23	54-4439†	AIR CONNECTION 1/4 BSP (Not Shown)	1
5	54-4369▲	HEAD INSERT SEAL RING	1	24	54-4360	TRIGGER.....	1
6	54-4227	95G GRAVITY FEED HANDLE ASSEMBLY	1	25	54-4370▲	SEAL CARTRIDGE ASSEMBLY.....	1
7	54-4359	TRIGGER STUD	1	26	54-3513	VALVE SPINDLE CAP.....	1
8	82-126	TRIGGER SCREW	1	27	54-4720	1 LITER GRAVITY FEED CUP ASSEMBLY	1
9	54-4364●	SIDE PORT CONTROL ASSEMBLY (Standard).....	1	28	GFC-404■	DISPOSABLE LID ASSEMBLY (Quantity 2 supplied / 54-4720)	1
10	54-3511▲	RETAINING RING.....	×	29	GFC-403	GRAVITY FEED CUP SUB-ASSEMBLY (Aluminum)	×
11	20-6160▲	O-RING	×	30	82-221	CLEANING BRUSH (Flat)	1
12	20-4615▲	O-RING	2	31	54-4213★	WRENCH (Optional)	1
13	54-3515	HOUSING.....	2	32	82-469	GUN BRUSH (Round).....	1
14	54-3520▲	SPRING (Yellow).....	1	33	KGP-13▶	CUP GASKET (Blue).....	1
15	54-3512▲	SPINDLE ASSEMBLY.....	1	34	KGP-5♦	FILTER.....	1
16	54-3518▲	SPRING (Blue).....	2	35	OMX-70✓	DISPOSABLE LINER (Not Shown) (Refer to Service Bulletin SBBI-4-043)	
17	54-3541	HOUSING.....	1				
18	*	FLUID NEEDLE.....	1				
19	54-3871	GUNNERS MATE OIL	1				

- * See Air and Fluid Nozzle Chart on Page 5.
- ▲ Part of Repair Kit 54-3589 Spare Parts Kit.
- Available as optional Quick Change Side Port Control 54-4365.
- × Available as part of its assembly.

- † European gun assemblies only.
- Available in 54-4715 Disposable Lid Kit (quantity of 2) only.
- ★ Not furnished. Please order separately.
- ▶ Available in 54-4717 Cup Gasket (Blue) Kit (quantity of 5) only.
- ♦ Available in 54-4716 Filter Kit (quantity of 5) only.
- ✓ Available in OMX-70-K48 Disposable Liner Kit (quantity of 48) only.

MAINTENANCE

TO REPLACE AIR VALVE AND SPINDLE ASSEMBLY

Remove air valve control knob (21), spring (16), and fluid needle (18). Unscrew housing (17) and remove spindle assembly (15) with springs (14 & 16), seal retainers (13), and o-rings (12). Lubricate new o-rings with Gunners Mate. Assemble components using material needle. Place this assembly along with Housing (17) into gun body and screw into position. Remove material needle and tighten housing.

TO REPLACE FLUID CARTRIDGE ASSEMBLY

Remove material valve control knob (21), spring (16), and remove fluid needle (18). Pull back trigger (24) and remove seal cartridge assembly (25). Remove and discard plastic packing pin in new seal cartridge assembly. Pull back trigger and insert new seal cartridge assembly. Reassemble fluid needle (18), spring (16), and material valve control knob (21).

ACCESSORIES

- 192219 Plastic Coated Gun Hook
(Supplied with gun)
- 54-4352 Gun Bracket (Optional)
- 54-4350 Gun Stand Assembly (Optional)
- 54-4365 Quick Change Side Port Control
(Optional)

- 81-82 Strainer – 145 Mesh – Typical for lacquers
(Optional)
- 81-83 Strainer – 100 Mesh – Typical for metal flake
(Optional)
- 81-84 Strainer – 80 Mesh – Typical for primers
(Optional)

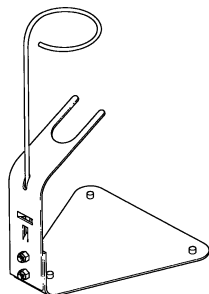

54-4350
Gun Stand
(Optional)

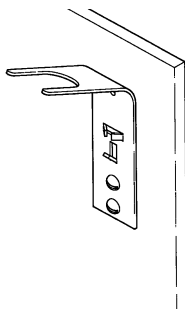

54-4352
Gun Bracket
(Optional)

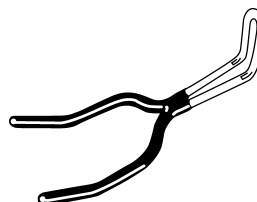

192219
Plastic Coated Gun Hook
(Supplied with outfit)

WARRANTY

This product is covered by Binks' 1 Year Limited Warranty.

Binks Worldwide Sales and Service Listing: www.binks.com

ITW Industrial Finishing

Binks has authorized distributors throughout the world. For technical assistance or the distributor nearest you, see listing below.

U.S./Canada Technical Service Office:

195 Internationale Blvd., Glendale Heights, IL 60139
Toll-Free Telephone: 1-888-992-4657 (U.S.A. and Canada only)
Toll-Free Fax: 1-888-246-5732

77-2652R-7 Revisions: (P2) Replaced warnings page.



An Illinois Tool Works Company