



Binks Model 95AR and 95ARV AUTOMATIC CONVENTIONAL AIR SPRAY GUN (95ARV for Ceramic Coatings)



STANDARD SET-UPS AVAILABLE (See page 7).
OPTIONAL SET-UPS PLEASE ORDER SEPARATELY
(See pages 6 and 7).

AIR SPRAY GUN WITH STAINLESS STEEL FLUID INLET

MODEL 95AR AND 95ARV AUTOMATIC AIR SPRAY GUNS

Ideal for coating test laboratories and where repeated fluid flow adjustments are required. The 95AR Automatic Spray Gun is a conventional style air spray gun. It incorporates all stainless steel fluid inlet, fluid nozzle, and fluid needle; 95ARV incorporates stainless steel fluid inlet, fluid nozzle with T.C. insert and fluid needle with T.C. tip for spraying a wide variety of conventional and waterborne coatings. It is also pneumatically activated for application with reciprocating, rotary, spindle machines, and in stationary gun set-ups. Exceptionally rugged in construction, the

Binks Models 95AR and 95ARV automatic guns are built to stand up under hard, continuous use. However, like any other fine precision instruments, their most efficient operation depends on a knowledge of their construction, operation, and maintenance.

Properly handled and cared for, these guns will produce beautiful, uniform finishing results long after other spray guns have worn out.

CAUTION

Before removing any components from spray gun, shut off air and material pressure.

Replaces
Part Sheet
2655R-1

Part
Sheet
77-2655R-2

Binks Models 95AR and 95ARV AUTOMATIC CONVENTIONAL SPRAY GUNS Typical Arrangement Diagram and Hook-up for Combined Fan and Atomizing Air

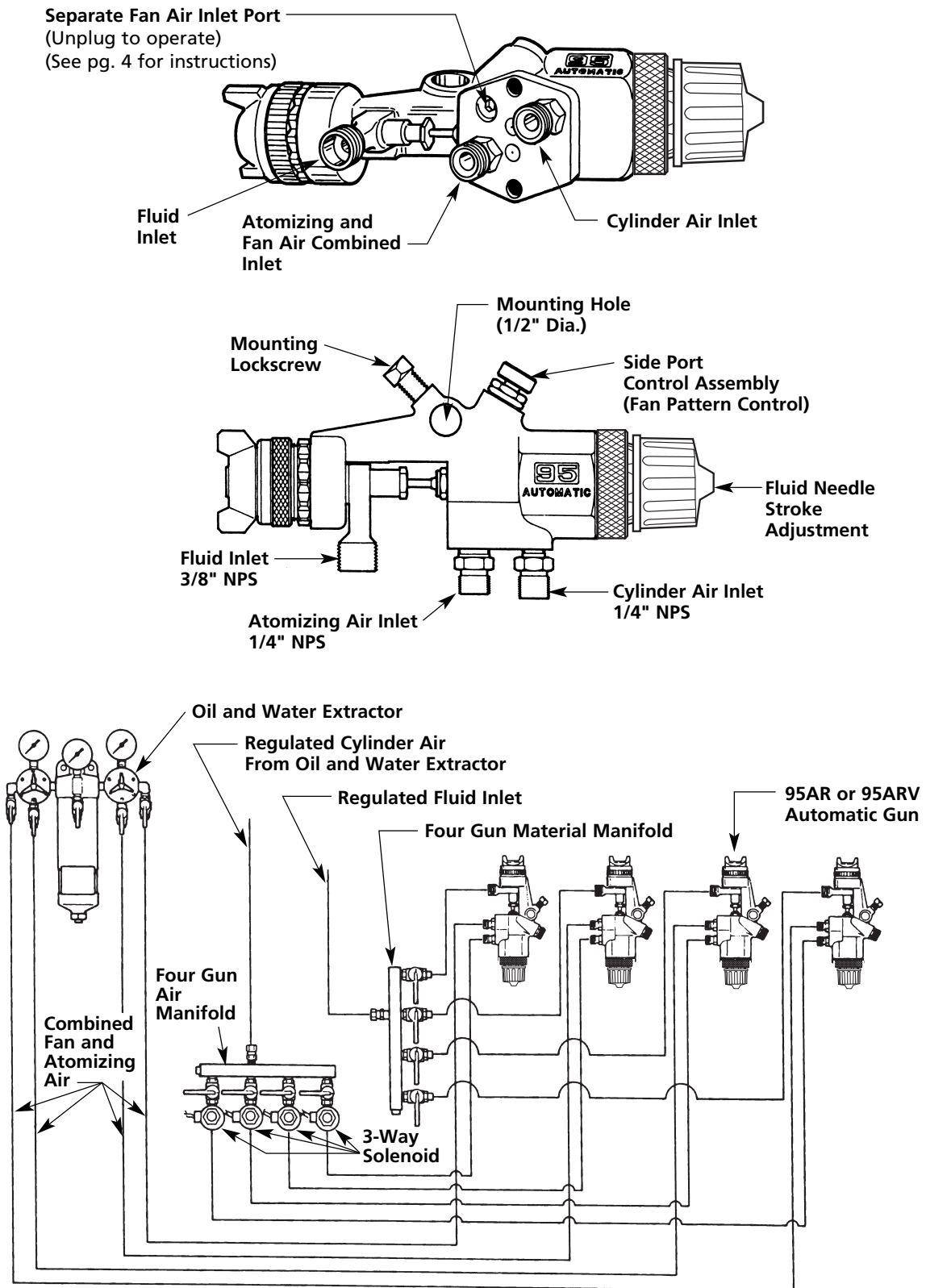

For some applications each gun may require individually regulated fluid and air inlet lines.

Binks Models 95AR and 95ARV AUTOMATIC SPRAY GUNS
Typical Arrangement Diagram and Hook-up for
Separate Fan and Atomizing Air
 (See Page 4 for Internal Modifications to Gun)

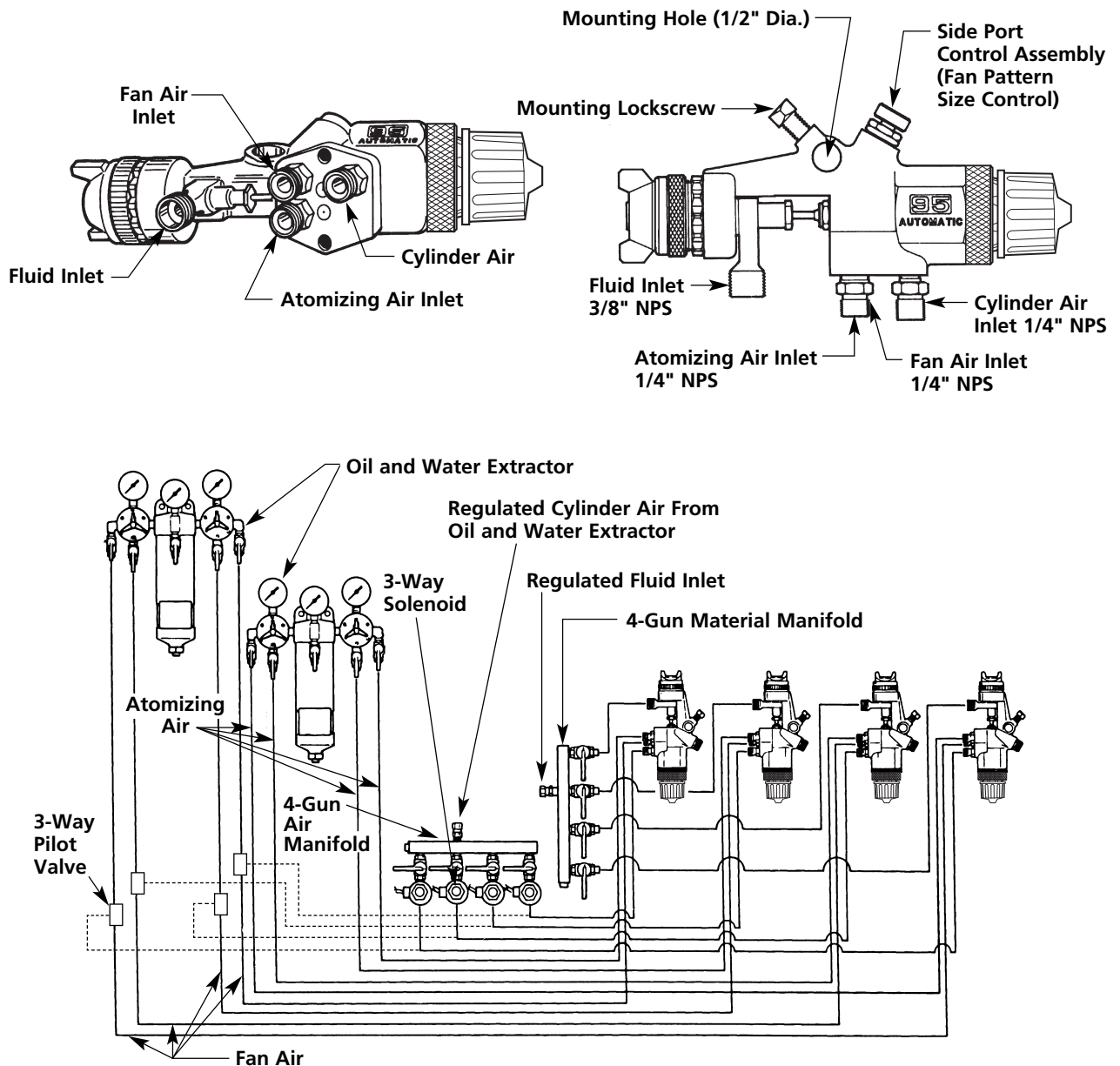

For some applications each gun may require individually regulated fluid and air inlet lines.

GENERAL NOTES

1. Have at least 55-60 P.S.I. air pressure for cylinder's operating air. (Maximum 90 PSIG)
2. To reduce overspray and obtain maximum efficiency, always spray with lowest possible fluid/air pressure that produces an acceptable spray pattern.
3. The air line from gun to 3-way valve should be as short as possible for rapid operation.
4. All air used in the gun should be dirt and moisture free. (This is accomplished by using an oil and water extractor).
5. Shut off all fluid and air lines to gun if gun is to stand idle for any length of time. (This is to prevent "build-up" or accumulation of minute leaks in the system and turning on the gun).

TO CHANGE FROM COMBINED FAN AND ATOMIZING AIR TO SEPARATE FAN AND ATOMIZING AIR

1. Unscrew ratchet housing assembly (28) and remove material needle (22) and attached parts (23, 24, 25) (see assembly drawing page 8).
2. Remove piston assembly (18) by injecting low pressure air into cylinder air port (A).
3. With 5/32" allen wrench, remove plug (16) from hole (B) on inside of cylinder.
4. Insert set screw (50) into position as shown in side cut-away. (Set screw is packaged loose.)
5. Re-install plug (16).
6. Re-install piston (20), 2 springs (26, 27), material needle (22) and ratchet housing assembly (28). (See assembly drawing page 8).
7. Remove plug (47) from the fan air port (C).
8. Install fitting (36) into port (C). (Fitting is packaged loose.)

⚠ WARNING

Use of excessive pressure will cause piston to exit gun body at high velocity, possibly resulting in personal injury or damage to spray gun components. When removing the piston, aim back of gun in a safe direction and do not use excessive air pressure.

NOTE

Double male nipple (36) shipped loose in a separate bag.

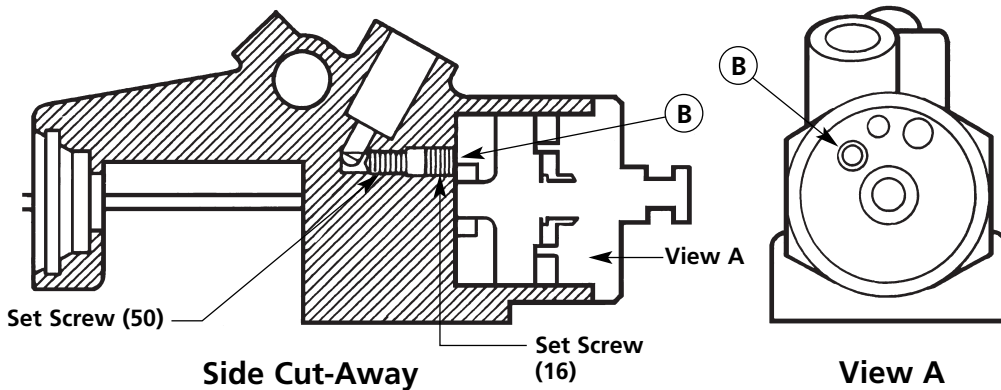
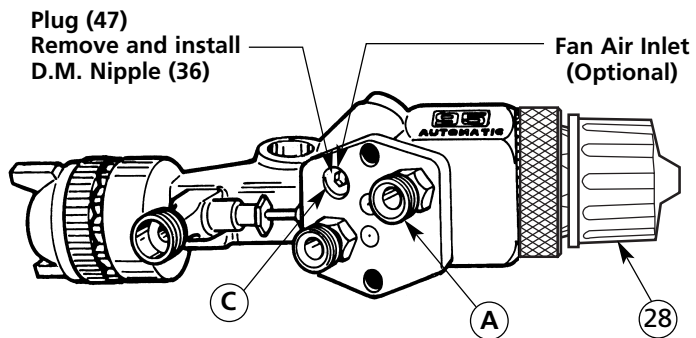

NOTE

Set screw (50) shipped loose in a separate bag.

SETUP FOR SPRAYING

CONNECTING GUN TO MATERIAL HOSE

Gun should be connected by a suitable length of 3/8" diameter material hose fitted with a connector with a 3/8" NPS(f) nut at gun end. 1/4" diameter hose is recommended for use with low viscosity materials. (Fluid hoses of different composition are available for special fluids. See Binks hose catalog for hose selection.)

CONNECTING GUN TO ATOMIZING AIR

Gun should be connected by a suitable length of 5/16"

or 3/8" diameter air hose fitted with a connector and a 1/4" NPS(f) nut at gun end.

CONNECTING GUN TO CYLINDER AIR

Gun should be connected with 3/16" I.D. or 1/8" I.D. air hose of shortest length possible with 1/4" NPS(f) connector. Cylinder air must be connected to a 3-way manual air valve or 3-way solenoid valve to operate properly.

OPERATING THE MODEL 95AR AUTOMATIC SPRAY GUN

CONTROLLING THE MATERIAL FLOW

When fed from a pressure supply, an increase in the material pressure will increase the rate of flow. Correct fluid nozzle size insures correct material flow rate. If necessary, fluid flow can also be adjusted by adjusting the amount of needle travel. This is done by loosening lock nut (29) and adjusting control knob (30) until the correct needle travel is achieved.

ADJUSTING AIR AND FLUID TIMING

A 1/16" gap between the air piston assembly (18) and needle body (24) should be maintained (see figure 1). This will create needle motion that will allow adequate air flow before the fluid starts flowing. The gap may be adjusted by partially removing the material needle (22),

screwing the needle either in or out of the needle body (24) and locking it back into the gun while being sure to check the clearance between the air valve piston (18) and the needle body (24).

ADJUSTING THE SPRAY PATTERN

The width of the spray pattern is controlled by the side port control assembly (7). (See page 8). Turning this control clockwise until it is closed will give a round spray, turning it counterclockwise will widen the spray into a fan shape. The fan spray can be turned anywhere through 360° by positioning the air cap assembly (1) relative to the gun. To effect this, loosen air cap assembly, position nozzle, then, re-tighten air cap assembly.

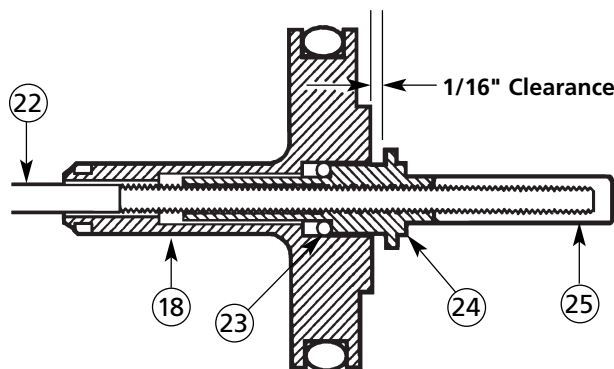

Figure 1

FLUID NEEDLE ADJUSTMENT DIAGRAM



AIR NOZZLE, FLUID NOZZLE AND NEEDLE SELECTION CHART FOR 95AR and 95ARV AUTOMATIC GUNS

TYPE OF FLUID VISCOSITY TO BE SPRAYED	FLUID x AIR NOZZLES	NOZZLE TYPE†	CFM AT * MAX.			PATTERN AT 8"	FLUID NEEDLE
			30 PSI	50 PSI	70 PSI		
VERY THIN VISCOSITY	63SS x 63P	PE	4.5	7.5	10.0	5.0"	763
14-16 Seconds – No. 2 ZAHN Wash Primers Dyes Stains Solvents Water Inks	63ASS x 63P	PE	5.1	8.7	12.2	11.0"	763A
	63BSS x 63PB	PE	9.0	14.3	20.0	14.0"	763A
	66SS x 66SD	SE	7.9	12.1		10.5"	765
	66SS x 66SK	SE	11.0	15.2	19.5	13.0"	765
	63BSSS x 200●	PI	3.1	5.2	6.4	12.0"	763A
THIN VISCOSITY	63ASS x 63P	PE	5.1	8.7	12.2	11.0"	763A
16-20 Seconds – No. 2 ZAHN Sealers Lacquers Primers Inks Zinc Chromates Acrylics Lubricants	66SS x 66SK	SE	11.0	15.2	19.5	13.0"	765
	63BSS x 200●	PI	3.1	5.2	6.4	12.0"	763A
	63BSS X 63PB	PE	9.6	14.3	20.0	14.0"	763A
MEDIUM VISCOSITY	63BSS x 63PB	PE	9.0	14.3	20.0	14.0"	763A
19-30 Seconds – No. 2 ZAHN Synthetic Enamels Varnishes Shellacs Fillers Primers Epoxies Urethanes Lubricants Wax Emulsions	63CSS x 63PR	PE	9.5	15.5	19.5	18.0"	763A
	66SS x 66SD	SE	7.9	12.1		11.0"	765
	66SS x 66SK	SE	11.0	15.2	19.5	13.0"	765
	63CSS x 200●	PI	3.1	5.2	6.4	12.0"	763A
HEAVY (CREAM-LIKE) VISCOSITY	67SS x 206	PI	6.0	9.5	13.0	15.0"	767
Over 28 Seconds – No. 4 FORD House Paint Wall Paint (Oil, Latex) Block Sealers Mill Whites Vinyls Acrylics Epoxies	68SS x 201	PI	4.6	6.8	9.1	11.0"	768
	68SS x 101■	PI	4.6	6.8	9.1	11.0"	768
	66SS x 63PB	PE	9.0	14.3	20.0	14.0"	765
	67SS x 67PB	PE	9.5	14.9	19.5	12.0"	767
	68SS x 68PB	PE	9.5	14.1	19.1	12.0"	768
VERY HEAVY VISCOSITY	68SS x 206	PI	6.2	9.8	13.2	15.0"	768
Unaggregated Block Fillers Textured Coatings Fire Retardants Road Marking Paint Bitumastics Cellular Plastisols	6SS x 68PB	PE	9.5	14.1	19.1	12.0"	768
	59ASS x 244●	PI	7.8	11.5	15.2	12.0"	759
	59BSS x 250●	PI	7.8	11.0	14.7	RND	759
	59BSS x 252●	PI	7.8	11.5	15.2	12.0"	759
ADHESIVES	63CSS x 63PB	PE	9.0	14.3	20.0	14.0"	763A
Waterbase White Vinyl Glue Solvent Base Neoprenes (Contact Cements)	66SS x 63PR	PE	9.5	15.5	19.5	15.0"	765
	67SS x 67PB	PE	9.5	14.1	19.1	12.0"	767
	63SS x 66SD	PE	7.9	12.1	16.2	4.0"	763
	63ASS x 66SD	PE	7.9	12.1	16.2	7.0"	763A
	66SS x 66SD-3	PE	10.4	15.4	20.4	9.0"	765
CERAMICS & SIMILAR ABRASIVE MATERIAL	63CVT x 66PH	PE	11.5	16.4	22.0	13.0"	763VT
Glazes, Engobes Porcelain Enamel	64VT x 64PA	PE	12.1	15.0	21.0	13.0"	764VT
	67VT x 67PD	PE	10.0	15.0	20.0	15.0"	767VT
	68VT X 68PB	PE	9.5	14.1	19.1	12.0"	768VT

*Be certain your air supply is sufficient to operate nozzles selected.

†PE, Pressure feed, external. SE, Siphon feed, external.

PI, Pressure feed, internal.VT, Tungsten Carbide Fluid Nozzles.

■ Tungsten Carbide Air. ● Nitralloy Air Nozzle.

Nozzle No.	59ASS	59BSS	59CSS	63ASS	63BSS	63CSS	65SS	66SS	67SS	68SS
Orifice Size	.171	.218	.281	.040	.046	.052	.059	.070	.086	.110



**NOZZLE AND NEEDLE SELECTION CHART
FOR 95AR and 95ARV AUTOMATIC GUNS (cont.)**

TYPE OF FLUID TO BE SPRAYED	FLUID x AIR NOZZLES	NOZZLE TYPE†	CFM AT *			MAX. PATTERN AT 8"	FLUID NEEDLE
			30 PSI	50 PSI	70 PSI		
CONCRETE CURING COMPOUNDS	63SS x 200●	PI	3.1	5.2	6.4	15.0"	765
	67SS x 206●	PI	6.0	9.5	13.0	18.0"	767
	68SS x 206●	PI	6.2	9.8	13.2	20.0"	768
MULTICOLOR PAINTS	66SS x 200●	PI	3.1	5.2		12.0"	765
	67SS x 206●	PI	6.0	9.5		15.0"	767
TEFLONS	63ASS x 63PB	PE	9.0	14.3	20.0	10.0"	763A
	63BSS x 63PR	PE	9.5	15.5	19.5	15.0"	763A
	66SS x 66SD	SE	7.9	12.1		7.0"	765
HAMMERS	63CSS x 63PB	PE	9.0	14.3		14.0"	763A
	66SS x 63PB	PE	9.0	14.3		14.0"	765
	66SS x 66SD	SE	7.9	12.1		7.0"	765
WRINKLE ENAMELS	63CSS x 63PB	PE	9.0	14.3	20.0	10.0"	763A
	66SS x 63PB	PE	9.0	14.3	20.0	10.0"	765
ZINC RICH COATINGS	66SS x 67PD	PE	12.0	18.0	24.0	15.0"	765N
	67VT x 67PB	PE	9.5	14.1	19.1	12.0"	767VT
SPATTER VEILING DISTRESS	66SS x 66PD	PE	3 at 15 PSI				765
	794SS x 793	PE	3 at 17 PSI				794
	794SS x 797	PE	3 at 15 PSI				794

*Be certain your air supply is sufficient to operate nozzles selected.

†PE, Pressure feed, external. SE, Siphon feed, external.

PI, Pressure feed, internal.VT, Tungsten Carbide Fluid Nozzles.

■ Tungsten Carbide Air. ● Nitralloy Air Nozzle.

Nozzle No.	59ASS	59BSS	59CSS	63ASS	63BSS	63CSS	65SS	66SS	67SS	68SS
Orifice Size	.171	.218	.281	.040	.046	.052	.059	.070	.086	.110

STANDARD PART NUMBERS for 95AR and 95ARV GUNS with Fluid Nozzles and Air Caps and Needles Included.

95AR GUN

6469-2500-795AR GUN 63ASS-63PB 6469-4308-8.....95AR GUN 66SS-66SK
 6469-2800-795AR GUN 63BSS-63PB 6469-5111-5.....95AR GUN 68SS-68PB
 6469-3100-795AR GUN 63CSS-63PB 6469-8219-1.....95AR GUN 59CSS-262
 6469-4307-995AR GUN 66SS-66SD

NOTE

See pgs. 11-12 for 95AR fluid nozzles, air nozzles and needle ordering information. (95ARV below)
 Call 1-800-99-BINKS to order.

95ARV GUN

6487-4909-995ARV GUN 67VT-67PD
 6487-5211-595ARV GUN 68VT-68PB

COMPATIBLE 95ARV GUN NOZZLE SET-UPS (95AR Nozzle set-ups shown on pages 11-12)

TUNGSTEN CARBIDE FLUID NOZZLE DESIGNATION	CARBIDE TIP FLUID NOZZLE PART NUMBER	CARBIDE TIP FLUID NEEDLE DESIGNATION	CARBIDE TIP FLUID NEEDLE PART NUMBER	COMPATIBLE AIR CAPS	AIR CAP PART NUMBER
63CVT	45-6332	763VT	47-762	63P 63PB 63PR 200	46-6000 46-6002 46-6079 46-2200
64VT	45-6402	764VT	47-764	64PA	46-6007
67VT	45-6702	767VT	47-767	67PB 67PD 206 706 709SS 713 797	46-6026 46-6028 46-2206 Tip and 54-1583 Base, 54-1584 Ring 46-2013 Tip and 54-372 Base 46-2020 Tip and 54-372 Base 46-2025 Tip and 54-372 Base 46-156 Tip and 54-372 Base
68VT	45-6802	768VT	47-769	68PB 201 206 706 709SS 713 797	46-6032 46-2201 Tip and 54-1583 Base, 54-1584 Ring 46-2206 Tip and 54-1583 Base, 54-1584 Ring 46-2013 Tip and 54-372 Base 46-2020 Tip and 54-372 Base 46-2025 Tip and 54-372 Base 46-156 Tip and 54-372 Base

Binks Model 95AR, 95ARV AUTOMATIC AIR SPRAY GUN ASSEMBLY DRAWING

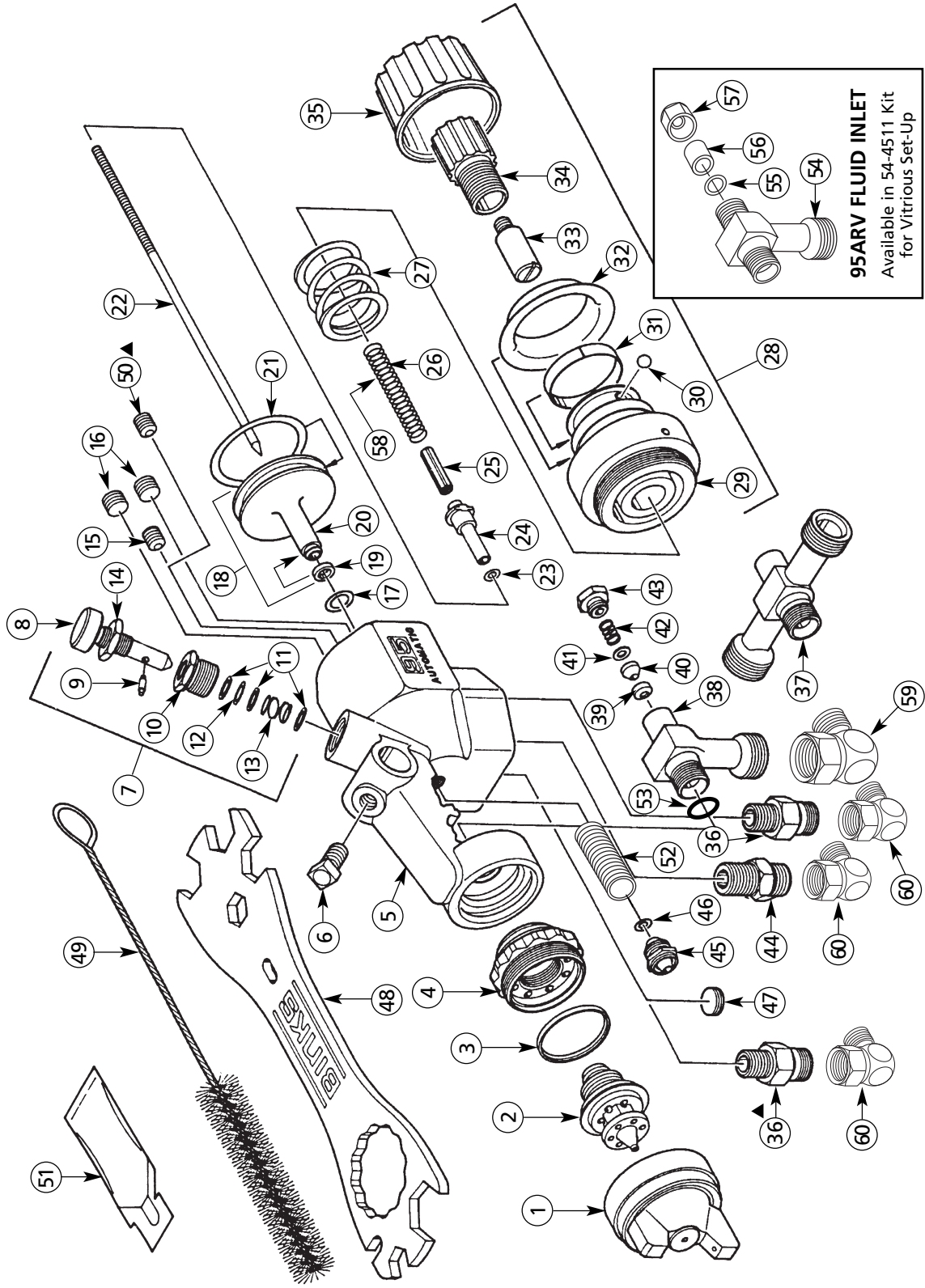

▲ Items (36) and (50) are for installations requiring separate fan and atomizing air control. Items are packaged loose. (See pg. 4)

PARTS LIST

(When ordering, please specify Part No.)

ITEM NO.	PART NO.	DESCRIPTION	QTY.	ITEM NO.	PART NO.	DESCRIPTION	QTY.
1	*	AIR CAP ASSEMBLY.....	1	33	54-3583	SCREW.....	1
2	*	FLUID NOZZLE.....	1	34	54-1879	RATCHET.....	1
3	54-918●▲	SEALING RING.....	1	35	54-1984	CAP.....	1
4	54-4215	HEAD INSERT.....	1	36	71-28	DOUBLE MALE NIPPLE 1/8 NPT x 1/4 NPS.....	2
5	54-4206	95 SERIES AUTO GUN ASSEMBLY	1	37	54-4208	FLUID INLET Recirculating (Optional)..	1
6	20-1359	SQ. HD. BOLT 5/16-18 x 3/4.....	1	38	54-4210	FLUID INLET (95AR Gun).....	1
7	54-3720	SIDE PORT CONTROL ASSEMBLY.	1	39	54-4264●▲	GLAND ADAPTER (95AR Gun).....	1
8	54-3721	CONTROL SPINDLE.....	1	40	54-4265●▲	NEEDLE SEAL (95AR Gun).....	1
9	31-258	RETAINING PIN.....	1	41	54-4266●▲	SEAL BACKUP (95AR Gun).....	1
10	31-256	STUFFING BOX.....	1	42	54-4267●▲	SPRING (95AR Gun).....	1
11	31-259	INNER WASHER.....	3	43	54-4263●▲	PACKING NUT (95AR Gun).....	1
12	20-3620▲	O-RING.....	1	44	57-13	DOUBLE MALE NIPPLE 1/4 NPT x 1/4 NPS.....	1
13	31-241	CONTROL SPRING.....	1	45	54-3716	AIR VALVE GLAND ASSEMBLY....	1
14	54-4269	JAM NUT.....	1	46	20-3859▲	O-RING.....	1
15	54-3987■	PLUG.....	1	47	54-3986■	PLUG 1/8-27 NPT.....	1
16	54-3988■	PLUG 1/16"-20 NPT.....	2	48	54-4213	WRENCH (Optional).....	1
17	20-5286▲	O-RING.....	1	49	82-469	GUN BRUSH.....	1
18	54-3706	PISTON ASSEMBLY.....	1	50	20-2141	SET SCREW 1/4"-20 UNC.....	1
19	54-3729◆▲	SEAL.....	1	51	54-3871	GUNNERS MATE.....	1
20	54-3722◆	PISTON.....	1	52	54-4270	NEEDLE COVER.....	1
21	20-4511▲	O-RING.....	1	53	54-3592●	FLUID INLET SEAL.....	1
22	*	NEEDLE.....	1	54	54-4568★	FLUID INLET (95ARV Gun).....	1
23	20-3515▲	O-RING.....	1	55	20-2227●▲★	O-RING (95ARV Gun).....	1
24	54-3713	NEEDLE BODY.....	1	56	54-4531●▲★	SPACER (95ARV Gun).....	1
25	54-3709	NEEDLE LOCKING NUT.....	1	57	54-4542●▲★	NUT ASSEMBLY (95ARV Gun).....	1
26	54-1697	SPRING Needle Return.....	1	58	54-4096	SPRING Heavy Duty (Optional).....	1
27	54-1876	SPRING Piston Return.....	1	59	73-24	90° S.S. CONNECTION (Optional)....	1
28	54-3582	RATCHET HOUSING ASSEMBLY...	1	60	73-12	90° CONNECTION (Optional).....	3
29	54-3584	RATCHET HOUSING.....	1				
30	20-2183	BALL.....	2				
31	54-1878	SPRING.....	1				
32	54-1870	INDICATOR.....	1				

* See air cap, fluid nozzle and needle selection chart on pages 6-7.
 ● Part of Repair Kit 54-4225 (Fluid inlet & fluid nozzle packing kit).
 ▲ Part of Repair Kit 54-3579 (Fluid inlet, nozzle & piston seal kit).
 ■ Part of gun body assembly (5). ◆ Part of (18). Also available separately.
 ★ Available in 54-4511 Kit for Vitrious Set-Up.

OPTIONAL NOZZLE SET-UPS

ITEM NO.	PART NO.	DESCRIPTION	QTY.	ITEM NO.	PART NO.	DESCRIPTION	QTY.
61	54-1584	RETAINING RING.....	1	66	790	STRAIGHT CORE.....	1
62	54-1583	NOZZLE TIP BASE ASSEMBLY.....	1	67	794SS	FLUID NOZZLE.....	1
63	54-2065	RING.....	1	68	794	NEEDLE ASSEMBLY.....	1
64	659	NEEDLE ASSEMBLY.....	1	69	792	SPIRAL CORE.....	1
65	797	AIR NOZZLE.....	1	70	793	AIR NOZZLE.....	1

INTERNAL MIX HEAVY MATERIAL NOZZLES (OPTIONAL)

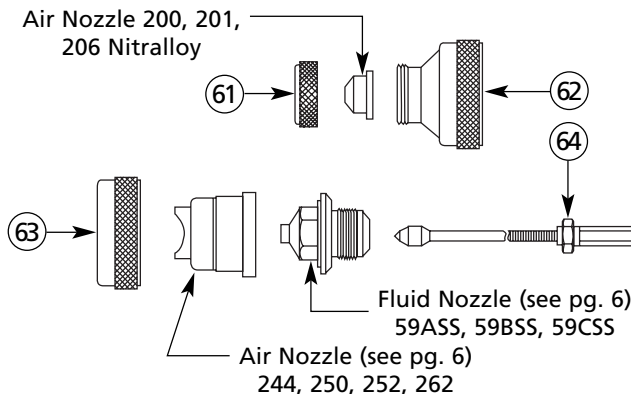

SPECIAL EFFECTS NOZZLES (OPTIONAL)

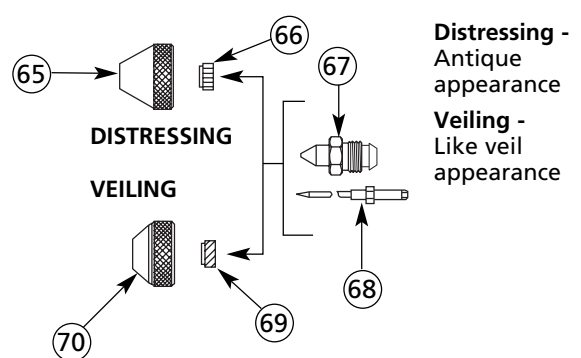

MAINTENANCE

LUBRICATION

Monthly: Remove piston assembly (18) and lubricate the air cylinder chamber and needle valve spring with a coating of Gunners Mate (51). Also, lubricate side port control assembly (7) with oil.

CAUTION

Never use lubricants containing silicone since these lubricants can cause finish defects. Binks Gunners Mate (51) is recommended.

REMOVAL OF PISTON

To remove the piston, first unscrew the ratchet housing assembly (28), remove 2 springs (26 & 27) and pull out the material needle (22) and attached parts (23, 24, & 25). Remove the piston by applying a few pounds of air pressure to the cylinder air inlet. This air pressure will cause the piston to pop out.

WARNING

Excessive air pressure applied to the piston during removal may cause the piston to exit at a high velocity, resulting in personal injury. When removing the piston, aim back of gun in a safe direction and do not use excessive pressure.

TO REPLACE NEEDLE SEAL AND GLAND ADAPTER IN FLUID INLET

Remove ratchet housing assembly (28), springs (26 & 27) and assemble material needle (22) and attached parts (23, 24, & 25). Proceed to the front of the gun and remove air cap assembly (1) and fluid nozzle (2). Then, using wrench (48), unscrew head insert (4) and remove fluid inlet (37 or 38). Unscrew packing nut (43) and remove spring (42) and seal backup (41). Using a no. 10 x 1-1/4" coarse thread wood screw (Binks part no. 20-6536) or small sheet metal screw, remove the needle seal (40) and gland adapter (39). Replace gland adapter (39) and needle seal (40). Reinsert seal backup (41), spring (42) and screw on packing nut (43) a couple of turns so it fits loosely by hand. Reassemble fluid inlet (37 or 38) to gun body (5) with head insert (4). Tighten head insert using wrench (48). Reassemble fluid nozzle (2) and air cap assembly (1). Reinsert material needle (22) and attached parts (23, 24 & 25), springs (26 & 27) and screw on ratchet housing assembly (28). Finally, tighten packing nut (43) until it bottoms out on fluid inlet (37 or 38).

CLEANING

In certain states it is now against the law to spray solvents containing Volatile Organic Compounds (VOCs) into the atmosphere when cleaning a spray gun.

In order to comply with these new air quality laws, Binks recommends one of the following two methods to clean your spray finishing equipment:

1. Spray solvent through the gun into a closed system. An enclosed unit, or spray gun cleaning station, condenses solvent vapors back into liquid form which prevents escape of VOC's into the atmosphere.
2. Place spray gun in a washer-type container. This system must totally enclose the spray gun, cups, nozzles, and other parts during washing, rinsing, and draining

cycles. This type of unit must be able to flush solvent through the gun without releasing any VOC vapors into the atmosphere. Additionally, open containers for storage or disposal of solvent, or solvent-containing cloth or paper, used for surface preparation and clean-up may not be used. Containers shall be non-absorbent.

To clean the gun, flush the fluid lines with solvent and blow air through the air lines to make sure all the air passages are dry.

CAUTION

Never completely submerge the gun in solvent as this will dissolve the lubricating oil and dry out the seals.

TROUBLESHOOTING

FAULTY SPRAY

A faulty spray may be caused by improper cleaning, dried materials around the fluid nozzle tip or in the air cap. Soak these parts in thinners that will soften the dried material and remove with a brush or cloth.

CAUTION

Never use metal instruments to clean the air or fluid nozzles. These parts are carefully machined and any damage to them will cause faulty spray.

If either the air cap assembly (1) or fluid nozzle (2) are damaged, these parts must be replaced before perfect spray can be obtained.

INTERMITTENT SPRAY

If the spray flutters, it is caused by one of the following faults:

1. Insufficient material available. Check supply and replenish if necessary.
2. Loose fluid nozzle (2). Tighten, but without using undue force.
3. Leakage at gland adapter (39) and needle seal (40). Tighten packing nut (43) if loose, and replace gland adapter and needle seal if necessary.
4. Fluid connection insufficiently tight or dirt on cone faces of connection. Correct as necessary.
5. Leaking cylinder air and/or inadequate pressure.

GUN DIMENSIONS

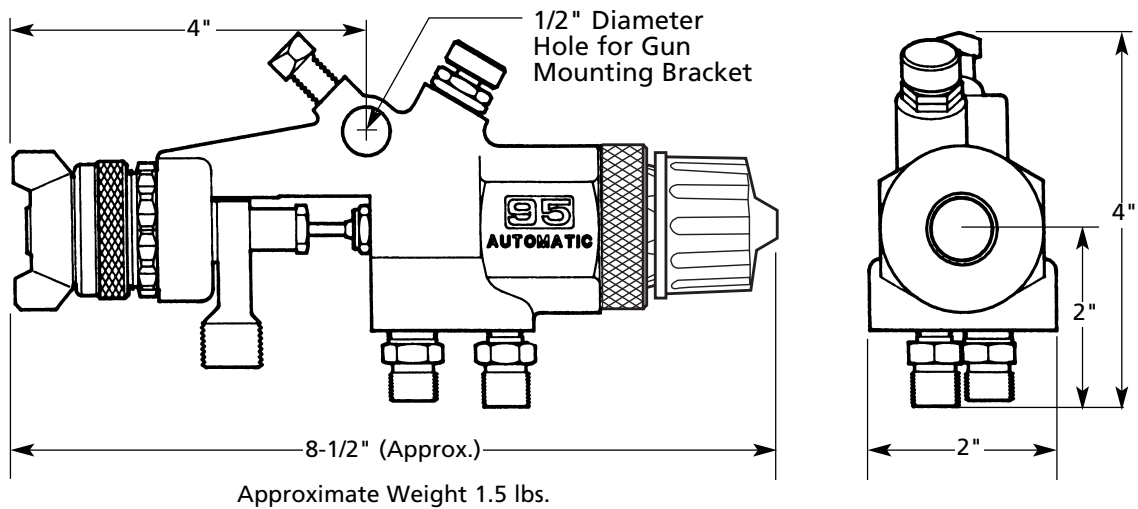

ACCESSORIES (Optional)

MOUNTING BRACKETS

Use for automatic guns. Adjustable to any position. 18" bracket arm. One inch diameter bracket clamp hole for attachment to facility hardware.

54-380 Steel bracket for automatic guns. Shipping weight: 5 lbs.

54-551 Aluminum bracket for automatic guns on reciprocators. Shipping weight: 3 lbs. Part Sheet 1185.

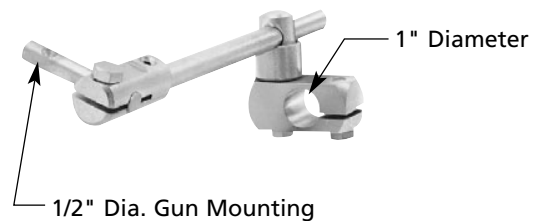

GUN COVER ASSEMBLY

54-3691 Use over the 95AR and 95ARV automatic spray guns to protect them from overspray. Drawing at right shows gun cover with 95A automatic spray gun. (Package of 20 covers).

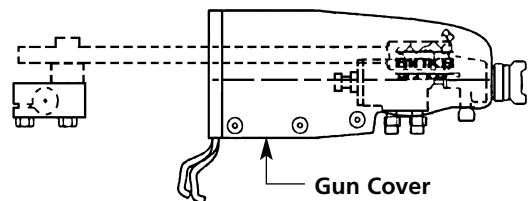

COMPATIBLE 95AR GUN NOZZLE SET-UPS

STAINLESS STEEL FLUID NOZZLE DESIGNATION	STAINLESS STEEL FLUID NOZZLE PART NUMBER	STAINLESS STEEL FLUID NEEDLE DESIGNATION	STAINLESS STEEL FLUID NEEDLE PART NUMBER	COMPATIBLE AIR CAPS	AIR CAP PART NUMBER
62SS	45-6201	762	47-760	63P	46-6000
				63PB	46-6002
				63PR	46-6079
				66PH	46-6016
				66SD	46-6020
				66SD-3	46-6092
				66SK	46-6082
63ASS	45-6311	763A	47-763	63P	46-6000
				63PB	46-6002
				63PR	46-6079
				66PH	46-6016
				66SD	46-6020
				66SD-3	46-6092
				66SK	46-6082

Continued on next page.

COMPATIBLE 95AR GUN NOZZLE SET-UPS (cont.)

STAINLESS STEEL FLUID NOZZLE DESIGNATION	STAINLESS STEEL FLUID NOZZLE PART NUMBER	STAINLESS STEEL FLUID NEEDLE DESIGNATION	STAINLESS STEEL FLUID NEEDLE PART NUMBER	COMPATIBLE AIR CAPS	AIR CAP PART NUMBER
63BSS	45-6321	763A	47-763	63P 63PB 200 201	46-6000 46-6002 46-2200 Tip and 54-1583 Base, 54-1584 ring 46-220 Tip and 54-1583 Base, 54-1584 Ring
63CSS	45-6331	763A	47-763	63P 63PB 63PR 200 201	46-6000 46-6002 46-6079 46-2200 Tip and 54-1583 Base, 54-1584 Ring 46-2201 Tip and 54-1583 Base, 54-1584 Ring
66SS	45-6601	765	47-765	63P 63PB 63PR 66PD 66PE 66PH 66R 66S 66SD 66SD-3 66SK	46-6000 46-6002 46-6079 46-6013 46-6014 46-6016 46-6041 46-6018 46-6020 46-6092 46-6082
67SS	45-6701	767	47-766	67PB 67PD 706 709SS 713 797	46-6101 46-6028 46-2013 Tip and 54-372 Base 46-2020 Tip and 54-372 Base 46-2025 Tip and 54-372 Base 46-156 Tip and 54-372 Base
68SS	45-6801	768	47-768	68PB 201 206 706 709SS 713 797	46-6032 46-2201 Tip and 54-1583 Base, 54-1584 Ring 46-2206 Tip and 54-1583 Base, 54-1584 Ring 46-2013 Tip and 54-1583 Base, 54-1584 Ring 46-2020 Tip and 54-372 Base 46-2025 Tip and 54-372 Base 46-156 Tip and 54-372 Base
59ASS	45-5911	759	47-75900	244	46-2244 Tip and 54-2065 Ring
59BSS	45-5912	759	47-75900	250 252	46-2250 Tip and 54-2065 Ring 46-2252 Tip and 54-2065 Ring
59CSS	45-5913	759	47-75900	262	46-2262 Tip and 54-2065 Ring
L6SS	45-6605	765	47-765	63P 63PB 66PD 66PE 66PH 66S 66SK	46-6000 46-6002 46-6013 46-6014 46-6016 46-6018 46-6082

ITW Industrial Finishing

Binks has authorized distributors throughout the world. For technical assistance or the distributor nearest you, see listing below.

U.S./Canada Technical Service Office:

195 Internationale Blvd., Glendale Heights, IL 60139
Toll-Free Telephone: 1-888-992-4657 (U.S.A. and Canada only)
Toll-Free Fax: 1-888-246-5732



An Illinois Tool Works Company

**Binks Worldwide Sales and Service Listing:
www.binks.com**

WARRANTY

This product is covered by Binks' 1 Year Limited Warranty.

77-2655R-2 Revisions: (P2 & 3) Updated Hook-up diagrams; (P7) Updated Standard Part Numbers for 95AR and 95ARV Guns.