

Binks MODEL 84-600 BACK PRESSURE VALVE
1 1/2" NPT, Stainless Steel, Low Shear

NOTE: Item #17. To Be
Tightened To 150 Inch Pounds.

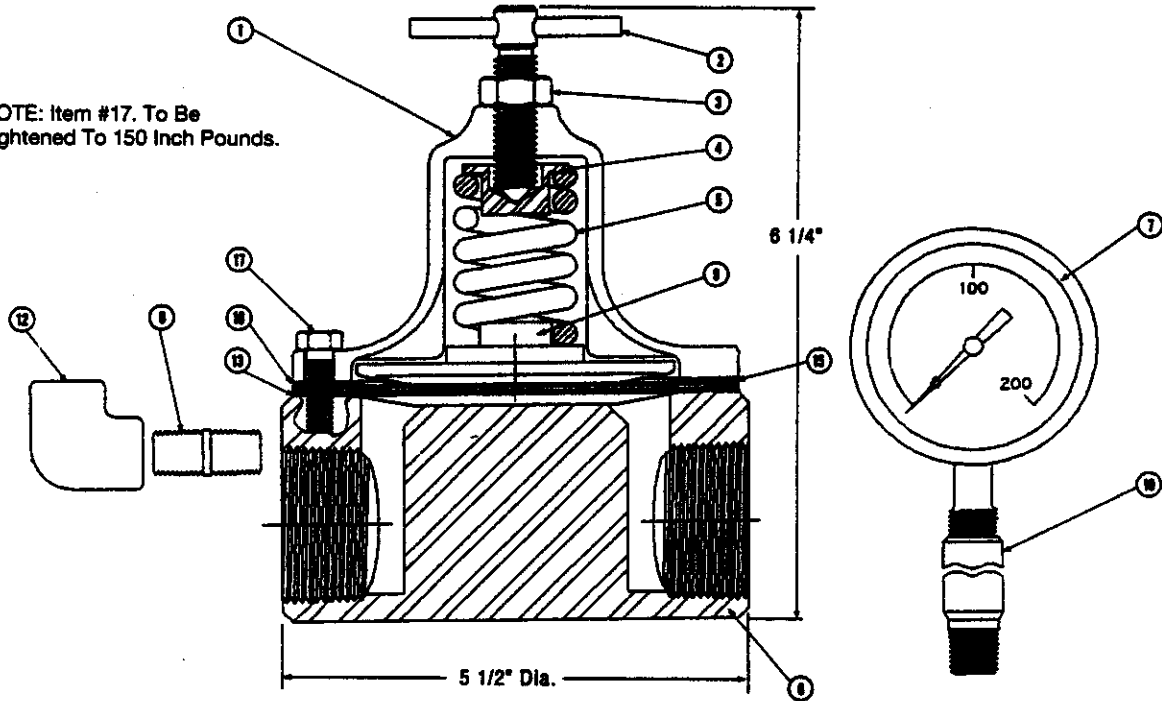

PARTS LIST

(When ordering, please specify PART NO.)

ITEM NO.	PART NO.	DESCRIPTION	QTY.
1	84-367	BONNET	1
2	84-378	HANDLE	1
3	20-262	NUT, 1/2-13	1
4	84-384	BUTTON	1
5	84-374	SPRING	1
6	84-559	BODY, 316 S.S.	1
7	83-2744	GAUGE—200# (S.S.)	1
8	20-5632	NIPPLE, 1/4 NPT	1
9	84-562	DISC	1
10	84-348	CONNECTOR	1
11			
12	20-2848	ELBOW, 1/4 NPT	1
13	84-563	DIAPHRAGM, Teflon	2
14			
15	84-564	DIAPHRAGM, Nylon	2
16	84-386	GASKET	1
17	20-1596	5/16-18 x 7/8" HEX. HD. CAP SC.	8

Weight = 12.0 Lbs. (5.44 Kgs.)
 Flow (Max.) = 8.0 GPM
 Back Press. (Max.) = 130 PSIG
 Flow Coefficient (Cv) = .60

GPM (Q) = Flow Coeff. (Cv) $\sqrt{\frac{\text{In (PSIG)} - \text{Out (PSIG)}}{\text{Specific Gravity (S.G.)}}}$

Binks Manufacturing Company, 1994. All Rights Reserved.



MANUFACTURING COMPANY
 9201 Belmont Avenue, Franklin Park, IL 60131-2887

Part Sheet
2629

Binks MODEL 84-601 BACK PRESSURE VALVE
1/2" NPT, Stainless Steel, Low Shear

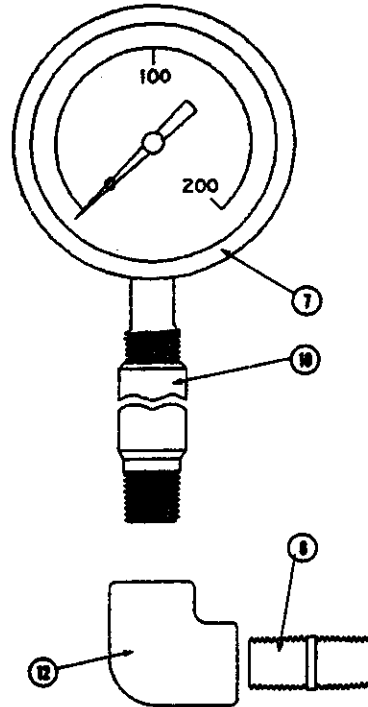
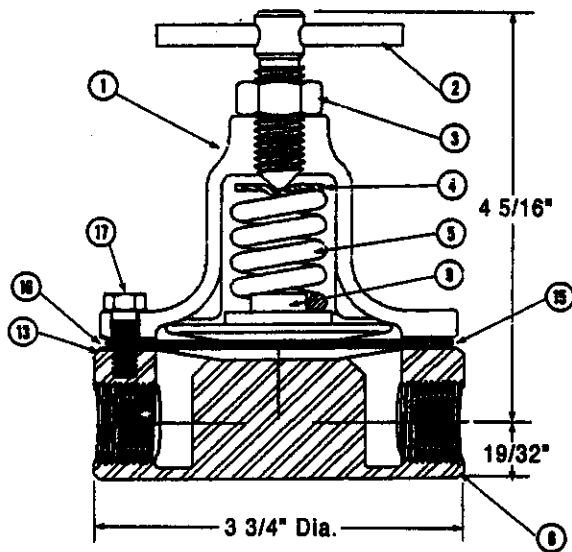

PARTS LIST

(When ordering, please specify PART NO.)

ITEM NO.	PART NO.	DESCRIPTION	QTY.
1	84-359	BONNET	1
2	84-351	HANDLE	1
3	20-262	NUT, 1/2-13	1
4	85-10	BUTTON	1
5	84-365	SPRING	1
6	84-569	BODY, 316 S.S.	1
7	83-2744	GAUGE—200# (S.S.)	1
8	20-5632	NIPPLE, 1/4 NPT	1
9	84-565	DISC	1
10	84-348	CONNECTOR	1
11			
12	20-2848	ELBOW, 1/4 NPT	1
13	84-566	DIAPHRAGM, Teflon	2
14			
15	84-567	DIAPHRAGM, Nylon	2
16	84-463	GASKET	1
17	20-537	1/4-20 x 3/4" HEX. HD. CAP SC.	6

Weight = 3.0 Lbs. (1.36 Kgs.)
 Flow (Max.) = 1.0 GPM = 60 Feet/Min.
 Back Press. (Max.) = 130 PSIG
 Flow Coefficient (Cv) = .20

NOTE: Item #17. To Be Tightened To
 90 Inch Pounds.

$$GPM (Q) = \text{Flow Coeff. (Cv)} \sqrt{\frac{\text{In (PSIG)} - \text{Out (PSIG)}}{\text{Specific Gravity (S.G.)}}}$$