

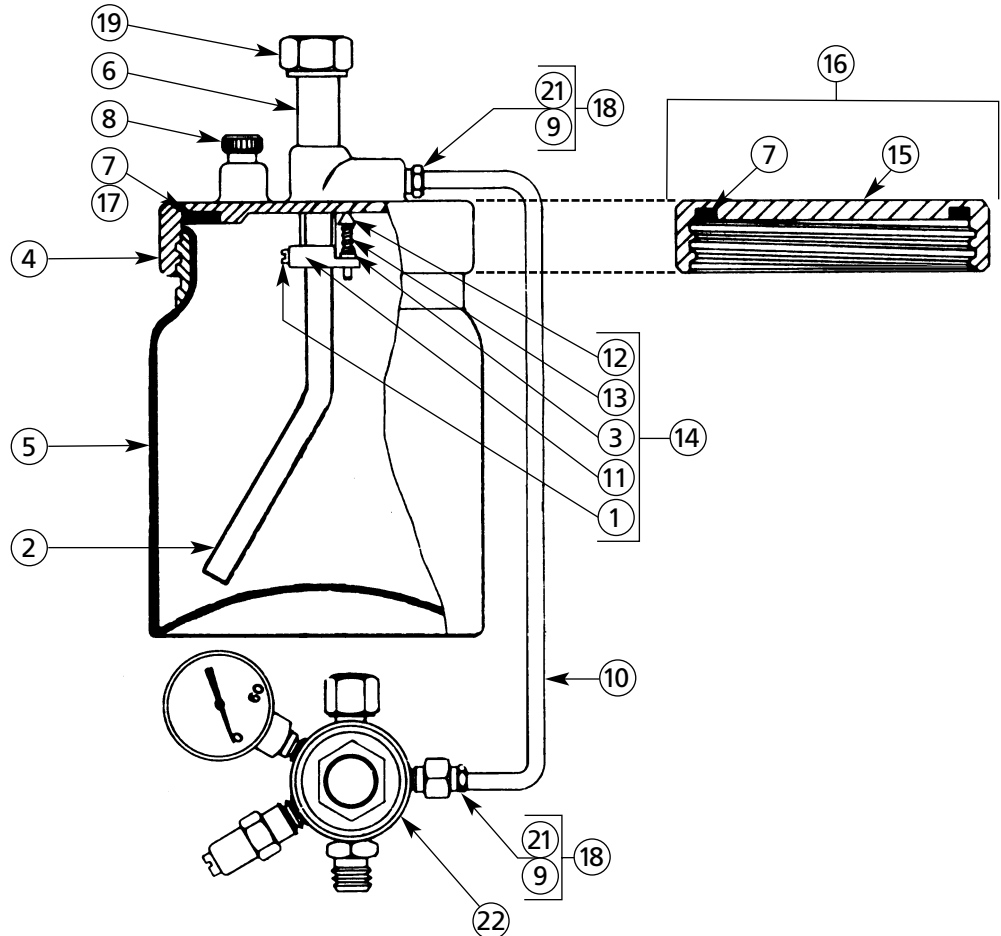

Binks Model 80-210 ONE QUART PRESSURE CUP

(For use with Models 18, 370A & 2001 Spray Guns)



PARTS LIST

When ordering, please specify Part No.

ITEM NO.	PART NO.	DESCRIPTION	QTY.	ITEM NO.	PART NO.	DESCRIPTION	QTY.
1	20-6299	SET SCREW, SLOTTED HEAD 1 6-32 X 1/4 IN. LONG	1	11	80-24	CHECK VALVE BODY	1
2	57-120	FLUID TUBE..... 1	1	12	80-25	CHECK VALVE	1
3	57-125	CHECK VALVE WASHER	1	13	80-26	CHECK VALVE SPRING	1
4	80-1	CUP COVER..... 1	1	14	80-27	CHECK VALVE KIT..... 1	1
5	80-3	CUP	1	15	80-42*	COVER..... 1	1
6	80-8	CENTER POST	1	16	80-43*	COVER ASSEMBLY	1
		MODELS 18, 69, 370A & 2001 GUNS		17	80-45*	COVER GASKET, LEATHER..... 1	1
7	80-11	COVER GASKET, TRI-SEAL FOAM	1	18	80-357	CONNECTOR KIT..... 2	2
8	80-12	RELIEF VALVE	1	19	82-212	SWIVEL NUT	1
9	80-14	AIR TUBE NUT	2	20	82-350	AIR CONNECTION SWIVEL NUT..... 1	1
10	80-16	AIR TUBE..... 1	1	21	85-352	AIR TUBE SLEEVE	2
		MODELS 18, 370A & 2001 GUNS		22	85-221	PRESSURE REGULATOR, COMPLETE 1	1

*Optional, please order separately.

NOTE

For 80-211, 80-256 & 80-257 Pressure Cups, see P/S 1149R-18.

Replaces
Part Sheet
1149R-18

Part
Sheet
1149R-19

Binks MODEL 85-221 AIR PRESSURE REGULATOR

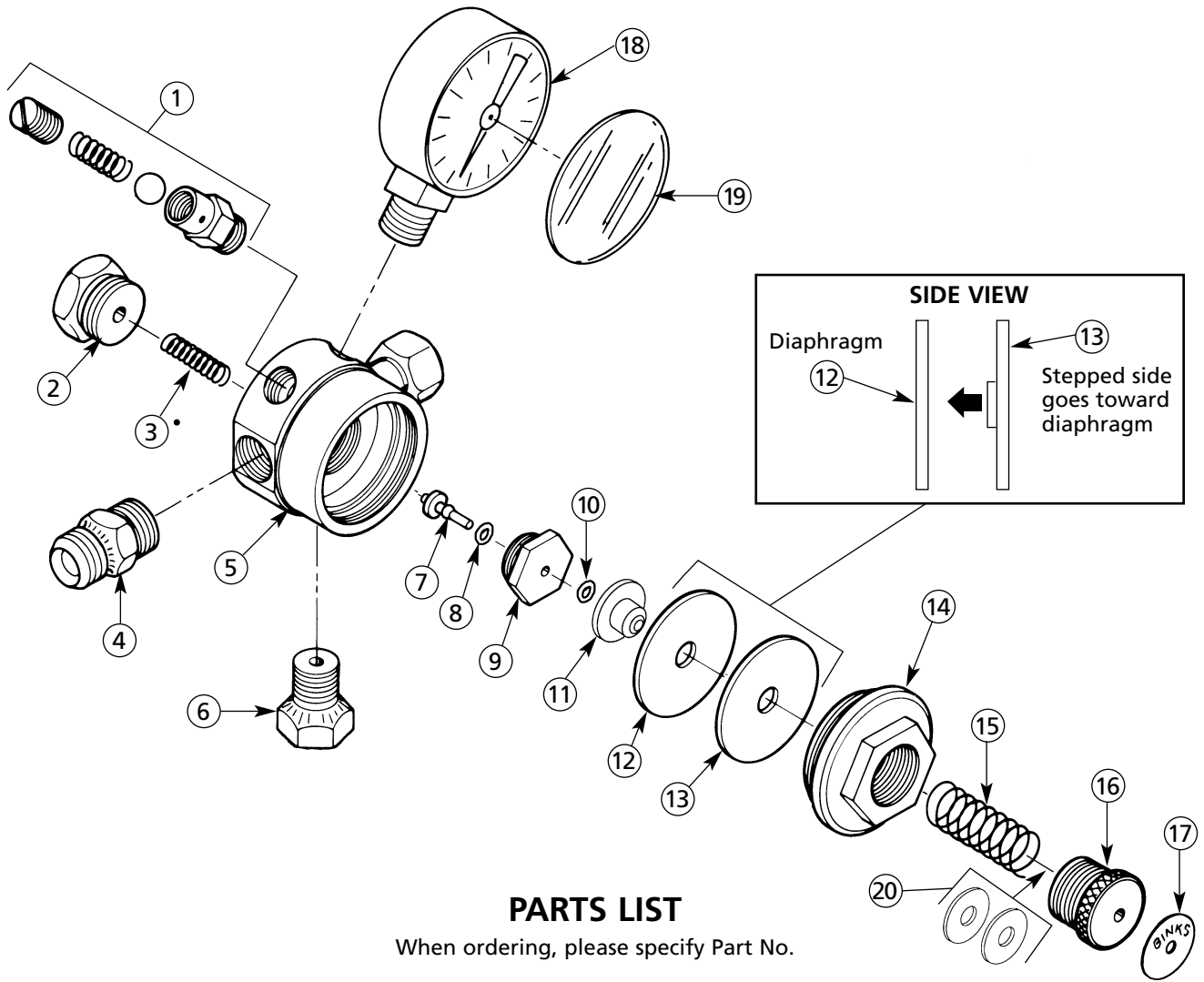

PARTS LIST

When ordering, please specify Part No.

ITEM NO.	PART NO.	DESCRIPTION	QTY.	ITEM NO.	PART NO.	DESCRIPTION	QTY.
1	85-84	SAFETY VALVE ASSY. (35 PSI)	1	11	85-262★•	DIAPHRAGM RETAINER	1
2	85-179▲	REAR CAP.....	1	12	85-183-5★■	DIAPHRAGM	1
3	54-1637★•	VALVE SPRING	1	13	85-267★•	WASHER.....	1
4	54-308	AIR CONNECTION 1/4" NPS	1	14	85-184•	FRONT CAP	1
5	85-81•	REGULATOR BODY	1	15	85-80	SPRING	1
6	85-85▲	CONNECTION.....	1	16	85-46•	ADJUSTING CAP	1
7	85-259★	VALVE.....	1	17	85-197	LABEL	1
8	20-6288★	O-RING (2-004 EPR)	1	18	85-70•	AIR GAUGE (60 PSI)	1
9	85-181★•	VALVE SEAT	1	19	85-130-5■•	GAUGE LENS (For Replacement)	1
10	20-6683★▲	O-RING (2-003 EPR)	1	20	54-329★•	WASHER (Brass)	2

★ Parts furnished in 85-186 Kit. ▲ Items NOT available separately. • Industrial Finishing distributors only. ■ Available as a Quantity Pack.

Sales and Service Through a Nationwide Network of Industrial Distributors.

Customer Service in USA / 1-800-992-4657
Technical Support in USA / 1-888-992-4657

BINKS
 195 Internationale Blvd.
 Glendale Heights, IL 60139

1149R-19 Revisions: Updated graphic standards; (P1) Removed references to 80-22 Air Connection, Parts List and diagram revised; (P2) Replaced art and Parts List for 85-221; removed note regarding Conversion Kit 85-186 (now a Repair Kit), changed pressure of 85-84 gauge to 35 PSI.