



# PUMP MOUNTING HARDWARE

Graco provides a complete line of pump mounting hardware – from clamps, wall brackets, covers, elevators, and rams to a variety of stands and carts. So whether you need to mount your pump on the wall, on a drum, or move it to many locations, Graco gives you rugged hardware to fit your Graco pump for every application.

- **Sturdy wall mount brackets save floor space & enable container changes.**
- **Elevators conveniently raise and lower heavy pumps.**
- **Rams provide pump support while pressure-feeding pumps.**
- **Carts & dollies make your pumps portable.**
- **Stationary stands, wheel kits, and bases provide added flexibility.**
- **Reinforced, heavy gauge drum covers support pumps on open drums.**
- **Drum & tank clamps stabilize your pumps on the fluid container.**

# Wall Brackets & Plates

Quality-made wall shelf brackets support pumps and free-up floor space. Choose the one that's right for your pump.

Part No.	Graco Pump Support	Features	Material	Inst. Manual
210-881	Fast-Flo	Sturdy, compact	Cast iron	307-427
224-835	Husky 307 & 715	Wall mount, pump mounting holes	Painted steel	307-855
189-233	Husky 1040	Rigid 11 ga. wall bracket	Painted steel	—
203-987	Fast-Flo 1:1 Fire-Ball 5:1 Dyna-Star 1:1 Eagle 3:1 President 10:1	Mounts pumps with 2½ in. (54 mm) dia. riser tubes. Steel strap for securing pump to cast iron V-Block.	Steel, cast iron	306-508
236-778	Dyna-Star ¼:1 Power-Star 1:1 President 3:1	Mounts pumps with 4 in. (102 mm) dia. riser tubes. Steel strap for securing pump to cast iron V-Block.	Steel, cast iron	308-394
206-778	Monark, President and Viscount in-line and 3-tie-rod divorced stubby pumps	Includes all screws, washers and nuts for fastening pump to bracket.	Painted steel	306-783
207-365	Monark, President and Viscount in-line and 3-tie-rod divorced stubby pumps	Includes all screws, washers and nuts for fastening pump to bracket.	Painted steel	306-783
206-220	Monark, President and Viscount II stanchion tube divorced pumps	Includes all fittings for mounting pumps and paint filter. Order 206-108 adapter plate (below) separately to mount 3-tie-rod divorced stubby pumps.	Painted steel	306-783
206-221	Husky 1030, Senator, Bulldog, King, Viscount II 3-tie-rod divorced stubby pumps; Glutton, mid-range High-Flo	Includes gasket, screws, washers and nuts for fastening pump to bracket.	Painted steel	306-783
206-108	Monark and Viscount I	Adapts Monark 3-tie-rod divorced stubby pump to fit 206-220 bracket or 207-373 drum cover.	Painted steel	306-783
184-565	Premier	Bracket only. Pump front loads for easy mounting – minimizes lifting.	Painted steel	308-214
205-740	Dual stanchion tube for Monark, President and Viscount to either stand 205-640 or 205-700	Provision for mounting paint filter/outlet manifold.	Steel	—

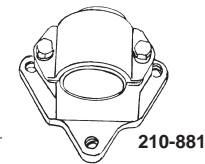

210-881

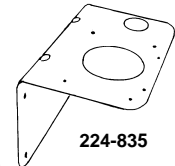

224-835

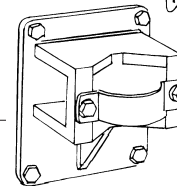

203-987  
236-778

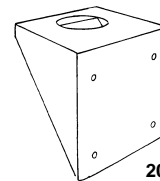

206-778

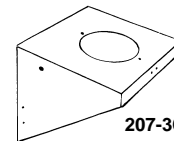

207-365

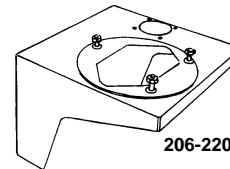

206-220

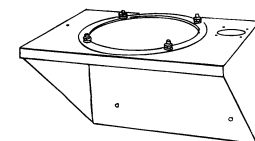

206-221

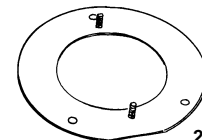

206-108

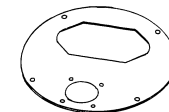

205-740

## Wall Brackets & Plates (continued)

Part No.	Graco Pump Support	Features	Material	Inst. Manual
184-140	Check-Mate pumps	Used with 222-781 ram.	Painted steel	308-026
162-225	Monark and President pumps	Used with 206-450 ram.	Painted steel	—

## Elevators, Tubes and Controls

Provides pump support when pump is raised and lowered to change pails or drums. Many models to fit your containers.

### 10 Gallon (38 Liters) Pail Elevators

Part No.	Graco Pump Support	Features	Material	Inst. Manual
205-332	Use with 10 gallon (38 liters) cover 207-704	Air fitting for quick coupler and restrictor valve.	Steel	306-466
203-664	Monark or President divorced design, inductor type pumps	Order pail truck 203-650 separately to use with Fire-Ball, Monark and President pumps.	Steel	306-472
204-124	Fast-Flo, Fire-Ball	Includes cover 204-123 and elevator 205-332.	Painted steel	306-522

### 16 Gallon (61 Liters) Drum Elevators

Part No.	Graco Pump Support	Features	Material	Inst. Manual
204-121	Fire-Ball	Use with 204-123 cover to mount Fire-Ball pumps to 120 lb. drum.	Steel	306-522

### 5 Gallon Inductor Plate

Part No.	Graco Pump Support	Features	Material	Inst. Manual
206-747	Fits collar 2.69 in. ID	—	Steel	—



205-332

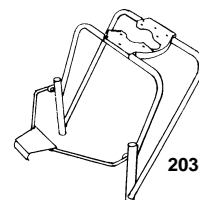

203-664

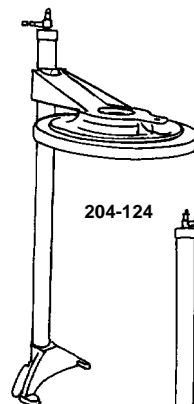

204-124



204-121

## 55 Gallon (210 Liters) Drum Elevators

Part No.	Graco Pump Support	Features	Material	Inst. Manual
237-747	Fire-Ball, Monark and President	Includes elevator 206-231, pump support 237-578, and air control kit 237-579.	Steel	306-287
237-746	Fire-Ball, Monark, and President cover-mounted pumps	Includes elevator 204-385, air control valve 237-579, floor mount base 204-385, and drum cover support 237-578.	Steel	306-287
204-352	Fire-Ball, Monark and President in-line and divorced design pumps without drum cover or bung adapter	Includes elevator 204-385, and bracket 204-510.	Steel	306-568
204-385	Fire-Ball, Monark and President	Elevator only with stationary base.	Steel	306-287
237-902	Bulldog, King	Includes elevator 207-408, pump support 237-578, and air control kit 237-579.	Steel	306-287
237-525	Elevator Retrofit Kit	Designed to adapt elevators with old support ring to fit new SST drum covers 237-306 thru 237-310, 190-206, 238-008 and others.	Steel	308-467

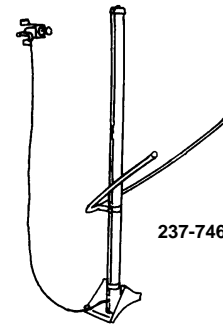
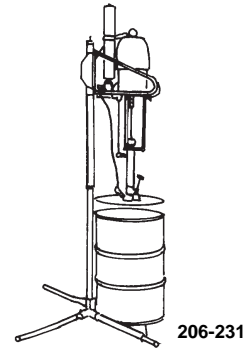

## 55 Gallon (210 Liters) Drum Elevator Base Plates

Part No.	Features	Material	Inst. Manual
205-339	Provides stable surface if floor is too irregular for proper operation. Use with 207-408 and 204-385.	Steel	306-556
206-299	Same as 205-339 except for use with 206-231.	Steel	306-781

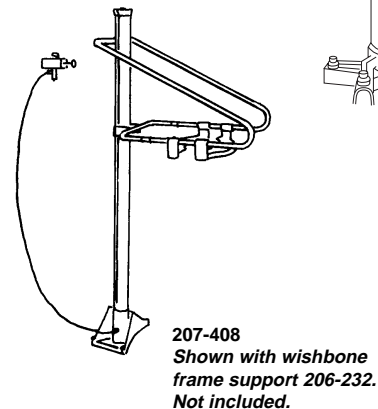
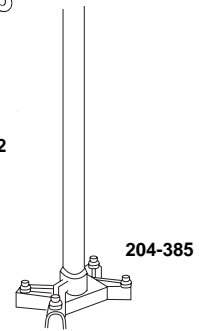
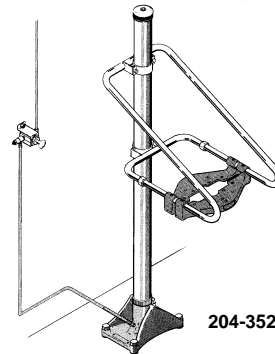

## 55 Gallon (210 Liters) Drum Inductor Assembly

Inductor assemblies include elevator, pump bracket, inductor plate, up/down control, air hose and floor base plate.

Part No.	Features	Material	Inst. Manual
204-490	Monark (224-350) and President (224-348). Includes elevator, inductor plate, pump bracket, up/down control, air hose and steel base. Requires pump adapter 161-251. Also requires flange (160-754).	Steel	306-556
204-564	Bulldog 20:1 (222-527) and King 55:1 (222-545). Features same as 204-490.	Steel	306-882
207-039	Bulldog 5:1 (221-104), 30:1 (221-064) and King 45:1 (221-063). Features same as 204-490.	Steel	306-882
222-635	Bulldog 10:1 (224-176), King 20:1 (224-178)	Steel	306-882

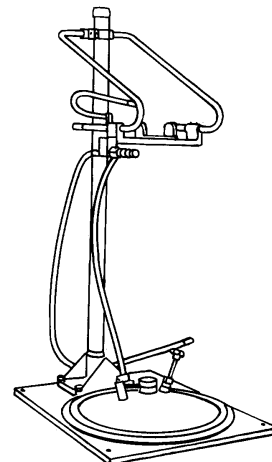

204-490

## 55 Gallon (210 Liters) Drum Inductor Plates

Part No.	Features	Material	Inst. Manual
204-405	Fits collar 2.22 in. ID. For Check-Mate Bulldog 12:1 and King 24:1. Always order lug adapter kit (222-776).	Steel, rubber	—
204-562	Fits collar 2.69 in. ID.	Steel, rubber	—
205-440	Flange	Steel	—

## 55 Gallon (210 Liters) Drum Cover Lift Support

Part No.	Features	Material	Inst. Manual
237-578	For drum cover-mounted pumps. Requires support arms to attach cover to elevator. Fits 204-385, 237-902 and 237-747.	Painted steel	306-287

## 55 Gallon (210 Liters) Drum Wishbone Frame Support

Part No.	Graco Pump Support	Features	Material	Inst. Manual
204-510	Fire-Ball, Monark and President in-line pump	Wishbone support and controls for up/down.	306-568	—
206-232	Bulldog and King	Adjustable bracket attaches to elevator tube 207-408.	Zinc-plated steel	306-287

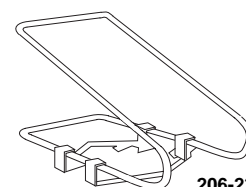

206-232

## 55 Gallon (210 Liters) Air Control Kits

Part No.	Graco Pump Support	Features	Inst. Manual
206-276	Bulldog or King pump mounted on a heavy-duty elevator	Includes air regulator with gauge restrictor valve, push-pull valve, air-assist valve, hose and fitting for directing air to pump, elevator and inductor plate.	—
207-561	—	Elevator up/down control.	306-287
237-579	—	Air control kit similar to 206-276; plus includes air tube and mounting bracket to locate push-pull control on front edge of new stainless steel drum cover.	306-287

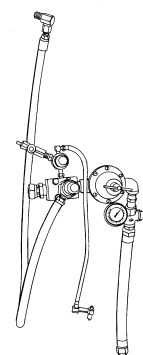

206-276

## Pail Carts

For job site mobility, Graco offers compact, stable carts and dollies. Available with various frame and tire sizes.

### Portable Carts

Part No.	Graco Pump Support	Features	Material	Inst. Manual
203-650	5 and 10 gallon (19 and 38 liter) pails	Two wheel cart with handle. Holds pail with pump. Use with 203-664 or 207-704.	Painted steel, rubber wheels	306-436
238-938	Monark, President and Viscount II with 3-tie-rod design and displacement pump length less than 20.5 in. (52 cm)	Compact, stable cart pneumatic tires, double grip handle, heavy-duty support pads. Handle supports large hose coil.	Painted steel, rubber wheels	308-136
240-223	Monark Stubby, 307 Husky	Light duty cart features single handle, hose hook pump/air control bracket	Painted steel, rubber wheels	308-762
238-271	Senator, Bulldog, King and Viscount II with fluid displacement pump length less than 30 in. (76 cm)	Same construction as 224-044 but more strength for heavier pumps and large hose coils.	Painted steel, rubber wheels	308-136
218-028	Senator, Bulldog, King and Viscount II with fluid displacement pump length less than 30.5 in. (77 cm)	Well-balanced frame. Large pneumatic wheels. Siphon tube holder. Handle accommodates large hose coil.	Painted steel, rubber wheels	307-629
224-137	Exclusively for Check-Mate pumps	Same as 203-650 plus air lift elevator for raising pump.	Painted steel, rubber wheels	308-092
236-943	Premier Big Rig	Welded frame	Painted steel, rubber wheels	—

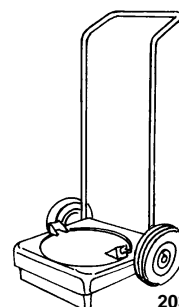

203-650

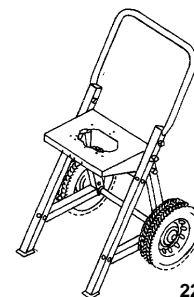

224-044

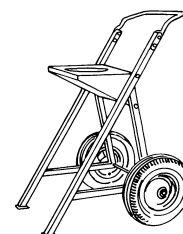

218-028

### Band Dolly

Part No.	Graco Pump Support	Features	Material	Inst. Manual
205-054	5 gallon (19 liter) pails	Attaches to pail base. Large swivel wheels.	Painted steel, rubber wheels	306-566
204-144	10 and 16 gallon (38 and 61 liter) drums. Also 5, 10, 15 gallon (19, 38, 56.8 liters) pressure pots.	Attaches to pail base. Large swivel wheels.	Painted steel, rubber wheels	307-879

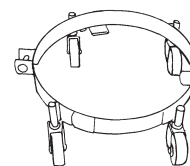

205-054

# Pump Rams

Stable, secure ram designs hold pumps in place during operation or above container while changing containers. Available in pail and drum styles. Puts pressure on high viscosity fluid surface to force material into pump inlet.

## 5 Gallon (19 Liter) Single Post Pail Ram

Part No.	Graco Pump Support	Features	Material	Inst. Manual
206-450	Senator, Bulldog and King. Use adapter plate 162-225 to support Monark and President.	Supports pump on pneumatic post. Pump bracket, air regulator, 5 gallon (19 liters) pail ram and welded floor plate, ram wiper plate.	CS	306-838
222-781	Exclusive use with Check-Mate pumps. Use adapter plate 184-140 to support Monark and President.	Same as 206-450.	CS	306-838

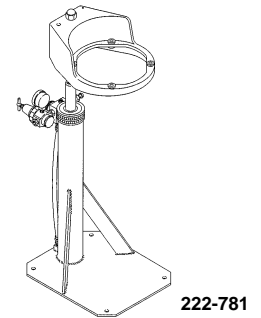
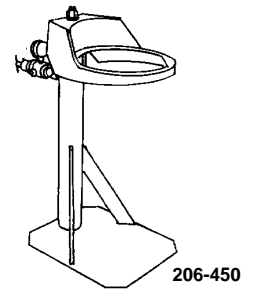

## 5 Gallon (19 Liter) Two Post Pail Ram

Part No.	Graco Pump Support	Features	Material
918-495	Bulldog, King and Viscount II	Extra sturdy design. Dual pneumatic posts for extra pressure needed for viscous fluid evacuation through pump inlet. Air controls included. (Order air regulator and ram follower plate separately.)	Painted steel

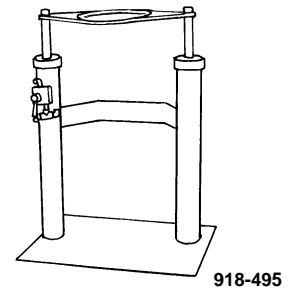

## 5 Gallon (19 Liter) Plate Shields

Part No.	Features	Material
223-689	Ten disposable shields for 5 gallon (19 liter) pails.	Polyethylene

## 55 Gallon (210 Liter) Two Post Drum Rams

Part No.	Graco Pump Support	Features	Material	Inst. Manual
207-279	Monark, President, Senator, Bulldog and King pumps. Fits all Check-Mate and Dura-Flo pumps. Requires 222-776 mounting kit. Adapter plate 162-225 required to mount Monark and President.	Includes ram unit, adjustable pump mount, 55 gallon (210 liter) ram plate with double wiper rings, air controls, and 42 in. x 25 in. (107 cm x 63 cm) base plate. (Order air regulator separately.)	Painted steel	306-934
236-726	Wiper Ring Replacement Kit. Easy to install. Superior wiping performance. Kit for 207-279 ram plate includes two wiper rings and four retainer bands.			
948-103	All Graco sanitary pumps	Sanitary use. (Order tie rods and ram plate separately.)	White epoxy	—

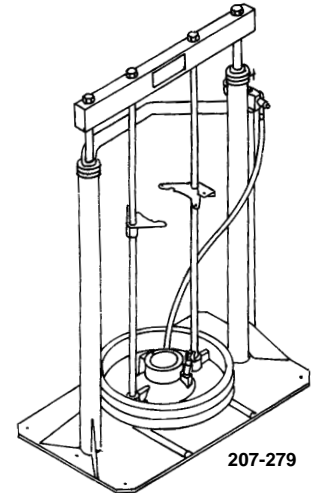

## 55 Gallon (210 Liters) Drum Clamps

Part No.	Features	Material
206-537	Sturdy clamps hold drum centered on base plate in alignment with ram for proper operation. Clamps hold empty drum down while ram is being lifted out.	Grey iron casting

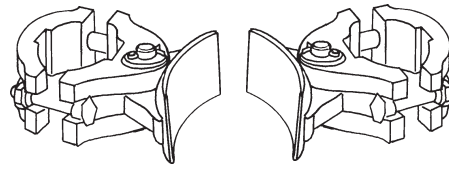

## 55 Gallon (210 Liter) Double Ram Changeover

Part No.	Features
918-468	Pneumatic control automatically switches air supply from one pump to a second pump when supply container empties. Allows uninterrupted supply.

## 55 Gallon (210 Liter) Low Level Cut-Off Alarm

Part No.	Features
511-270	Provides audible alarm to alert operator that drum is empty.

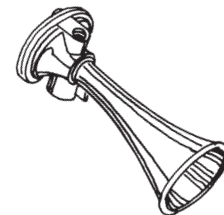

## 55 Gallon (210 Liter) Plate Shields

Part No.	Features	Material
222-792	Ten disposable shields for 55 gallon (210 liter) drums.	Polyethylene



# Stands, Frames, Wheel Kits & Bases

Pump support in a wide variety of sizes to match your installation requirements.

## Bases

Part No.	Graco Pump Support	Features	Material	Inst. Manual
203-622	Fits 5, 10, 16 gallon (19, 38, 61 liters) containers	Four swivel wheels support sturdy platform. Hold-down clamps secure pail to platform.	Painted steel	306-409, 307-100
165-769	Monark, President, Viscount I pumps with 3-tie-rod design and displacement pumps with 1.75 in. (44 mm) diameter	Use only on smooth floor surfaces. Adapts to portable with four casters 101-851 and one set screw 100-672 for pumps. (Order separately.) Includes siphon tube holder.	Cast iron	306-801

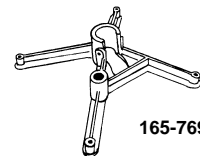
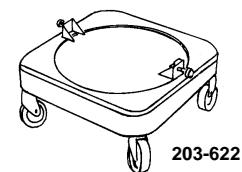

## Stands

Part No.	Graco Pump Support	Features	Material	Inst. Manual
205-640	Pumps with threaded intake with fluid displacement cylinder length less than 22 in. (150 mm)	Sturdy, wide stance pump support. Need adapter 206-108 to fit Monark and President pumps.	Cast iron, steel	306-720
205-700	Pumps with threaded intake and fluid displacement cylinder length of 22 to 33 in. (550 to 840 mm)	Sturdy, wide stance pump support. Need adapter 206-108 to fit Monark and President pumps.	Cast iron, steel	306-720
218-742	High-Flo with high volume and high flow surge tanks	Extra sturdy floor stand.	Painted steel	307-678
220-581	High Flo mid-range with 220-xxx part nos.	Extra sturdy floor stand.	Painted steel	307-837
217-296	Foam-Cat proportioning pump and heater	Sturdy and stable design.	Steel	307-551
222-971	Floor stand for Premier pump	Similar to 217-296 but has Premier wall mount bracket.	Painted steel	308-220

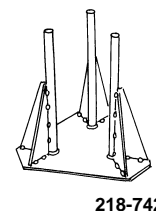
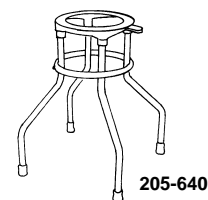

## Wheel Kit

Part No.	Graco Pump Support	Features	Material	Inst. Manual
207-798	Converts 208-211 stand to a portable pump cart	Two 10 in. (250 mm) dia. pneumatic tires and handle with grips.	Steel, rubber wheels	306-988

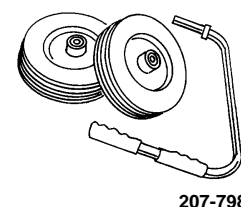

# Pail & Drum Covers

Graco sturdy covers support a wide array of pumps. Choose from pail or drum covers.

## 5 Gallon (19 Liter) Pail Covers

Part No.	Graco Pump Support	Features	Material	Inst. Manual
205-786	Monark 23:1	Agitator mounting port. Secure cover and adjust pump height with thumbscrews 100-220 (3) and spacer 165-094 (1). (Order separately.)	Painted steel	—
164-725	Monark 23:1 and Standard 2:1	Agitator mounting port and fill-port. Secure cover to pail with latch hooks 204-534, latch handles 204-535, pivot pins 161-395, washers 158-223, and cotter pins 100-063. (Order separately.)	Alum.	306-700
206-522	Fire-Ball 15:1	Secure cover and pump to pail with lock washers 100-016, cap screws 100-022, and thumbscrews 100-220 (3). (Order separately.)	Painted steel	—
222-058	Fire-Ball 15:1	Same as 206-522. Includes all fasteners.	Painted steel	—
221-095	Husky 715	Agitator mounting port, suction tube and mounting hardware.	Painted steel	307-857
• 224-302	Standard 2:1	Kit includes SST cover 224-265, pail flange 186-558, screws, plastic 1 in. plug and thumb screw.	SST	308-211

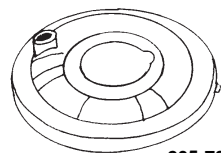

205-786

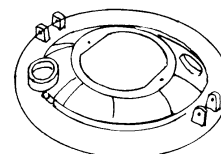

164-725

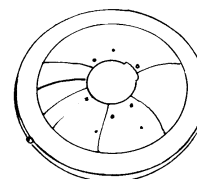

206-522

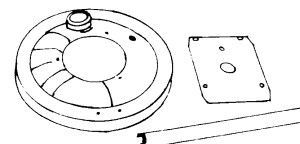

221-095

## 10 Gallon (38 Liter) Pail Covers

Part No.	Graco Pump Support	Features	Material	Instr. Manual
204-574	Fire-Ball 50:1	Thumb screws and rubber gasket.	Painted Steel	306-345



204-574

• **Waterborne compatible**

## 16 Gallon (61 Liter) Drum Covers

Part No.	Graco Pump Support	Features	Material	Inst. Manual
204-574	Fire-Ball 50:1, 15:1, 5:1; Fast-Flo and hand lever pumps	Thumbscrews and cover gasket. Adapter plate 167-754. (Order separately.)	Painted steel	306-345
204-123	Fire-Ball 50:1, 15:1 and Fast-Flo 1:1	Includes rubber gasket. Use with elevator tube 204-121. (Order separately.) Fast-Flo requires adapter plate 167-754. (Order separately.)	Painted steel	306-522
204-269	Fire-Ball 50:1 and 5:1	Hold down rods, brackets and rubber gasket.	Painted steel	306-345

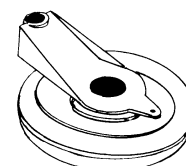

204-123

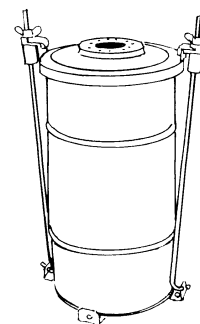

204-269

## 55 Gallon (210 Liter) Drum Covers for Lube Pumps

Part No.	Graco Pump Support	Features	Material	Inst. Manual
200-326	Fire-Ball 45:1, 15:1 and President 10:1	Center mount for open head drums.	Painted steel	—
206-586	Fire-Ball 5:1 and President 10:1	Tie-rod attachment to drum.	Painted steel	306-345
204-273	Fire-Ball 45:1 and 15:1	For in-line pumps.	Painted steel	306-345

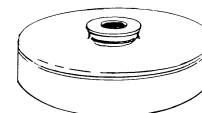

200-326

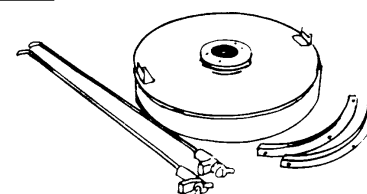

206-586

See also drum cover with agitator 207-199, page 33.

## 55 Gallon (210 Liters) Drum Covers for Paint Pumps & Agitators

Part No.	Graco Pump Support	Features	Material	Inst. Manual
• 237-306	President, Monark, Standard, and Fast-Flo	Includes inspection port plug, bolts, nuts, and gaskets. Fits agitator 206-758 and siphon tube 206-266.	304 SST	308-466
• 237-307	President and Monark	Includes inspection port plug, bolts, nuts, and gaskets. Fits agitators 204-995 and 203-711.	304 SST	308-466
• 237-308	President (two bolt mounting)	Includes inspection port plug, bolts, nuts, and gaskets. Fits agitators 204-955, 206-219 and filter 214-724	304 SST	308-466
• 237-309	King, Bulldog, Senator, and President	Includes inspection port plug, bolts, nuts, and gaskets. Fits agitator 205-715 and air regulator 207-651 (King), and air regulator 205-712 (Bulldog).	304 SST	308-466
• 237-310	Standard	Includes inspection port plug, bolts, nuts, and gaskets. Fits agitators 204-995, 206-219 and filter 214-724.	304 SST	308-466
• 237-949	Glutton	Features inspection port plug, agitator port; return tube ports, Glutton bolt holes and siphon tube port.	304 SST	308-466
• 238-008	Most Graco pumps except Premier	Features only inspection port with plug. No other holes. Additional holes cut to fit particular application.		308-466
• 190-206	Most Graco pumps except Premier	Blank cover with no holes. Heavy duty 12 gauge SST. Not passivated.	304 SST	308-466
• 238-283	Fits agitator 238-157	Includes inspection port, return port and mounting holes for agitator.	304 SST	308-609

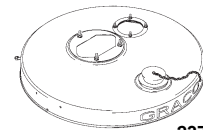

237-306

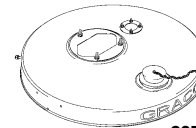

237-307

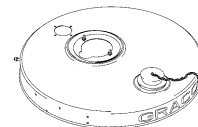

237-308

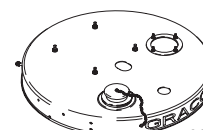

237-949

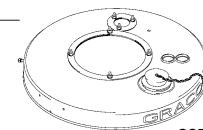

237-309

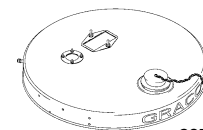

237-310

## Drum Cover Accessories

Part No.	Graco Pump Support	Features
• 237-524	Optional Handle Kit	Includes two SST handles and fasteners.
• 112-924	Drum Lip Gasket	Disposable "snap-fit" gasket provides seal between top of drum and underside of drum cover to minimize evaporation.

**Note:** See elevators and drum cover support accessories on pages 16 & 17. For bung adapter plates see page 26.

### • Waterborne compatible

# Drum Bung Adapter & Flange

Graco adapters allow pumps to be threaded into 2 in. npt bung openings. Supports a wide array of Graco pumps.

## Drum Bung Adapters

Part No.	Graco Pump Support	Features	Material	Inst. Manual
204-076	Mount lightweight lever pumps with 2 $\frac{1}{8}$ in. (54 mm) diameter riser tubes	Use with Sturdi-Clamp 204-095. Includes O-ring seal.	Steel	—
224-579	Same as 204-706 except 224-579 is air tight.	—	Steel	—
205-573	Stainless steel pumps with 2 $\frac{1}{8}$ in. (54 mm) diameter riser tubes	Includes thumbscrew to secure pump riser tube at adjusted height. (Order non-corrosive Sturdi-Clamp 204-858 to mount pump on side of open head drum or tank separately.)	Steel	—
214-583	Carbon steel pumps with 2 in. diameter.	2 in. npt(m) thread. Use with Sturdi-Clamp 204-858 to mount pumps on open head drum or tank. (Order separately.)	Carbon steel	307-331
222-308	Fits Fast-Ball, Eagle, Fire-Ball, President	Includes bolt.	Steel	—
217-359	Fits Fast-Flo 1:1	Air tight, includes O-ring.	Steel	—
• 214-592	Stainless steel pumps with 2 in. diameter	Same as 214-583 except stainless steel.	Stainless steel	—

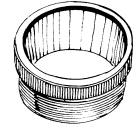

204-076

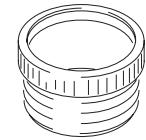

224-579

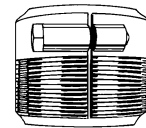

214-583

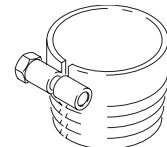

222-308

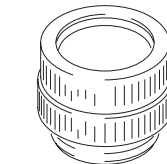

217-359

## Drum Flange

Part No.	Graco Pump Support	Features	Material	Inst. Manual
160-754	Mounting for bung adapter equipped with carbon steel pumps on open head drums when used with drum covers 204-574 or 200-326 (order separately).	2 in. npt(f) opening for bung adapter. Four bolt holes.	Aluminum	306-538
206-258	Use with drum cover 237-306	Three bolt holes	Cast iron	308-466
• 237-571	Use with drum cover 237-306	Three bolt holes	304 SST	308-466

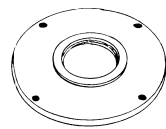

160-754

• Waterborne compatible

# Sturdi-Clamps

Graco clamps hold pumps secure and upright in drum or tanks.

Part No.	Graco Pump Support	Features	Material	Inst. Manual
210-880	Fast-Flo 1:1 pumps	For 2 in. tube, in-line only.	CS	307-427
203-156	Carbon steel pumps with 2 1/8 in. (54 mm) dia. riser tubes. For in-line pumps only.	U-bolt to clamp pump at proper depth.	CS	306-305
204-095	Carbon steel pumps with 2 1/8 in. (54 mm) dia. riser tubes in bung hole of closed head drums when used with Bung Adapter 204-076.	U-bolt to clamp pump at proper depth. In-line pumps only.	CS	306-521
204-858	Stainless steel pumps using SST bung adapter 205-573.	2 in. npt(f) opening for open head drums.	Cast iron, nickel-plated, CS	—

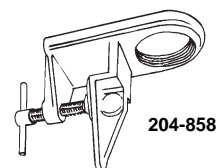
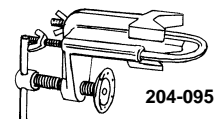
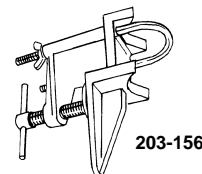
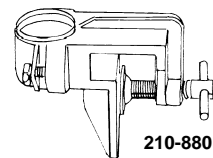

# Grounding Clamp

Part No.	Graco Pump Support	Features	Inst. Manual
222-011	Grounding wire and clamp	7.6 m (25 ft.), 1.5 mm <sup>2</sup> (12 gauge)	—

