



First choice when
quality counts.™

Husky 715 & 1040 Modules for Low Pressure Circulation

PACKAGES

- **Fast, easy installation**
- **Modules packaged and shipped in one crate!**
- **100% designed, manufactured, tested and guaranteed by Graco**
- **Pre-engineered modules allow you to predict the system performance**

**A modular
solution you can
count on to
get the results
you need!**

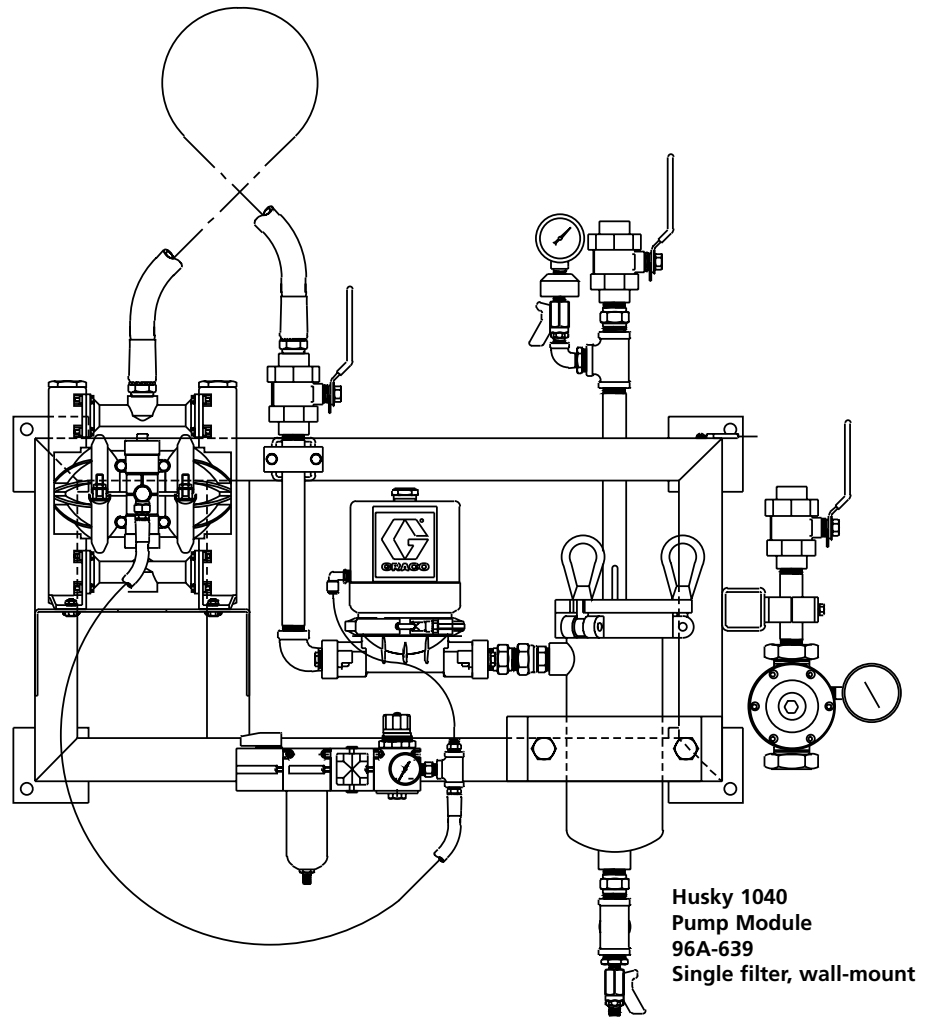

Graco offers these Husky pump modules as versatile, prefabricated diaphragm pump modules for low- to medium-viscosity fluids. The air-operated, stainless steel pumps offer excellent corrosion and abrasion resistance. The modules are pressure and fluid tested for reliable operation so we can provide you with performance-matched components.

Order with one part number, and you will receive one package with full instructions for a quick and easy installation. This module is not only convenient, it is easy to use and maintain.

Technical Specifications

For Husky 715 Modules

Fluid flow at 15 cpm 1.2 gpm (4.5 lpm)
Max. fluid outlet pressure 90 psi (0.6 MPa, 6 bar)
at 15 cpm and 100 psi (0.7 MPa, 7 bar) air inlet pressure
Volume per cycle 0.08 gal. (0.3 liter)

For Husky 1040 Modules

Fluid flow at 25 cpm 4.0 gpm (15 lpm)
Max. fluid outlet pressure 90 psi (0.6 MPa, 6 bar)
at 25 cpm and 100 psi (0.7 MPa, 7 bar) air inlet pressure
Volume per cycle 0.15 gal. (0.6 liter)

Module air inlet 1/4 npt(f)
Module fluid inlet 3/4 npt(f)
Module fluid outlet to supply 3/4 npt(f)
Module fluid return from supply 3/4 npt(f)

Reference Data for Husky Bare Pumps

Instruction Manuals

308-445 Husky 715
308-479 Husky 1040

Data Sheets

305-587 Husky 715
305-588 Husky 1040

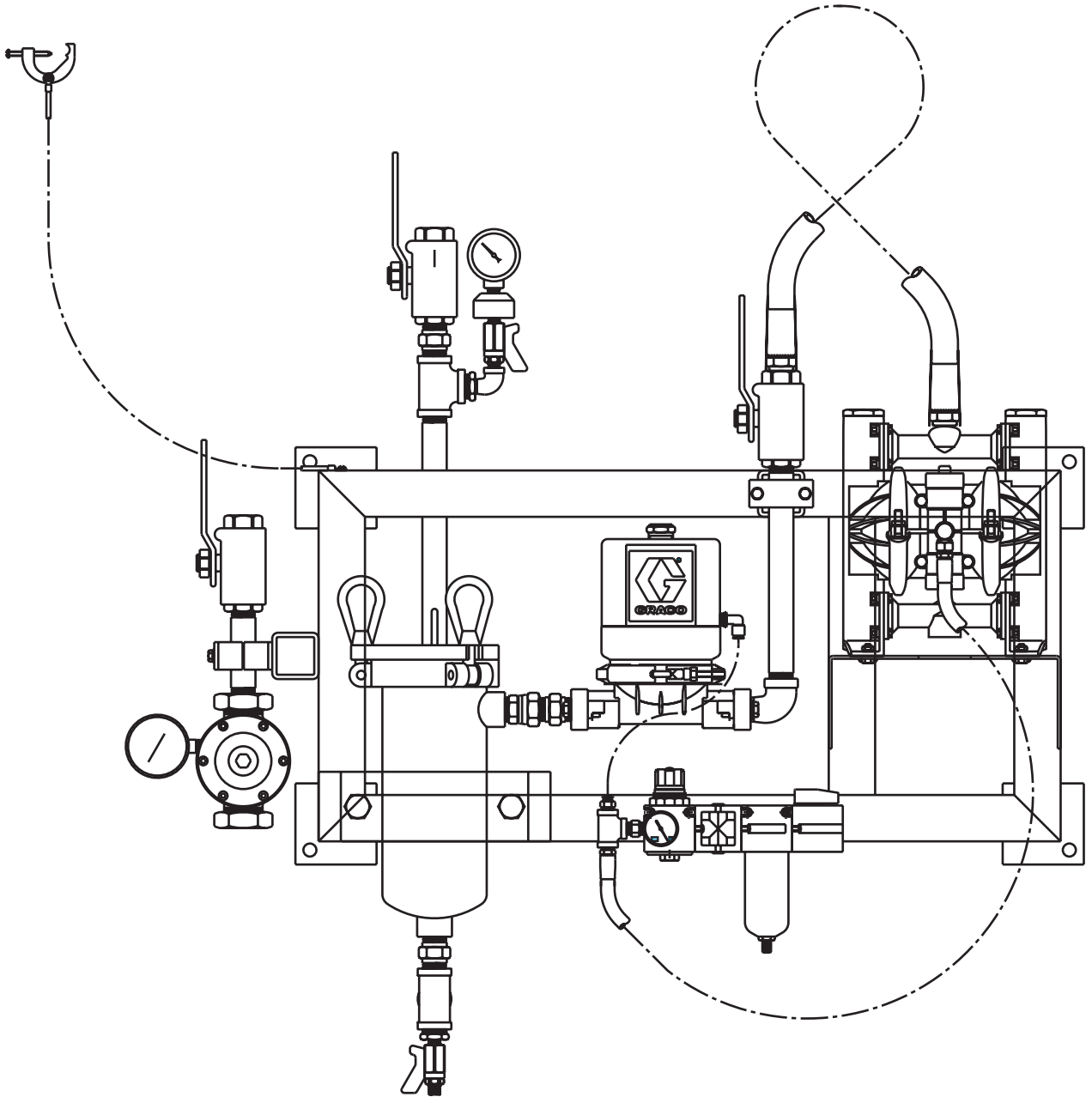

**Husky 715 Pump Module
96A-642
Single filter, wall-mount
(Right Hand)**

Ordering Information

Single Filter Wall-Mount Modules

96A-642 Husky 715 Module, SST (Right Hand)

96A-501 Husky 715 Module, SST (Left Hand)

96A-640 Husky 1040 Module, SST (Right Hand)

96A-639 Husky 1040 Module, SST (Left Hand)

Husky Modules are equipped with:

- Husky 715 or 1040 SST pump
- Model 4 SST bag filter
- Husky SST surge suppressor
- supply and return isolation SST ball valves
- back pressure regulator
- air filter/regulator/lubricator
- heavy-duty, wall-mount frame

Note: Right Hand indicates the pump is on the right side of the module.

Left Hand indicates the pump is on the left side of the module.

Accessories

Floor Stands for Husky Pump Modules

For mounting Husky double diaphragm pump modules off the floor.

For Husky 715

618-090 Single floor stand

618-087 Back-to-back floor stand

For Husky 1040

618-223 Single floor stand

618-224 Single floor stand

917-062 Low Shear Back Pressure Regulator

Minimizes paint degradation and shearing of materials (i.e., mica-filled materials).

Return Line Flow Meter

Visual indication of approximate system flows.

51B-716 For Husky 715 modules

51B-717 For Husky 1040 modules