









AGITATORS

Graco Agitator Selection Guide

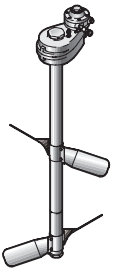
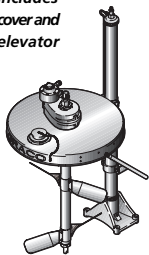
| Tanks | Drums | | Pressure Pots | Pails |
|---|---|---|---|--|
| | OPEN TOP | CLOSED TOP | | |
|  <p>Waterborne & Acid-Catalyst Materials & Other Corrosive Fluids</p> <p>238-157 Heavy-Duty Back-gear Model Use Extension 191-920 or 191-606</p> |  <p>222-698 Fits specific cover (237-306) 962-552 Low shear design 238-157 Heavy-duty back-gear model 962-553 Low shear design, electric 231-414 Heavy-duty, includes siphon, cover and elevator package 231-413 Heavy-duty, non-siphon, includes cover and elevator package 231-418 Heavy-duty back-gear model, includes cover, Husky pump & elevator 231-419 Heavy-duty back-gear model, includes cover, elevator, Husky pump and dispense valve</p> |  <p>236-629 Siphon Twistork™ 236-760 Twistork, oil-less, reversible motor 235-534 Twistork, non-siphon 238-859 Twistork, Husky™(Poly) pump 238-860 Twistork, Husky (Acetal) pump</p> |  <p>236-661 Back-gear model, heavy-duty 5 gallon 236-662 Back-gear model, heavy-duty 10 gallon 236-663 Back-gear model, heavy-duty 15 gallon</p> |  <p>222-695 Single prop, 5 gallon 224-572 Single prop, 10 gallon 210-067 Single prop, 15 gallon</p> |
| <p>Solventborne Materials</p> <p>238-157 Heavy-Duty Back-gear Model Use Extension 191-920 or 191-606</p> <p><i>Note: Waterborne compatible mixers are suitable for use with solventborne materials</i></p>  | <p>238-157 Heavy-duty, back-gear model 225-831 Bracket equipped 207-199 Includes cover 206-758 Fits specific cover (237-306) 204-995 Bracket equipped, fits specific cover (237-307) 203-711 Bracket equipped, fits specific cover (237-307) 206-219 Fits specific cover (237-308) 204-482 Fits specific cover (237-310) 210-068 Sawblade 214-853 Hydraulic 214-906 Hydraulic, includes cover 231-414 Heavy-duty, includes cover and elevator package 231-413 Heavy-duty, non siphon, includes cover and elevator</p>  | <p>224-854 Twistork, non-siphon</p>  | <p>236-661 Back-gear model, heavy-duty 5 gallon 236-662 Back-gear model, heavy-duty 10 gallon 236-663 Back-gear model, heavy-duty 15 gallon</p>  | <p>226-086 Single Prop. 5 gallon 224-572 Single Prop. 15 gallon 207-953 Dual Prop. 15 gallon</p>  |

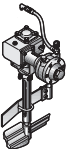
Agitators for Pressure Tanks - Heavy Duty

| Part No. | Description | Drive | HP | Length In. (cm) | Material | Inst. Manual |
|-----------|---------------------------------------|-------|-----|--------------------|----------------|-----------------|
| • 236-661 | 5 gallon (19 liter), gear reduced | Air | 1/2 | 15 (38) | 304/316 SST | 308-371 |
| • 236-662 | 10 gallon (38 liter), gear reduced | Air | 1/2 | 20.75 (53) | 304/316 SST | 308-371 |
| • 236-663 | 15 gallon (57 liter), gear reduced | Air | 1/2 | 31 (79) | 304/316 SST | 308-371 |

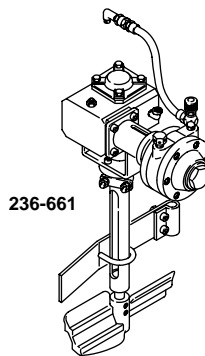

236-661

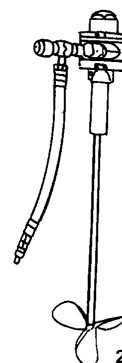

222-695

Agitators for 5 Gallon (19 Liter) Pails

| Part No. | Description | Drive | HP | Length In. (cm) | Material | Inst. Manual |
|-----------|-------------------------|-------|-----|--------------------|----------|-----------------|
| 226-086 | Pail cover, round prop | Air | 1/4 | 13.25 (33.6) | CS | 306-670 |
| • 222-695 | Round prop | Air | 1/4 | 13.25 (33.6) | SST | 307-968 |
| • 204-536 | Round prop (3 blade) | Air | 1/4 | 13.25 (33.6) | SST | 306-565 |

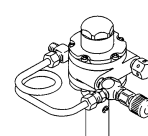
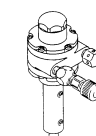

Agitators for 10 Gallon (38 Liter) Pails

| Part No. | Description | Drive | HP | Length In. (cm) | Material | Inst. Manual |
|-----------|--------------------------------|-------|-----|--------------------|----------|-----------------|
| • 224-572 | Single round prop (3 blade) | Air | 1/4 | 17.25 (43.8) | SST | 306-565 |

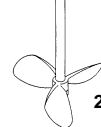

224-572

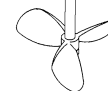

204-536

Agitators for 15 Gallon (57 Liter) Pails

| Part No. | Description | Drive | HP | Length In. (cm) | Material | Inst. Manual |
|-----------|-----------------------------------|-------|-----|--------------------|----------|-----------------|
| 207-953 | Dual round prop (3 blade each) | Air | 1/2 | 29 (73.6) | CS | 306-840 |
| • 210-067 | Sawblade prop | Air | 1/2 | 20.87 (53) | SST | 307-154 |



210-067



207-953

Air Motor

| Part No. | HP | Repair Kit |
|------------------------|-----|------------|
| 101-140 and 162-425 | 0.5 | 207-335 |
| 101-388 | 1 | 207-336 |
| 101-687 | 1/4 | 207-337 |

- Waterborne compatible

Agitators for 55 Gallon (210 Liter) Drum and 30 Gallon (114 Liter) Mix Tanks

| Part No. | Description | Drive | HP | Length In. (cm) | Material | Inst. Manual |
|-----------|--|-------|-------|-----------------|----------------|--------------|
| • 231-414 | Heavy-duty backgeared agitator with elevator, drum cover and siphon kit. | Air | 1/2 | 32 (81.25) | SST | 308-609 |
| • 231-413 | Same as 231-414 except without siphon kit. | Air | 1/2 | 32 (81.25) | SST | 308-609 |
| • 231-418 | Same as 231-414 plus Husky 715, hose and dispense gun. | Air | 1/2 | 32 (81.25) | SST | 308-666 |
| • 231-419 | Same as 231-418 without hose and gun. | Air | 1/2 | 32 (81.25) | SST | 308-666 |
| • 238-157 | Heavy-duty backgeared agitator | Air | 1/2 | 32 (81.25) | SST | 308-609 |
| • 238-250 | Siphon Tube Kit Fits 238-157 agitator | | | 43 (109) | SST | 308-609 |
| • 191-920 | Shaft extension Fits 238-157 agitator Do not use with siphon kit 238-250 | | | 7 (17.8) | SST | 308-609 |
| • 191-606 | Shaft extension Fits 238-157 agitator Do not use with siphon kit 238-250 | | | 16 (40.6) | SST | 308-609 |
| 206-758 | Dual round prop. Mounts on cover. | Air | 1/2 | 31.25 (79.3) | CS | 306-840 |
| 207-199 | Includes 206-758 and 55 gallon (20 liter) cover. | Air | 1/2 | 31.25 (79.3) | CS (SST cover) | 306-938 |
| 203-711 | Mounts on 237-307 SST cover. Agitator supports mount to suction tube or pump cylinder. | Air | 1/2 | 31.25 (79.3) | CS | 306-459 |
| 204-995 | Mounts on 237-307 cover. Mounts to suction tube or pump cylinder. | Air | 1/2 | 31.25 (79.3) | CS | 306-459 |
| 206-219 | Mounts on 237-308 cover. | Air | 1/2 | 31.25 (79.3) | CS (SST cover) | 306-459 |
| 204-482 | Mounts on 237-310 cover. | Air | 1/2 | 31.25 (79.3) | CS | 306-459 |
| 205-715 | For mastics. | Air | 2 1/2 | 33.50 (85) | CS | 306-734 |
| • 210-068 | With sawblade prop. | Air | 1/2 | 33.87 (86) | SST | 307-154 |
| 214-853 | Includes dual round prop. | Hydr. | 1/2 | 34 (86.4) | CS, Alum. | 307-331 |
| 214-906 | Includes cover 237-306. | Hydr. | 1/2 | 34 (86.4) | CS, Alum. | 307-331 |
| • 222-698 | Includes single round prop. | Air | 1/2 | 31.25 (79.3) | SST | 306-840 |
| 225-883 | Includes dual round prop. Open drum. | Air | 2 1/2 | 33.50 (85) | CS, Alum. | 306-426 |
| 225-831 | Includes dual round prop. Open drum. | Air | 1 | 33.50 (85) | CS, Alum. | 306-358 |

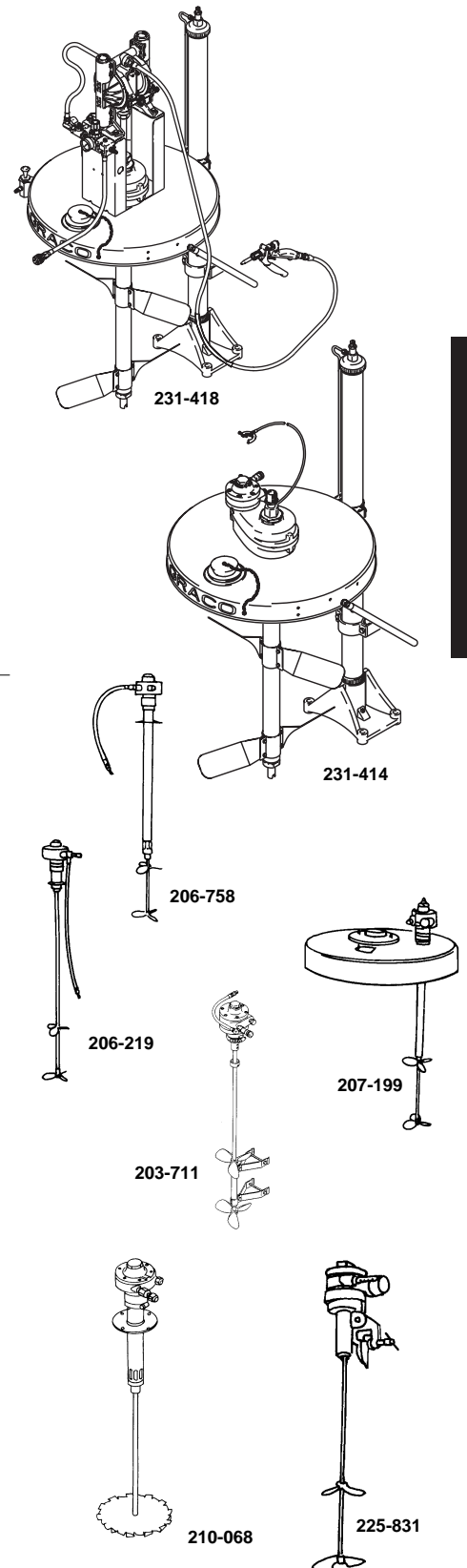

COMPONENTS

• Waterborne compatible

Twistork Agitators

Twistork agitators are the only 2 inch bung-mounted helix mixers available today. They reduce volatile fluid evaporation while maintaining purity of sealed drum contents. Stainless steel models are waterbase compatible. Siphon models provide convenient drum evacuation tube. Large spiral-shaped blade mixes paints, resins, urethanes, and epoxies efficiently. Particularly effective for mixing higher viscosity fluids.

| Part No. | Description | Drive | HP | Length In. (cm) | Material | Inst. Manual |
|-------------|---|-------|----|-----------------|----------|--------------|
| • 236-629 | Twistork, standard siphon model | Air | ¾ | 47.5* (121) | 304 SST | 308-345 |
| • 236-760** | Twistork, siphon model with oilless reversible motor | Air | ¾ | 47.5* (121) | 304 SST | 308-345 |
| • 238-859 | Twistork, siphon with polypropylene/Teflon Husky 715 pump | Air | ¾ | 61 (155) | 304 SST | 308-656 |
| • 238-860 | Twistork, siphon with Acetal/Teflon Husky 715 pump | Air | ¾ | 61 (155) | 304 SST | 308-656 |
| • 224-854 | Twistork, non-siphon | Air | 1½ | 37.25 (95) | CS | 308-175 |
| • 235-534 | Twistork, non-siphon | Air | 1½ | 37.25 (95) | 304 SST | 308-175 |

* Adjustable depth models for drums 31½ in.-35½ in. deep. Siphon tube designed to rest on drum bottom.

** Special order only. Call for delivery. Non-returnable. Replacement oilless reversible motor (112-723) can be ordered separately with muffler (111-881) and adapter for needle valve (159-841) to retrofit standard siphon Twistork 236-629.

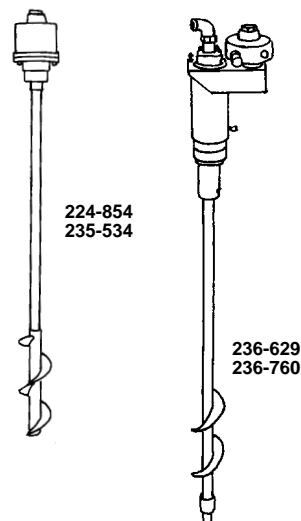

Agitators for 60 Gallon (228 Liter) Mix Tanks

| Part No. | Description | Drive | HP | Length In. (cm) | Material | Inst. Manual |
|----------|-----------------|-------|----|-----------------|-----------|--------------|
| 206-760 | Dual round prop | Air | 1 | 33.25 (84.4) | CS, Alum. | 306-840 |

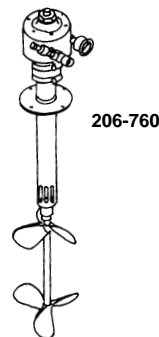

Low Shear Agitators

| Part No. | Description | Drive | Material | Inst. Manual |
|-----------|-----------------------|----------|----------|--------------|
| • 962-552 | LSA 220 drum agitator | Air | SST | 307-904 |
| • 962-553 | LSA 220 drum agitator | Electric | SST | 307-904 |

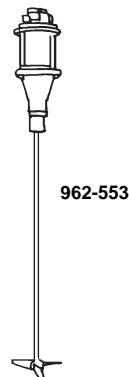

- **Waterborne compatible**